

Lumi United Technology Co., Ltd.

CE TEST REPORT

SCOPE OF WORK:

Article 3.1b of RE directive (2014/53/EU) – EMC report

Model:

HM1S-G01

REPORT NUMBER

200702409SHA-004

ISSUE DATE

August 31, 2020

DOCUMENT CONTROL NUMBER

TTRF55032_V1
© 2018 Intertek



Applicant : Lumi United Technology Co., Ltd.
8th Floor, JinQi Wisdom Valley, No.1 Tangling Road, Liuxian Ave,
Taoyuan Residential District, Nanshan District, Shenzhen. China

Manufacturer : Same as applicant

Manufacturing site : GUANGDONG NEW ENERGY TECHNOLOGY CO., LTD.
Floor1-4, Building 2, No.197 plant, East Side of Xinhua Road,
Tongqiao Town, Zhongkai High-tech Zone, Huizhou, Guangdong,
516032, China

Summary

The equipment complies with the requirements according to the following standard(s) or Specification:

EN 55032: 2015: Electromagnetic compatibility of multimedia equipment - Emission requirements.

EN 55035: 2017: Electromagnetic compatibility of multimedia equipment - Immunity requirements

EN IEC 61000-3-2:2019: Electromagnetic compatibility (EMC) - Part 3-2: Limits - Limits for harmonic current emissions (equipment input current $\leq 16A$ per phase)

EN 61000-3-3:2013+A1:2019: Electromagnetic compatibility (EMC) - Part 3-3: Limits – Limitation of voltage changes, voltage fluctuations and flicker in public low-voltage supply systems, for equipment with rated current $\leq 16 A$ per phase and not subject to conditional connection (IEC 61000-3-3:2013+A1:2017)

PREPARED BY:

REVIEWED BY:



Project Engineer
Eric Li

Reviewer
Wakeyou Wang

Contents

REVISION HISTORY	7
MEASUREMENT RESULT SUMMARY	8
1 GENERAL INFORMATION	9
1.1 DESCRIPTION OF EQUIPMENT UNDER TEST (EUT)	9
1.2 DESCRIPTION OF TEST FACILITY	10
2 TEST SPECIFICATIONS	11
2.1 NORMATIVE REFERENCES	11
2.2 MODE OF OPERATION DURING THE TEST.....	12
2.3 TEST PERIPHERALS USED	12
2.4 RECORD OF CLIMATIC CONDITIONS	12
2.5 INSTRUMENT LIST	13
2.6 MEASUREMENT UNCERTAINTY	15
3 CONDUCTED DISTURBANCE VOLTAGE AT MAINS TERMINALS	16
3.1 LIMITS.....	16
3.1.1 <i>Limits for class A equipment</i>	16
3.1.2 <i>Limits for class B equipment</i>	16
3.2 TEST SETUP	17
3.3 TEST PROCEDURE.....	18
3.4 TEST RESULT.....	19
4 CONDUCTED DISTURBANCE FOR ASYMMETRIC MODE	23
4.1 LIMITS.....	23
4.1.1 <i>Limits for class A equipment</i>	23
4.1.2 <i>Limits for class B equipment</i>	23
4.2 TEST SETUP	24
4.3 TEST PROCEDURE.....	26
4.4 TEST RESULT.....	27
5 CONDUCTED DIFFERENTIAL VOLTAGE EMISSION	28
5.1 LIMITS.....	28
5.2 TEST SETUP	28
5.3 TEST PROCEDURE.....	29
5.4 TEST RESULT.....	30
6 RADIATED EMISSION	31
6.1 LIMITS.....	31
6.1.1 <i>Limits for radiated disturbance of class A Equipment</i>	31
6.1.2 <i>Limits for radiated disturbance of class B Equipment</i>	31
6.2 BLOCK DIAGRAM OF TEST SET UP	32
6.3 TEST PROCEDURE.....	33
6.4 TEST RESULT.....	34
7 HARMONIC CURRENT EMISSION	42
7.1 TEST SETUP.....	42
7.2 TEST PROCEDURE.....	42
7.3 TEST RESULT.....	42

TEST REPORT

8	VOLTAGE FLUCTUATIONS AND FLICKER	43
8.1	TEST SETUP.....	43
8.2	TEST PROCEDURE.....	43
8.2.1	<i>Definition</i>	43
8.2.2	<i>Test Procedure</i>	43
8.3	TEST RESULT.....	43
	IMMUNITY TEST	44
9	ELECTROSTATIC DISCHARGES (ESD).....	45
9.1	SEVERITY LEVEL AND PERFORMANCE CRITERION.....	45
9.1.1	<i>Test level</i>	45
9.1.2	<i>Performance Criterion</i>	45
9.2	TEST SETUP.....	46
9.3	TEST PROCEDURE.....	47
9.4	TEST RESULT.....	48
10	CONTINUOUS RF DISTURBANCES	49
10.1	SEVERITY LEVEL AND PERFORMANCE CRITERION	49
10.1.1	<i>Test level</i>	49
10.1.2	<i>Performance Criterion</i>	49
10.2	TEST SETUP	50
10.3	TEST PROCEDURE	51
10.4	TEST RESULT.....	52
11	CONTINUOUS INDUCED RF DISTURBANCES	53
11.1	SEVERITY LEVEL AND PERFORMANCE CRITERION	53
11.1.1	<i>Test level</i>	53
11.1.2	<i>Performance Criterion</i>	53
11.2	BLOCK DIAGRAM OF TEST SETUP	54
11.3	TEST PROCEDURE	54
11.4	TEST RESULT.....	55
12	POWER FREQUENCY MAGNETIC FIELD.....	56
12.1	SEVERITY LEVEL AND PERFORMANCE CRITERION	56
12.1.1	<i>Test level</i>	56
12.1.2	<i>Performance Criterion</i>	56
12.2	TEST SETUP	57
12.3	TEST PROCEDURE	57
12.4	TEST RESULT.....	58
13	ELECTRICAL FAST TRANSIENTS/BURST	59
13.1	SEVERITY LEVEL AND PERFORMANCE CRITERION	59
13.1.1	<i>Test level</i>	59
13.1.2	<i>Performance Criterion</i>	59
13.2	TEST SETUP	60
13.3	TEST PROCEDURE	60
13.4	TEST RESULT.....	61
14	SURGES.....	62
14.1	SEVERITY LEVEL AND PERFORMANCE CRITERION	62
14.1.1	<i>Test level</i>	62
14.1.2	<i>Performance Criterion</i>	62
14.2	TEST SETUP	63
14.3	TEST PROCEDURE	63

TEST REPORT

- 14.4 TEST RESULT 64
- 15 VOLTAGE DIPS AND INTERRUPTIONS 65**
 - 15.1 SEVERITY LEVEL AND PERFORMANCE CRITERION 65
 - 15.1.1 *Test level and performance criterion* 65
 - 15.2 TEST SETUP 66
 - 15.3 TEST PROCEDURE 66
 - 15.4 TEST RESULT 67
- 16 BROADBAND IMPULSIVE CONDUCTED DISTURBANCES 68**
 - 16.1 SEVERITY LEVEL AND PERFORMANCE CRITERION 68
 - 16.1.1 *Test level* 68
 - 16.1.2 *Performance Criterion* 68
 - 16.2 TEST SETUP 69
 - 16.3 TEST PROCEDURE 69
 - 16.4 TEST RESULT 70
- APPENDIX I: PHOTOGRAPH OF EQUIPMENT UNDER TEST 71**

Revision History

Report No.	Version	Description	Issued Date
200702409SHA-004	Rev. 01	Initial issue of report	August 31, 2020

Measurement result summary

TEST ITEM	TEST RESULT	NOTE
Conducted disturbance voltage at mains terminals	Pass	
Conducted disturbance for asymmetric mode	NA	There's no cable longer than 3 m
Conducted differential voltage emission	NA	The product is not Class B broadcasting receiver
Radiation emission	Pass	
Harmonic current emission	Pass	
Voltage fluctuations and flicker	Pass	
Electrostatic discharges	Pass	
Continuous RF disturbances	Pass	
Continuous induced RF disturbances	Pass	There's no cable longer than 3 m
Power frequency magnetic field	NA	The product does not contain devices susceptible to magnetic fields.
Electrical fast transients/burst	Pass	There's no cable longer than 3 m
Surges	Pass	There's no cable longer than 3 m
Voltage dips and interruptions	Pass	
Broadband impulsive conducted disturbances	NA	There's no xDSL ports

Notes: 1: NA =Not Applicable

2: Determination of the test conclusion is based on IEC Guide 115 in consideration of measurement uncertainty.

3: Additions, Deviations and Exclusions from Standards: None.

1 GENERAL INFORMATION

1.1 Description of Equipment Under Test (EUT)

Product name : Hub M1S

Type/Model : HM1S-G01

Description of EUT : EUT is a Hub, it supports zigbee and wifi functions. There is one model,
We test it and list the worst data in this report.

Rating : 100-240V AC 50/60Hz 0.2A

EUT type : Table-top
 Floor standing

Port identification : Main power

Cable supplied : Refer to the user's manual

Sample received date : July 11, 2020

Date of test : July 11~July 28, 2020

1.2 Description of Test Facility

Name : Intertek Testing Services Shanghai

Address : Building 86, No. 1198 Qinzhou Road(North), Shanghai 200233, P.R. China

Telephone : 86 21 61278200

Telefax : 86 21 54262353

The test facility is recognized, certified, or accredited by these organizations :

- CNAS Accreditation Lab
Registration No. CNAS L0139
- FCC Accredited Lab
Designation Number: CN1175

- IC Registration Lab
CAB identifier.: CN0051

- VCCI Registration Lab
Registration No.: R-14243, G-10845, C-14723, T-12252

- A2LA Accreditation Lab
Certificate Number: 3309.02

Subcontractor:**Name**

Waltek Services Testing Group Limited

Address

2/F,2nd Building, Sunlink International Machinery City, Chencun Town, Shunde District, Foshan 528313, Guangdong, China

Telephone

+86-757-23811398

CNAS No

L3110

2 TEST SPECIFICATIONS

2.1 Normative references

EN 55032: 2015: "Electromagnetic compatibility of multimedia equipment - Emission requirements".

EN 55035: 2017: "Electromagnetic compatibility of multimedia equipment - Immunity requirements".

EN 61000-3-2:2019: Electromagnetic compatibility (EMC) - Part 3-2: Limits - Limits for harmonic current emissions (equipment input current $\leq 16\text{A}$ per phase)

EN 61000-3-3:2013+A1:2019: Electromagnetic compatibility (EMC) - Part 3-3: Limits – Limitation of voltage changes, voltage fluctuations and flicker in public low-voltage supply systems, for equipment with rated current $\leq 16\text{ A}$ per phase and not subject to conditional connection (IEC 61000-3-3:2013+A1:2017)

2.2 Mode of operation during the test

Within this test report, EUT was tested under all available operation modes and tested under its rating voltage and frequency. Other voltage and frequency are specified if used.

2.3 Test peripherals used

Item No	Description	Band and Model	S/No
1	/	/	/

2.4 Record of climatic conditions

Test Item	Temperature (°C)	Relative Humidity (%)	Pressure (Kpa)
Conducted disturbance voltage at mains terminals	24	53	NA
Conducted disturbance for asymmetric mode	NA	NA	NA
Conducted differential voltage emission	NA	NA	NA
Radiation emission	25	51	NA
Harmonic current emission	NA	NA	NA
Voltage fluctuations and flicker	NA	NA	NA
Electrostatic discharges	25	54	101
Continuous RF disturbances	25	54	NA
Continuous induced RF disturbances	25	54	NA
Power frequency magnetic field	NA	NA	NA
Electrical fast transients/burst	24	52	NA
Surges	24	52	NA
Voltage dips and interruptions	24	52	NA
Broadband impulsive conducted disturbances	NA	NA	NA

Notes: NA =Not Applicable

2.5 Instrument list

Conducted Emission						
Item	Equipment	Manufacturer	Model No.	Serial No.	Last Calibration Date	Valid
1	EMI Test Receiver	R&S	ESCI	100947	2019-09-17	2020-09-16
2	LISN	R&S	ENV216	100115	2019-09-17	2020-09-16
3	Cable	Top	TYPE16(3.5M)	-	2019-09-17	2020-09-16
3m Semi-anechoic Chamber for Radiation						
Item	Equipment	Manufacturer	Model No.	Serial No.	Last Calibration Date	Valid
1	Spectrum Analyzer	R&S	FSP30	100091	2020-04-20	2021-04-19
2	Broad-band Horn Antenna	SCHWARZBECK	BBHA 9120 D	667	2020-04-25	2021-04-24
3	Broadband Preamplifier	COMPLIANCE DIRECTION	PAP-1G18	2004	2020-04-20	2021-04-19
4	Coaxial Cable (above 1GHz)	ZT26-NJ-NJ-8M/FA	1GHz-18GHz	NA	2020-04-20	2021-04-19
5	Test Receiver	R&S	ESCI	101296	2020-04-20	2021-04-19
6	Trilog Broadband Antenna	SCHWARZBECK	VULB9160	9160-3325	2020-04-25	2021-04-24
7	Amplifier	ANRITSU	MH648A	M43381	2020-04-20	2021-04-19
8	Cable	HUBER+SUHNER	CBL2	525178	2020-04-20	2021-04-19
Flicker Measuring System						
Item	Equipment	Manufacturer	Model No.	Serial No.	Last Calibration Date	Valid
1	Digital Power Analyzer	SCHAFFNER	CCN 1000-1	72625	2020-04-20	2021-04-19
2	Power Source	SCHAFFNER	NSG 1007	58477	2020-04-20	2021-04-19
Electrostatic Discharge						
Item	Equipment	Manufacturer	Model No.	Serial No.	Last Calibration Date	Valid
1	Electrostatic Discharge Simulator	SCHLODER	SESD 216	606144	2020-04-24	2021-04-23
Radio-frequency electromagnetic fields						
Item	Equipment	Manufacturer	Model No.	Serial No.	Last Calibration Date	Valid
1	Signal Generator	R&S	SMB100A	105942	2019-09-17	2020-09-16
2	RF Power Amplifier	BONN Elektronik	BLWA0830-160/100/40D	128740	2019-09-17	2020-09-16
3	Gestockte Breitband (S tacked) Log.-per.Antenna	SCHWARZBECK	STLP9128D	043	2019-09-17	2020-09-16
4	Power Meter	R&S	NRP2	102031	2020-04-20	2021-04-19
5	Amplifier	NJNT	NTWPAS-	2560025	2020-04-20	2021-04-19

			2560025			
6	Broad-band Horn Antenna	SCHWARZBECK	BBHA 9120 D	667	2020-04-28	2021-04-27
Surge, EFT, Voltage dips and Interruption						
Item	Equipment	Manufacturer	Model No.	Serial No.	Last Calibration Date	Valid
1	All Modules Generator	SCHAFFNER	6150	34579	2019-09-17	2020-9-16
2	Capacitive Coupling Clamp	SCHAFFNER	CDN 8014	25311	2019-09-17	2020-9-16
3	Signal and Data Line Coupling Network	SCHAFFNER	CDN 117	25627	2019-09-17	2020-9-16
4	AC Power Supply	HENGYUAN	DTDGC-4	-	2019-09-17	2020-9-16
Conducted Immunity						
Item	Equipment	Manufacturer	Model No.	Serial No.	Last Calibration Date	Valid
1	RF Generator	TESEQ	NSG4070	25781	2019-09-17	2020-9-16
2	CDN M-Type	TESEQ	CDN M016	25112	2019-09-17	2020-9-16
3	EM-Clamp	TESEQ	KEMZ 801	25453	2019-09-17	2020-9-16
4	Attenuator 6dB	TESEQ	ATN6050	25376	2019-09-17	2020-9-16
RF Test						
Item	Equipment	Manufacturer	Model No.	Serial No.	Last Calibration Date	Valid
1	EXA Signal Analyzer	Malaysia Keysight	N9010A	MY50520207	2020-04-20	2021-04-19
2	ESG VECTOR SIGNAL GENERATOR	Malaysia Keysight	E4438C	MY45092536	2020-04-20	2021-04-19
3	EXG Analog Signal Generator	Malaysia Keysight	N5171B	MY53050845	2019-09-17	2020-09-16
4	Signal Generator	Agilent	N5182A	MY46240814	2019-09-17	2020-09-16
5	USB Wideband Power Sensor	Malaysia Keysight	U2021XA	SG54400003	2019-09-17	2020-09-16
6	Universal Radio Communication Tester	R&S	CMW500	116543	2019-09-17	2020-09-16

2.6 Measurement Uncertainty

Measurement	Frequency	Expanded Uncertainty (k=2) (±)
Conducted disturbance voltage at mains terminals	9kHz ~ 150kHz	3.71 dB
	150kHz ~ 30MHz	3.31 dB
Conducted disturbance measurements using a VP	150kHz ~ 30MHz	2.75 dB
Continuous disturbance voltage at telecom port with AAN	150kHz ~ 30MHz	4.10 dB
Continuous disturbance current at telecom port	150kHz ~ 30MHz	2.73 dB
Radiated Emissions up to 1 GHz	30MHz ~ 1GHz	5.04 dB
Radiated Emissions above 1 GHz	1GHz ~ 6GHz	4.97 dB
	6GHz ~ 18GHz	5.29 dB
Harmonic current	0-2000Hz /0-40 orders	3.90%
Voltage fluctuation and flicker	/	10.34%
ESD (Discharge Voltage)	/	6.65%
EFT (Test Voltage at mains terminal)	/	11.57%
EFT (Test Voltage at signal/Telecom line)	/	11.62%
Surge (Test Voltage at mains terminal)	/	11.57%
Surge (Test Voltage at signal/Telecom line)	/	11.89%
Injected current at mains terminal	/	1.88 dB
Injected current at unshielded signal ports	/	3.41 dB
Injected current at shielded signal ports	/	3.30 dB
Radiated susceptibility test (80-1000MHz)	/	2.38 dB
Voltage dips and interruption (Test Voltage)	/	6.05%

3 Conducted disturbance voltage at mains terminals

Test result: Pass

3.1 Limits

3.1.1 Limits for class A equipment

Frequency range (MHz)	Quasi-peak (dBuV)	Average (dBuV)
0.15 ~ 0.5	79	66
0.5 ~ 30	73	60

Note: 1. Coupling device is AMN;
 2. Detector type is Quasi Peak or Average
 3. Bandwidth is 9 kHz

3.1.2 Limits for class B equipment

Frequency range (MHz)	Quasi-peak (dBuV)	Average (dBuV)
0.15 ~ 0.5	66 ~ 56 *	56 ~ 46 *
0.5 ~ 5	56	46
5 ~ 30	60	50

Note: 1. * Means the limit decreasing linearly with the logarithm of the frequency in the range 0.15MHz to 0.5MHz
 2. Coupling device is AMN;
 3. Detector type is Quasi Peak or Average
 4. Bandwidth is 9 kHz

3.2 Test setup

For table-top equipment

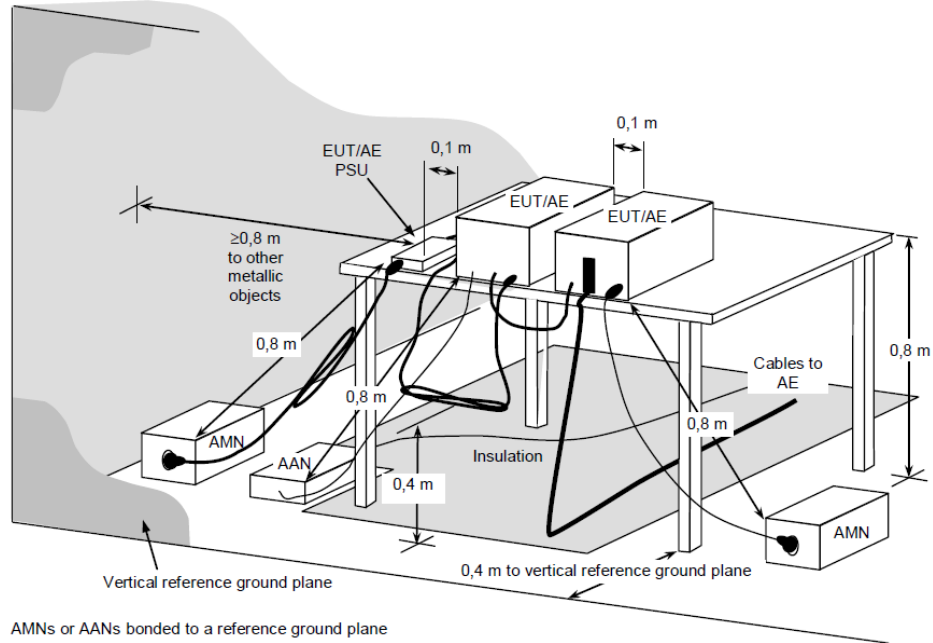

For floor standing equipment

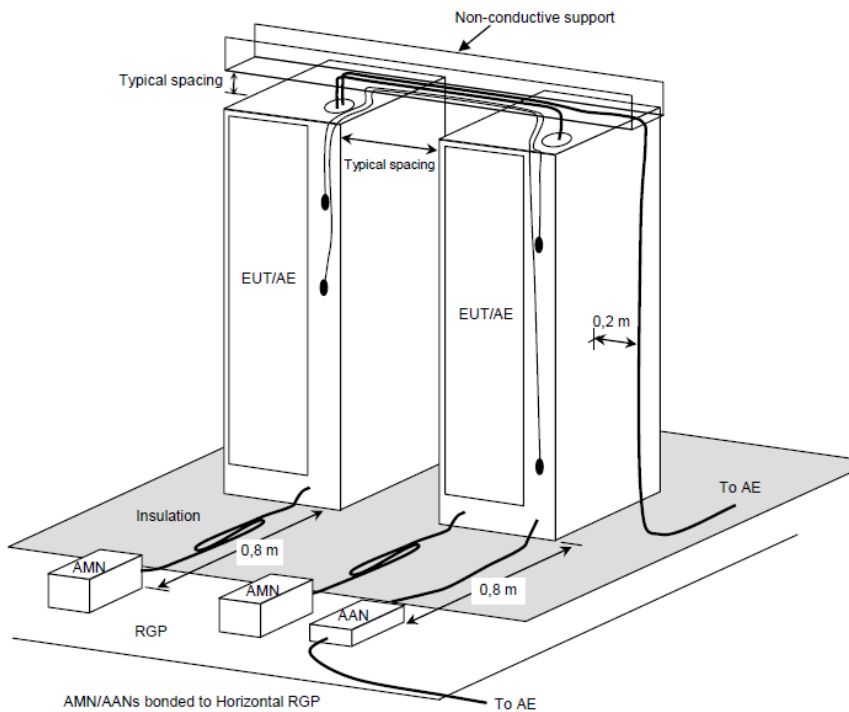

3.3 Test Procedure

Measurement was performed in shielded room, and instruments used were followed CISPR 16-2-1 clause 7.

Detailed test procedure was following clause 7 of CISPR 16-2-1.

Frequency range 150kHz – 30MHz was checked and EMI receiver measurement bandwidth was set to 9 kHz.

3.4 Test Result of 230VAC

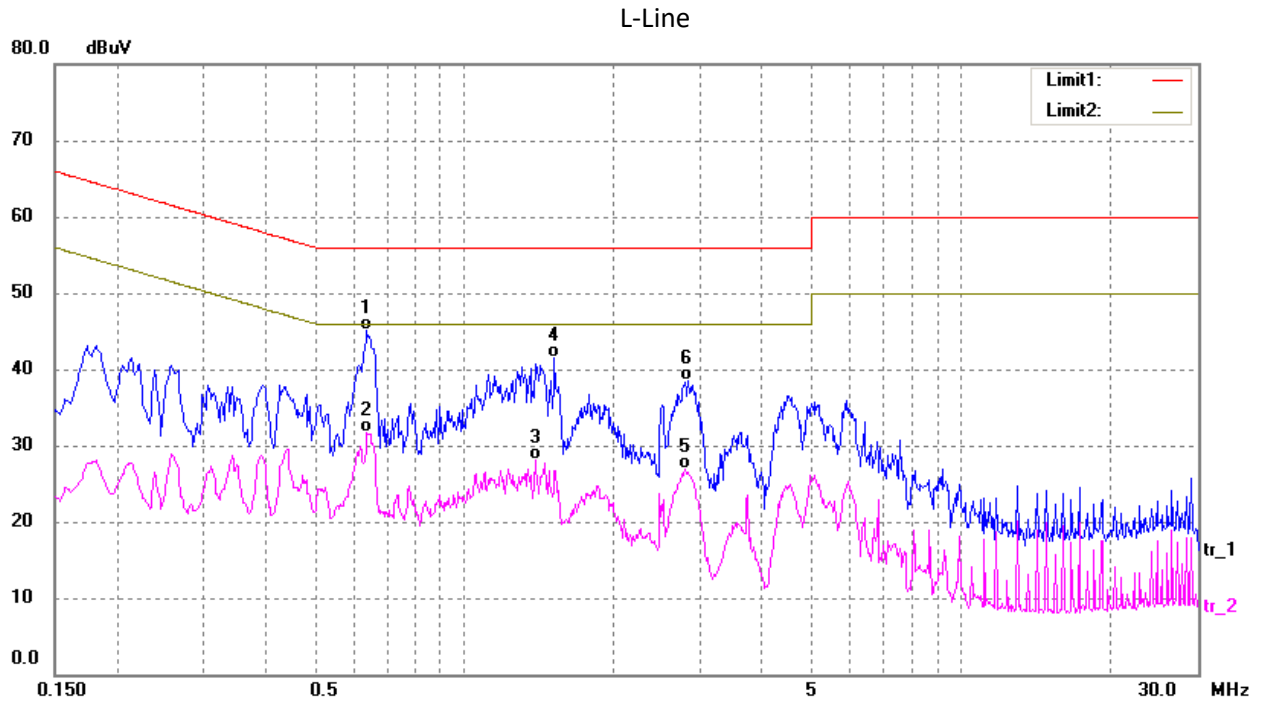

Test Data:

No.	Frequency (MHz)	Reading (dBuV)	Correct (dB/m)	Result (dBuV)	Limit (dBuV)	Margin (dB)	Detector
1*	0.6380	35.08	10.05	45.13	56.00	-10.87	QP
2	0.6380	21.70	10.05	31.75	46.00	-14.25	AVG
3	1.3940	17.82	10.37	28.19	46.00	-17.81	AVG
4	1.5260	31.11	10.37	41.48	56.00	-14.52	QP
5	2.7820	16.55	10.39	26.94	46.00	-19.06	AVG
6	2.8260	28.12	10.39	38.51	56.00	-17.49	QP

N-Line

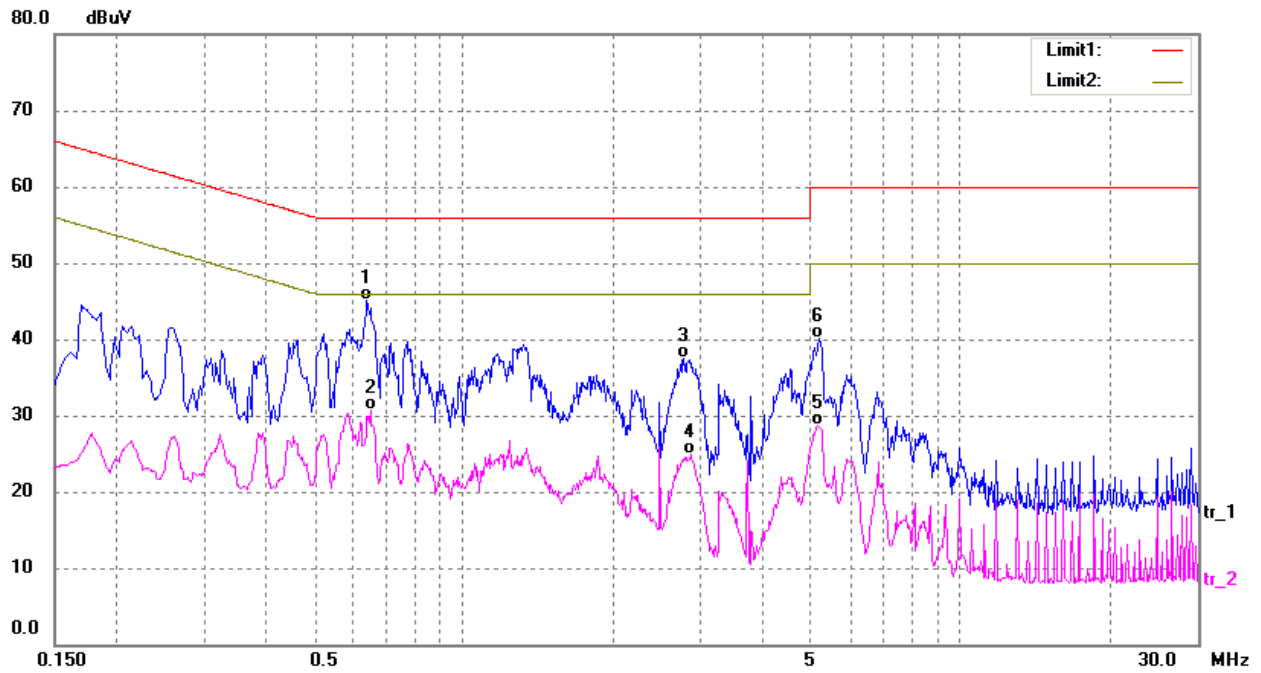

Test Data:

No.	Frequency (MHz)	Reading (dBuV)	Correct (dB/m)	Result (dBuV)	Limit (dBuV)	Margin (dB)	Detector
1*	0.6380	35.00	10.05	45.05	56.00	-10.95	QP
2	0.6500	20.59	10.04	30.63	46.00	-15.37	AVG
3	2.7780	27.10	10.39	37.49	56.00	-18.51	QP
4	2.8580	14.51	10.39	24.90	46.00	-21.10	AVG
5	5.1500	18.24	10.39	28.63	50.00	-21.37	AVG
6	5.1700	29.78	10.39	40.17	60.00	-19.83	QP

Test Curve of 120VAC:

L Line

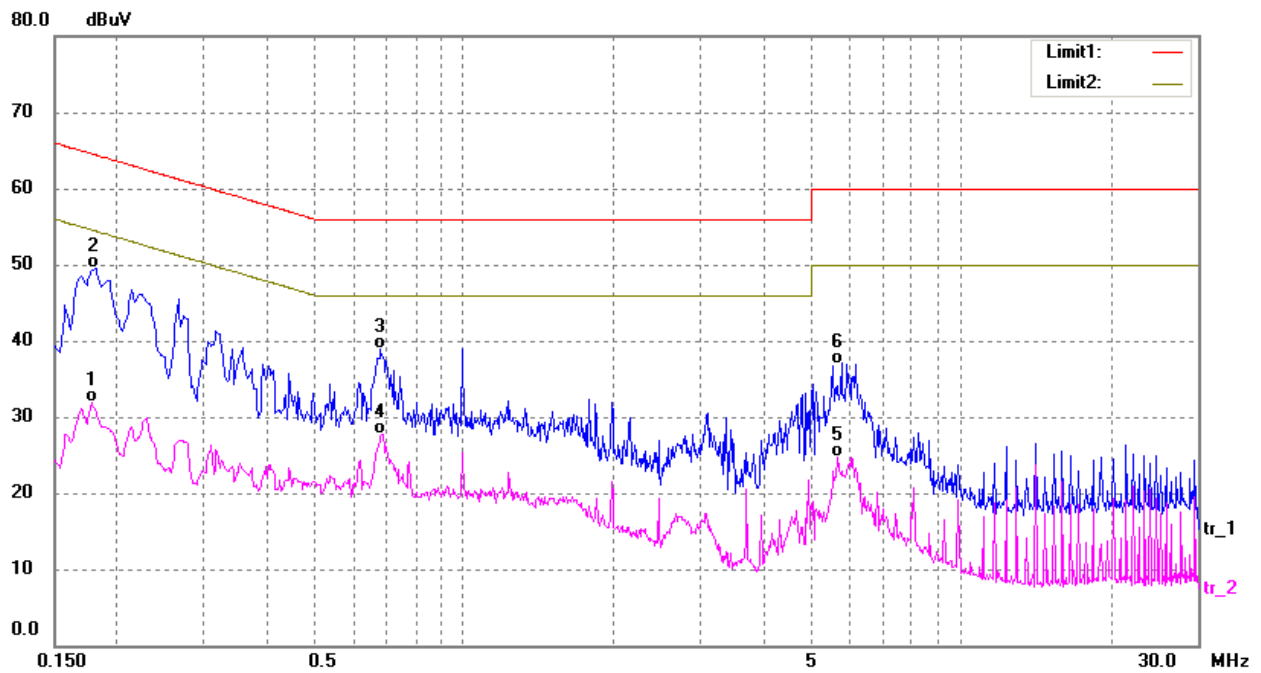

No.	Frequency (MHz)	Reading (dBuV)	Correct (dB/m)	Result (dBuV)	Limit (dBuV)	Margin (dB)	Detector
1	0.1780	21.64	10.26	31.90	54.57	-22.67	AVG
2*	0.1819	39.19	10.26	49.45	64.39	-14.94	QP
3	0.6820	28.73	10.17	38.90	56.00	-17.10	QP
4	0.6860	17.56	10.17	27.73	46.00	-18.27	AVG
5	5.6539	14.53	10.23	24.76	50.00	-25.24	AVG
6	5.7499	26.77	10.23	37.00	60.00	-23.00	QP

N Line

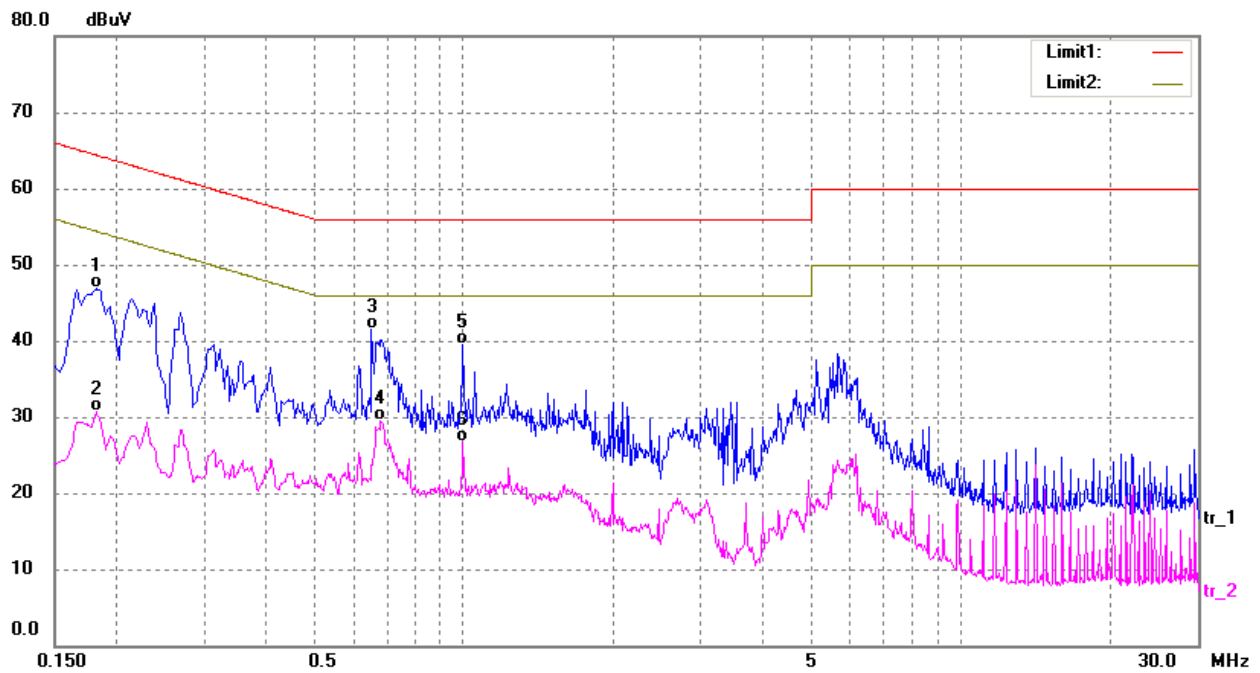

No.	Frequency (MHz)	Reading (dBuV)	Correct (dB/m)	Result (dBuV)	Limit (dBuV)	Margin (dB)	Detector
1	0.1819	36.61	10.26	46.87	64.39	-17.52	QP
2	0.1819	20.49	10.26	30.75	54.39	-23.64	AVG
3*	0.6540	31.23	10.19	41.42	56.00	-14.58	QP
4	0.6820	19.37	10.17	29.54	46.00	-16.46	AVG
5	0.9980	29.24	10.20	39.44	56.00	-16.56	QP
6	0.9980	16.41	10.20	26.61	46.00	-19.39	AVG

Remark: 1. Correct Factor = LISN Factor + Cable Loss, the value was added to Original Receiver Reading by the software automatically.

2. Corrected Reading = Original Receiver Reading + Correct Factor

3. Margin = Limit - Corrected Reading

4. If the PK Corrected Reading is lower than AV limit, the AV test can be elided.

Example: Assuming LISN Factor = 10.00dB, Cable Loss = 2.00dB,
 Original Receiver Reading = 10.00dBuV, Limit = 66.00dBuV.
 Then Correct Factor = 10.00 + 2.00 = 12.00dB;
 Corrected Reading = 10dBuV + 12.00dB = 22.00dBuV;
 Margin = 66.00dBuV – 22.00dBuV = 44.00dB.

4 Conducted disturbance for asymmetric mode

Test result: NA

4.1 Limits

4.1.1 Limits for class A equipment

Frequency range (MHz)	Voltage Limits dB(μ V)		Current limits dB(μ A)	
	Quasi-peak	Average	Quasi-peak	Average
0.15 ~ 0.5	97 ~ 87	84 ~ 74	53 ~ 43	40 ~ 30
0.5 ~ 30	87	74	43	30
Note: if "150 Ω to 50 Ω adaptor" applied, correction factor of 9.5dB should be added to the test data.				

4.1.2 Limits for class B equipment

Frequency range (MHz)	Voltage Limits dB(μ V)		Current limits dB(μ A)	
	Quasi-peak	Average	Quasi-peak	Average
0.15 ~ 0.5	84 ~ 74	74 ~ 64	40 ~ 30	30 ~ 20
0.5 ~ 30	74	64	30	20
Note: if "150 Ω to 50 Ω adaptor" applied, correction factor of 9.5dB should be added to the test data.				

4.2 Test setup

Coupling device: CVP and Current probe (alternative method 1)

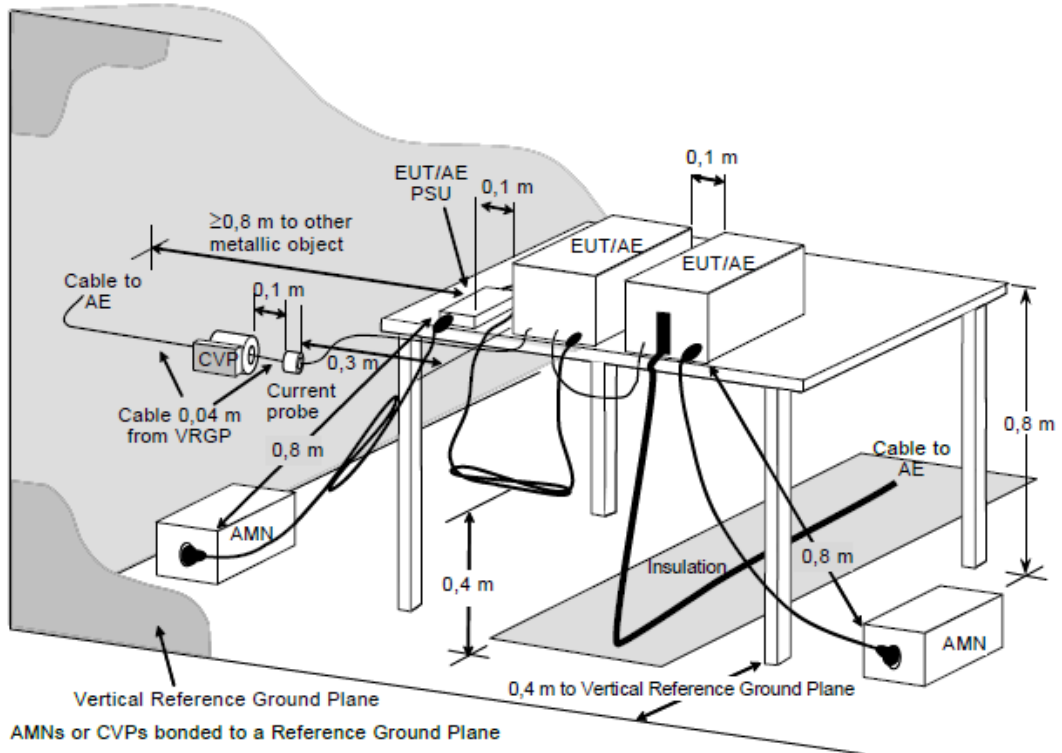

Coupling device: CVP and Current probe (alternative method 2)

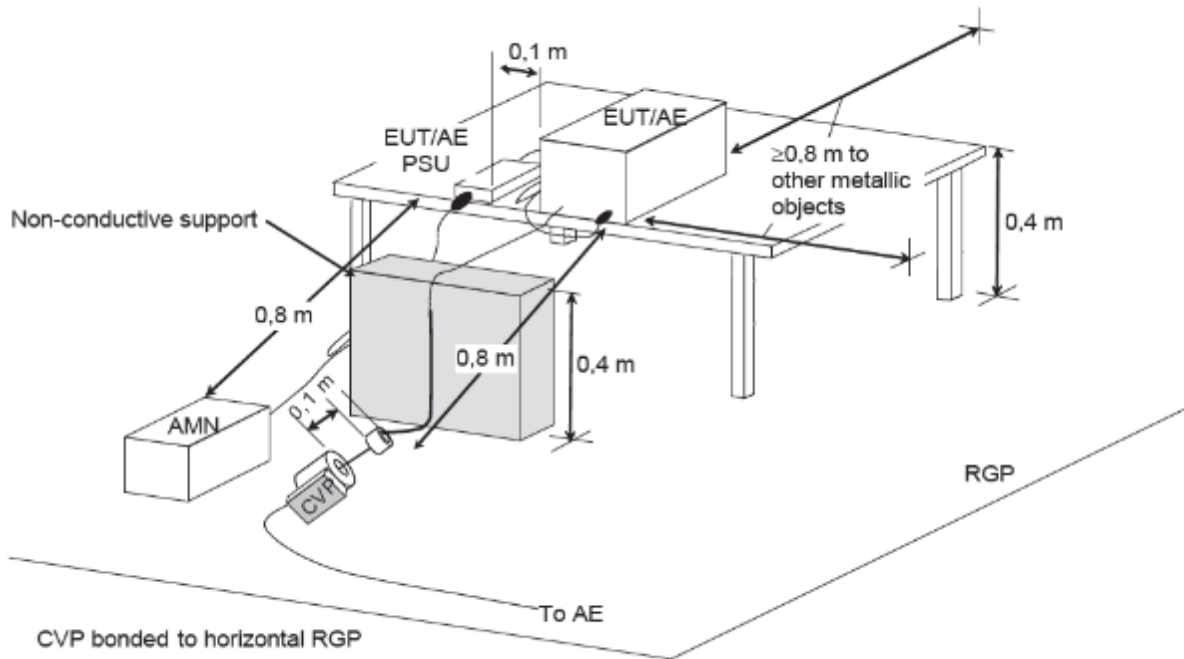

Coupling device: AAN

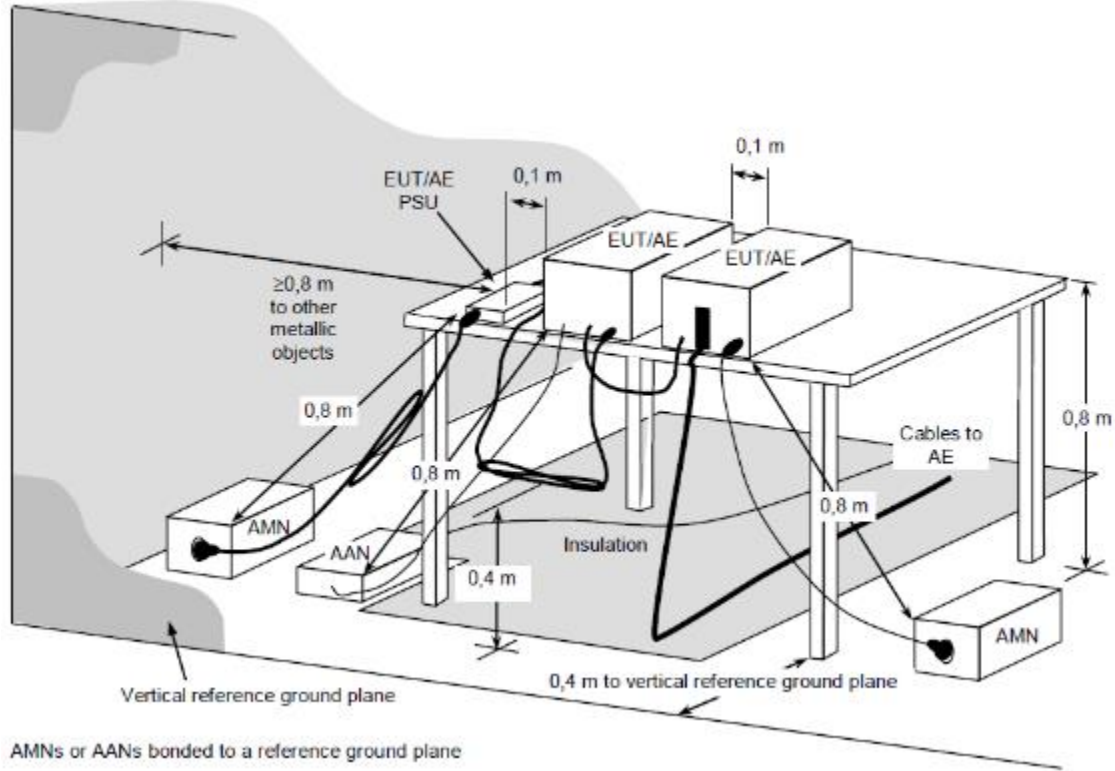

4.3 Test Procedure

Measurement was performed in shielded room, and instruments used were followed EN 55032 clause C.4.1.

Detailed test procedure was following clause C.4.1 of EN 55032.

Frequency range 150kHz – 30MHz was checked and EMI receiver measurement bandwidth was set to 9 kHz.

Used	Data Port	Measurement type	Coupling device	No. of Pairs
<input type="checkbox"/>	Balanced Unscreened	Voltage	AAN	≤ 4
<input type="checkbox"/>	Balanced Unscreened	Voltage and Current	CVP & Current probe	>4 or unable to AAN
<input type="checkbox"/>	Screened or Coaxial	Voltage	AAN	N/A
<input type="checkbox"/>	Screened or Coaxial	Voltage or Current	Current probe / “150Ω to 50Ω adaptor” / high impedance probe	N/A
<input type="checkbox"/>	Unbalanced cables	Voltage and Current	CVP & Current probe	N/A

5 Conducted differential voltage emission

Test result: NA

5.1 Limits

Applicability	Frequency range (MHz)	Differential voltage limit @ 75Ω (dBuV)		
		Other	Local Oscillator Fundamental	Local Oscillator Harmonics
Television receivers; video recorders; PC TV broadcast receiver tuner cards; Digital audio receivers;	30 ~ 950	46	46	46
	950 ~ 2150	46	54	54
Tuner units (not the LNB) for satellite signal reception	950 ~ 2150	46	54	54
FM audio receivers and PC tuner cards	30 ~ 300	46	54	50
	300 ~ 1000	46	54	52
FM car radios	30 ~ 300	46	66	59
	300 ~ 1000	46	66	52
RF modulator output ports connect to TV broadcast receiver tuner ports	30 ~ 950	46	76	46
	950 ~ 2150	46	/	54

5.2 Test setup

TV/FM broadcast receiver tuner ports

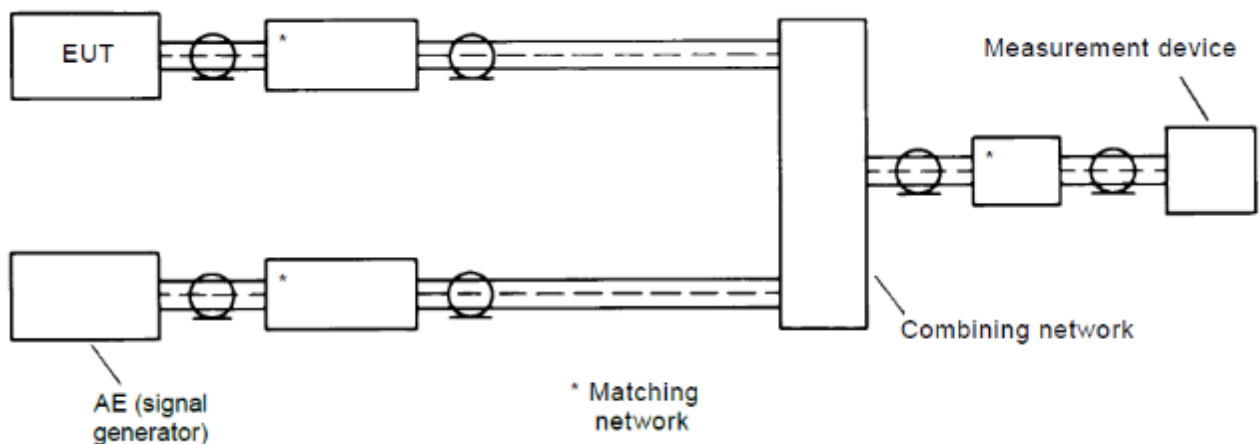

RF modulator output port

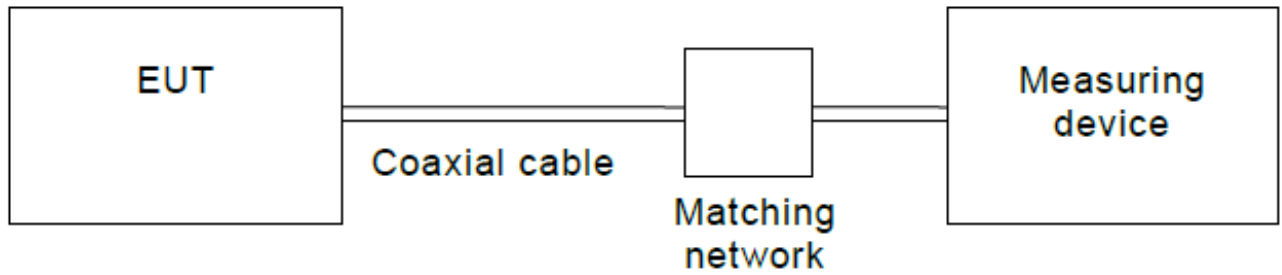

5.3 Test Procedure

Measurement was performed in shielded room, and instruments used were followed EN 55032 clause C4.2 and C4.3.

Detailed test procedure and arrangement was followed EN 55032 clause C.4.2 and C.4.3.

Frequency range 30MHz – 2150MHz was checked and EMI receiver measurement bandwidth was set to 120kHz / 1MHz.

5.4 Test Result

Test Curve:

Test Data:

TV/FM broadcast receiver tuner ports

Receiving Frequency (MHz)	Oscillator Frequency (MHz)	Harmonics No.	Measured dB(μV)	Limits dB(μV)	Result
88.1					
98.1					
107.9					
Other					

RF modulator output port

Frequency (MHz)	Disturbance level dB(μV)	Permitted limit dB(μV)
Harmonics		
Harmonics		
Other		
Other		

6 Radiated emission

Test result: Pass

6.1 Limits

6.1.1 Limits for radiated disturbance of class A Equipment

Frequency (MHz)	Permitted limit in dB μ V/m (Quasi-peak) of Measurement Distance 3m	Permitted limit in dB μ V/m (Quasi-peak) of Measurement Distance 10M
30-230	50	40
230-1000	57	47

Note: for the measurement distance other than 3m and 10m, the limit is varied according to 20dB/10 decades.

Frequency range GHz	Average limit of Measurement Distance 3m dB(μ V/m)	Peak limit of Measurement Distance 3m dB(μ V/m)
1 to 3	56	76
3 to 6	60	80

NOTE The lower limit applies at the transition frequency.

6.1.2 Limits for radiated disturbance of class B Equipment

Frequency (MHz)	Permitted limit in dB μ V/m (Quasi-peak) of Measurement Distance 3m	Permitted limit in dB μ V/m (Quasi-peak) of Measurement Distance 10M
30-230	40	30
230-1000	47	37

Note: for the measurement distance other than 3m and 10m, the limit is varied according to 20dB/10 decades.

Frequency range GHz	Average limit of Measurement Distance 3m dB(μ V/m)	Peak limit of Measurement Distance 3m dB(μ V/m)
1 to 3	50	70
3 to 6	54	74

Note: The lower limit applies at the transition frequency.

6.2 Block diagram of test set up

For table-top equipment

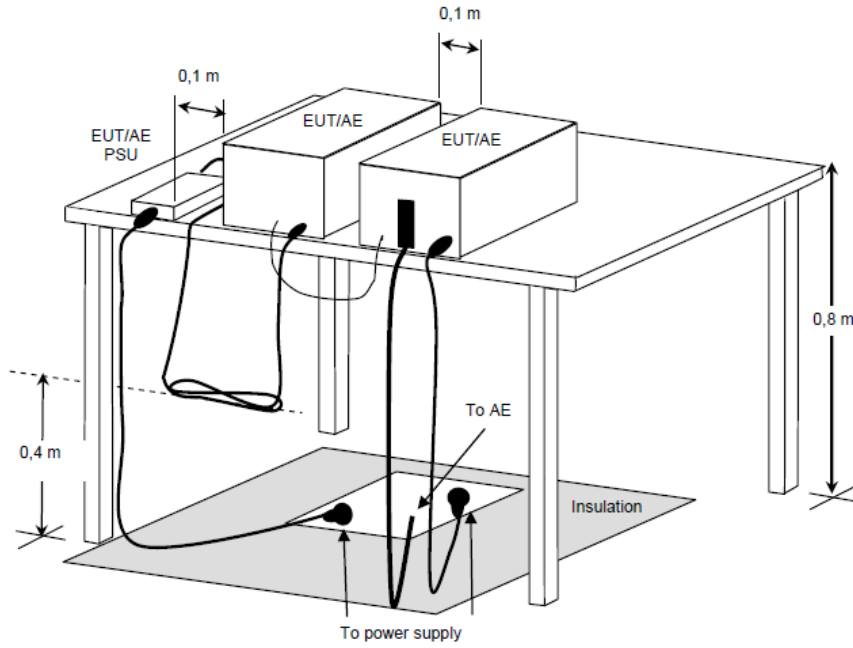

For floor standing equipment

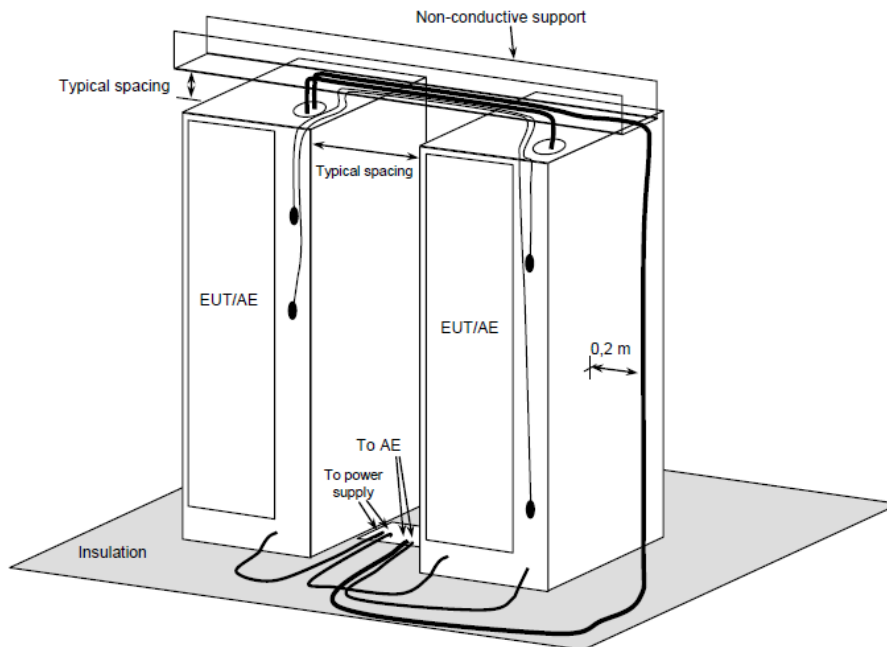

For combination equipment

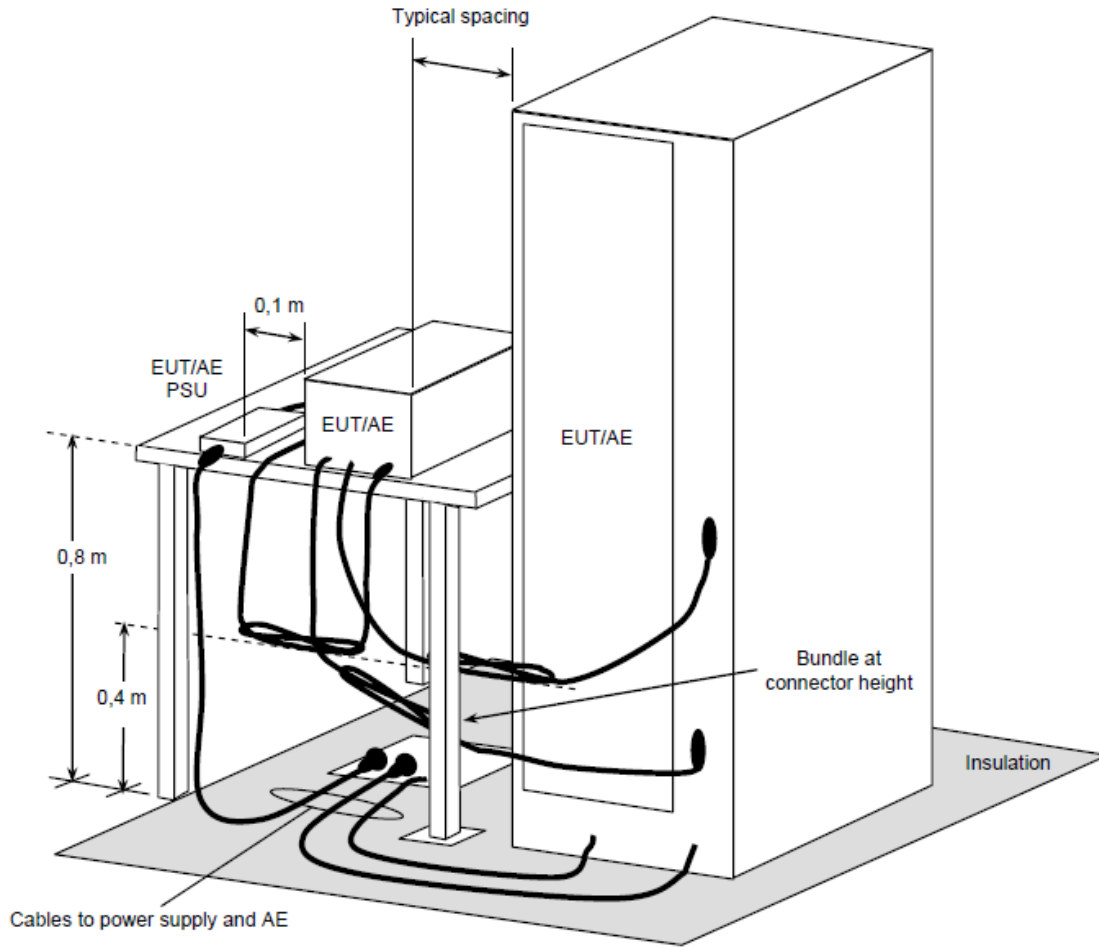

6.3 Test Procedure

The measurement was performed in a semi-anechoic chamber.

The distance from EUT to receiving antenna is 3 meter.

Measurement was performed according to clause 7.3 of CISPR 16-2-3.

Highest internal frequency (F _x)	Highest measured frequency for radiated measurement	Measured Bandwidth
F _x ≤ 108 MHz	1 GHz	120kHz
108 MHz < F _x ≤ 500 MHz	2 GHz	1MHz
500 MHz < F _x ≤ 1 GHz	5 GHz	1MHz
F _x > 1 GHz	5 × F _x up to a maximum of 6 GHz	1MHz

Note: 1. For FM and TV broadcast receivers, F_x is determined from the highest frequency generated or used excluding the local oscillator and tuned frequencies.

2. For outdoor units of home satellite Equipment receiving systems highest measured frequency shall be 18GHz.

6.4 Test Result

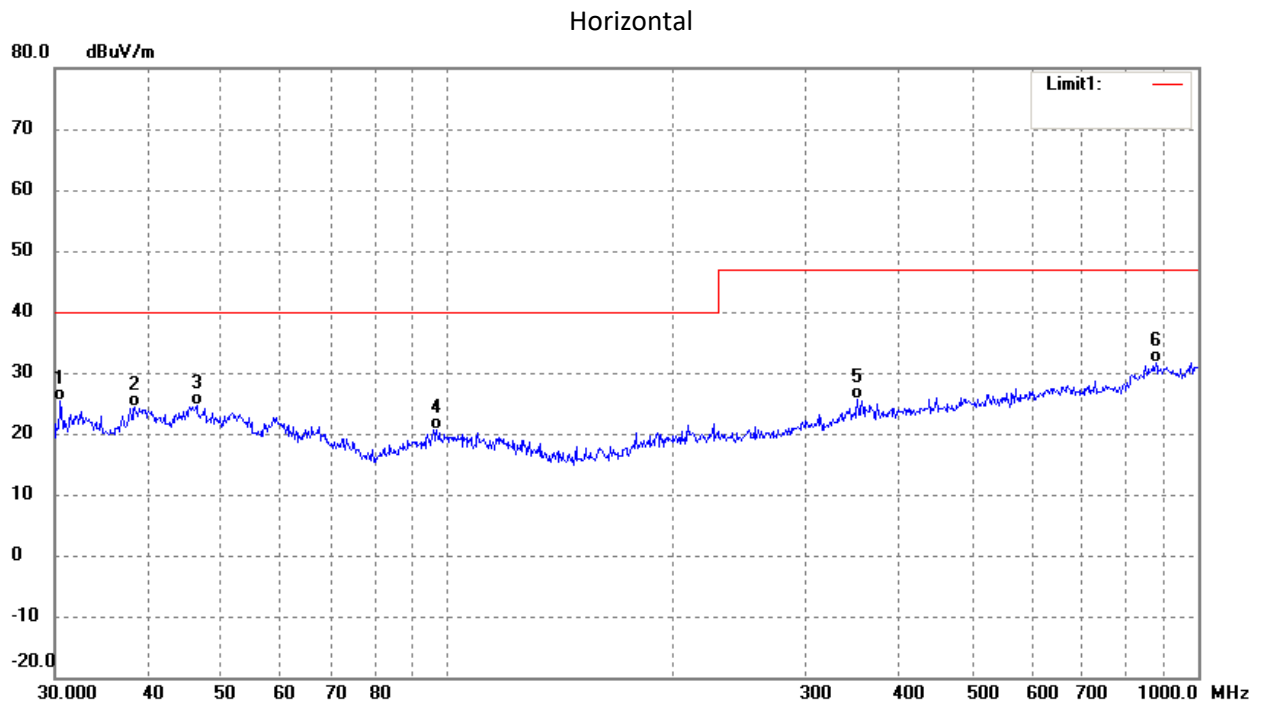

No.	Frequency (MHz)	Reading (dBuV/m)	Correct dB/m	Result (dBuV/m)	Limit (dBuV/m)	Margin (dB)	Remark
1	30.5306	39.43	-14.12	25.31	40.00	-14.69	QP
2	38.3462	36.92	-12.61	24.31	40.00	-15.69	QP
3	46.3402	36.45	-11.73	24.72	40.00	-15.28	QP
4	96.7749	34.51	-13.86	20.65	40.00	-19.35	QP
5	351.7079	32.98	-7.41	25.57	47.00	-21.43	QP
6	878.3214	30.91	0.67	31.58	47.00	-15.42	QP

TEST REPORT

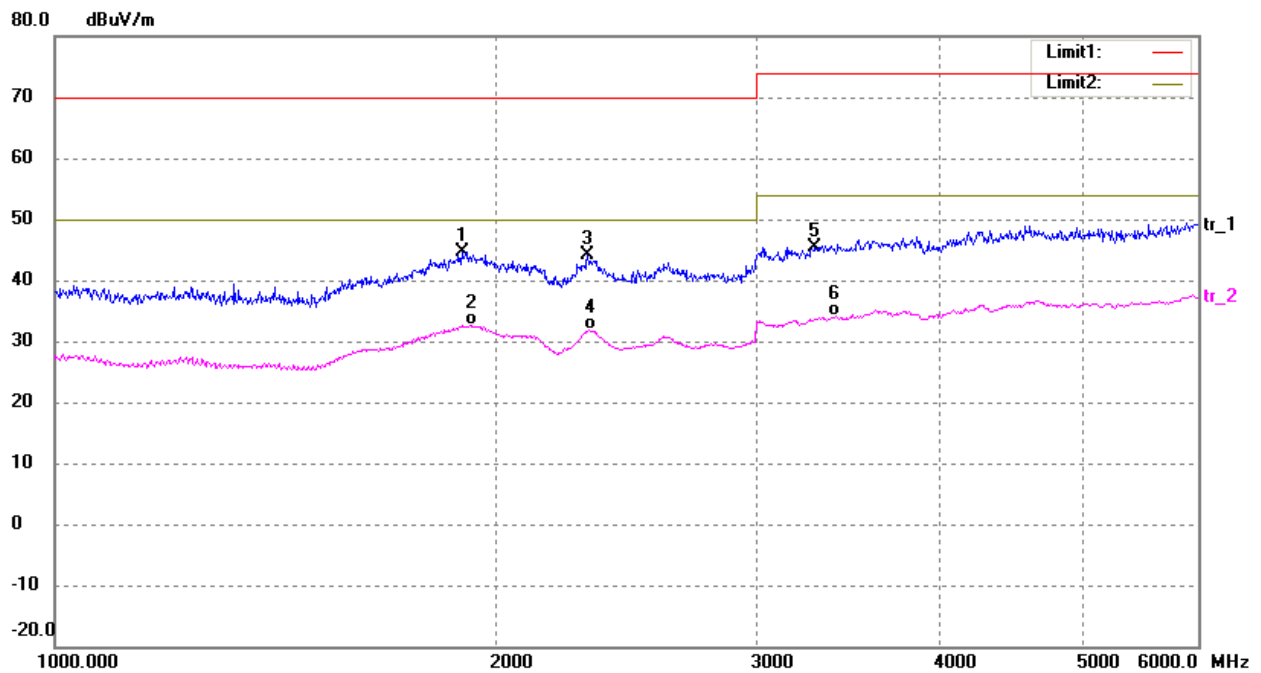

No.	Frequency (MHz)	Reading (dBuV/m)	Correct (dB/m)	Result (dBuV/m)	Limit (dBuV/m)	Margin (dB)	Remark
1	1892.439	53.33	-8.63	44.70	70.00	-25.30	peak
2	1919.761	41.58	-8.89	32.69	50.00	-17.31	AVG
3	2304.722	53.71	-9.68	44.03	70.00	-25.97	peak
4	2308.855	41.50	-9.67	31.83	50.00	-18.17	AVG
5	3292.081	53.29	-7.80	45.49	74.00	-28.51	peak
6	3399.987	41.51	-7.49	34.02	54.00	-19.98	AVG

Vertical

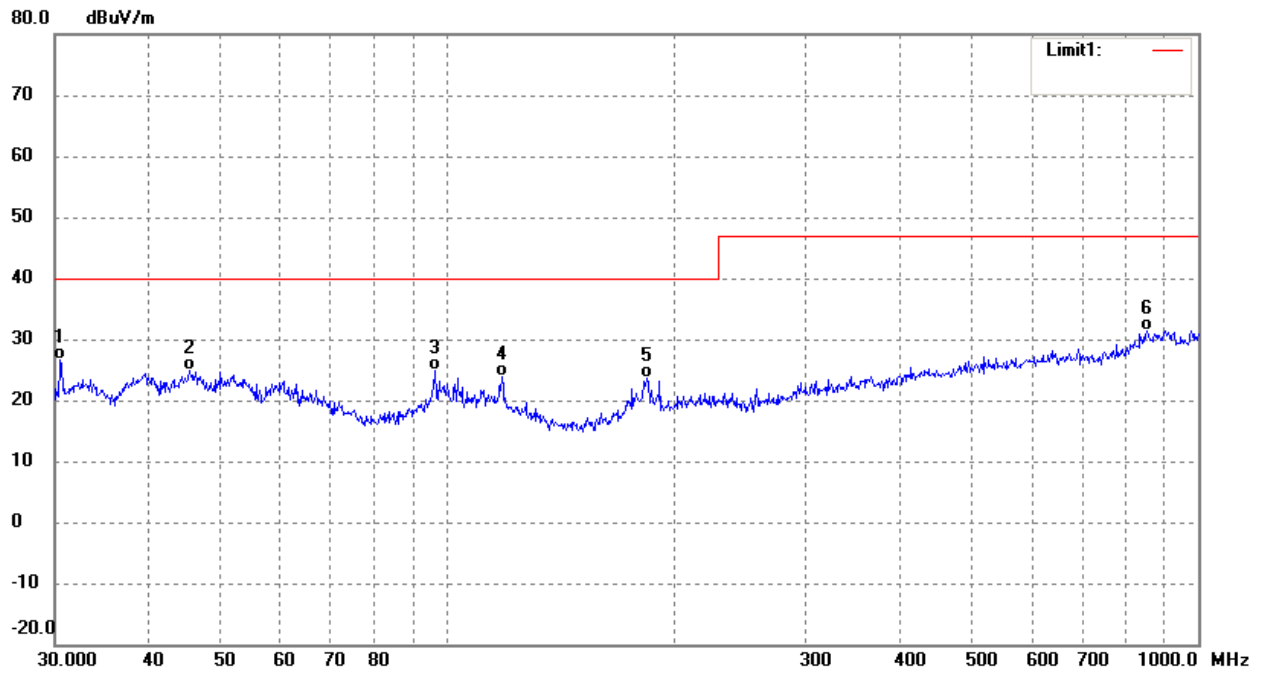

No.	Frequency (MHz)	Reading (dBuV/m)	Correct dB/m	Result (dBuV/m)	Limit (dBuV/m)	Margin (dB)	Remark
1	30.5306	40.77	-14.12	26.65	40.00	-13.35	QP
2	45.3755	36.55	-11.78	24.77	40.00	-15.23	QP
3	96.4362	38.87	-13.91	24.96	40.00	-15.04	QP
4	118.1862	37.98	-14.12	23.86	40.00	-16.14	QP
5	184.4898	37.34	-13.78	23.56	40.00	-16.44	QP
6	854.0247	31.13	0.36	31.49	47.00	-15.51	QP

TEST REPORT

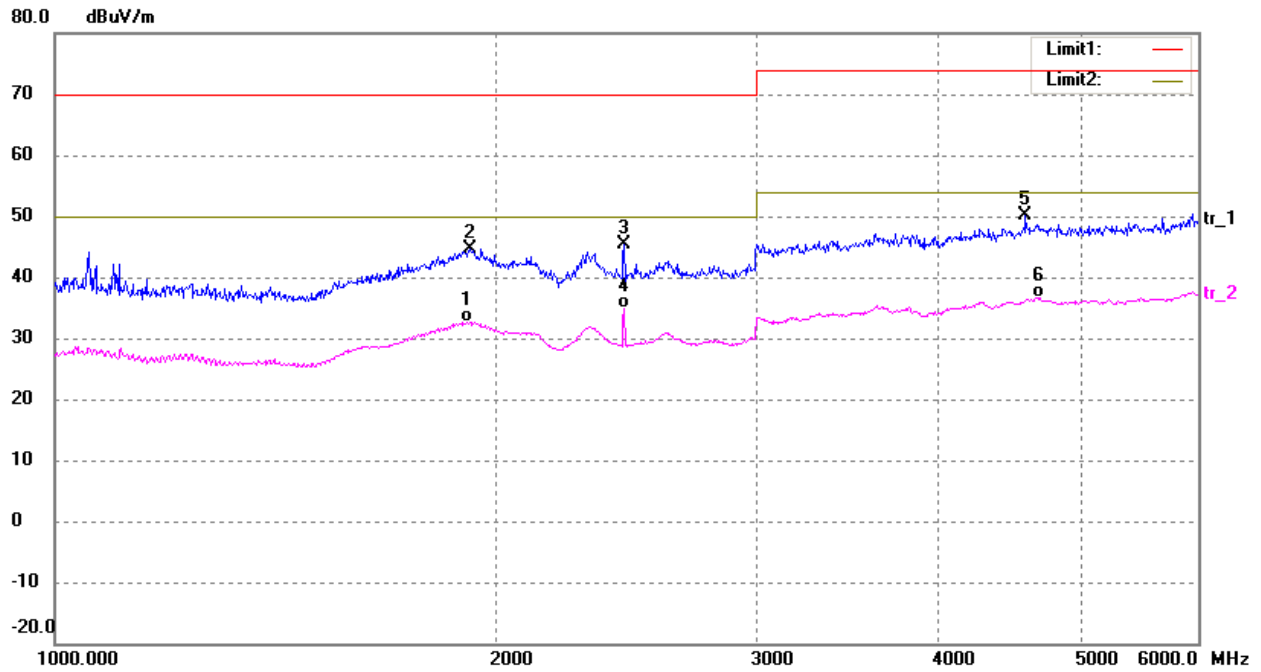

No.	Frequency (MHz)	Reading (dBuV/m)	Correct (dB/m)	Result (dBuV/m)	Limit (dBuV/m)	Margin (dB)	Remark
1	1906.051	41.25	-8.65	32.60	50.00	-17.40	AVG
2	1916.324	53.53	-8.83	44.70	70.00	-25.30	peak
3	2440.728	54.78	-9.40	45.38	70.00	-24.62	peak
4	2440.728	44.37	-9.40	34.97	50.00	-15.03	AVG
5	4577.733	54.74	-4.66	50.08	74.00	-23.92	peak
6	4668.852	41.19	-4.60	36.59	54.00	-17.41	AVG

Test Result of 120VAC

Horizontal

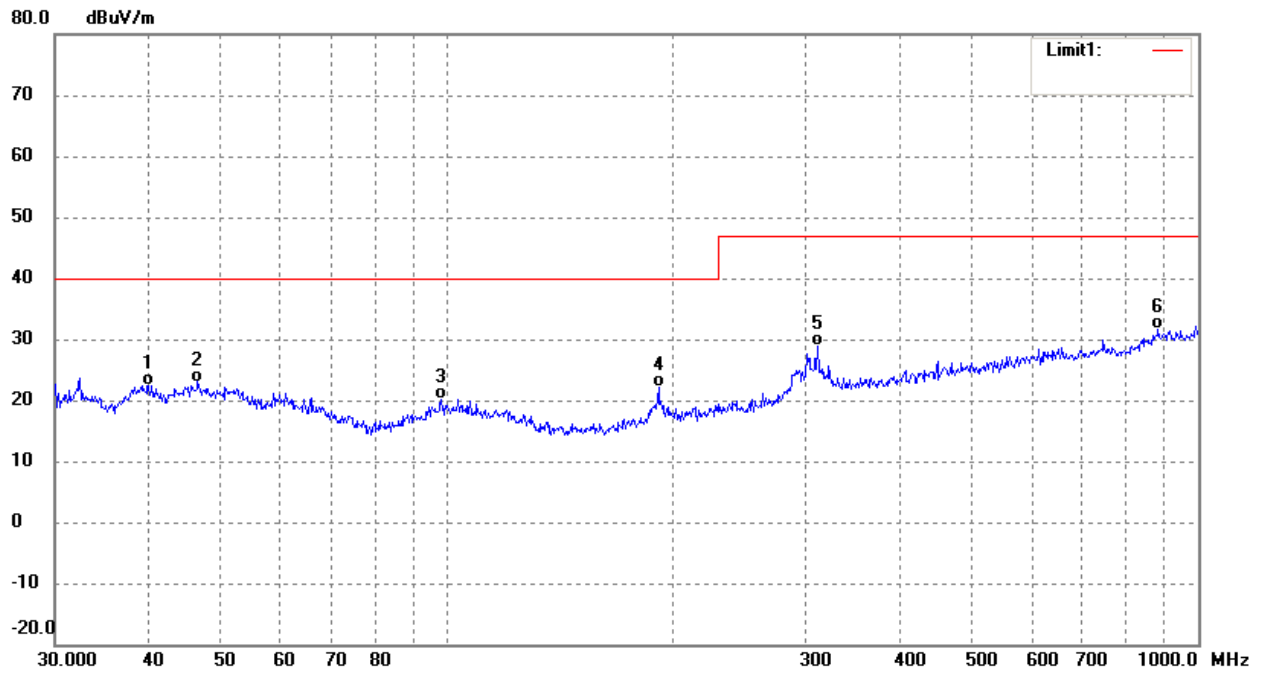

No.	Frequency (MHz)	Reading (dBuV/m)	Correct dB/m	Result (dBuV/m)	Limit (dBuV/m)	Margin (dB)	Remark
1	39.9942	34.44	-11.98	22.46	40.00	-17.54	QP
2	46.5030	34.72	-11.72	23.00	40.00	-17.00	QP
3	98.1419	33.83	-13.62	20.21	40.00	-19.79	QP
4	191.0738	35.21	-13.05	22.16	40.00	-17.84	QP
5	311.0867	37.84	-8.93	28.91	47.00	-18.09	QP
6	884.5029	30.67	0.92	31.59	47.00	-15.41	QP

TEST REPORT

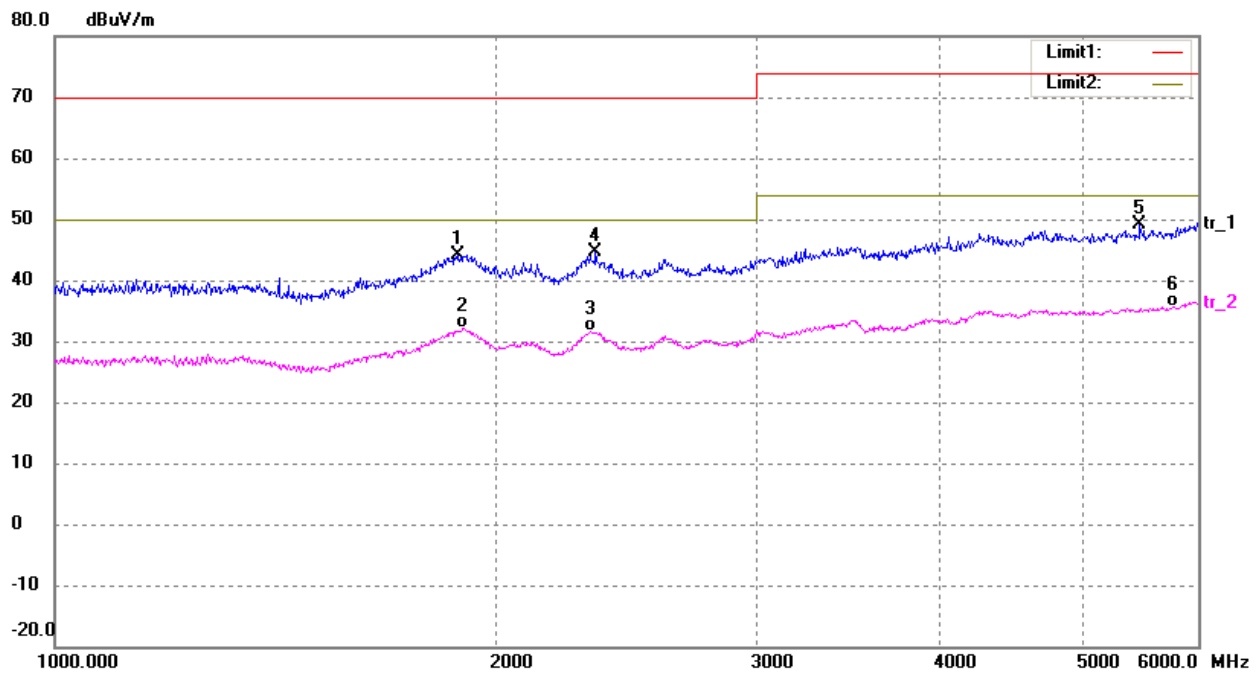

No.	Frequency (MHz)	Reading (dBuV/m)	Correct dB/m	Result (dBuV/m)	Limit (dBuV/m)	Margin (dB)	Remark
1	1882.294	52.91	-8.71	44.20	70.00	-25.80	peak
2	1895.833	40.83	-8.60	32.23	50.00	-17.77	AVG
3	2312.995	41.28	-9.67	31.61	50.00	-18.39	AVG
4	2333.810	54.25	-9.61	44.64	70.00	-25.36	peak
5	5476.026	53.28	-4.15	49.13	74.00	-24.87	peak
6	5768.089	39.21	-3.53	35.68	54.00	-18.32	AVG

Vertical

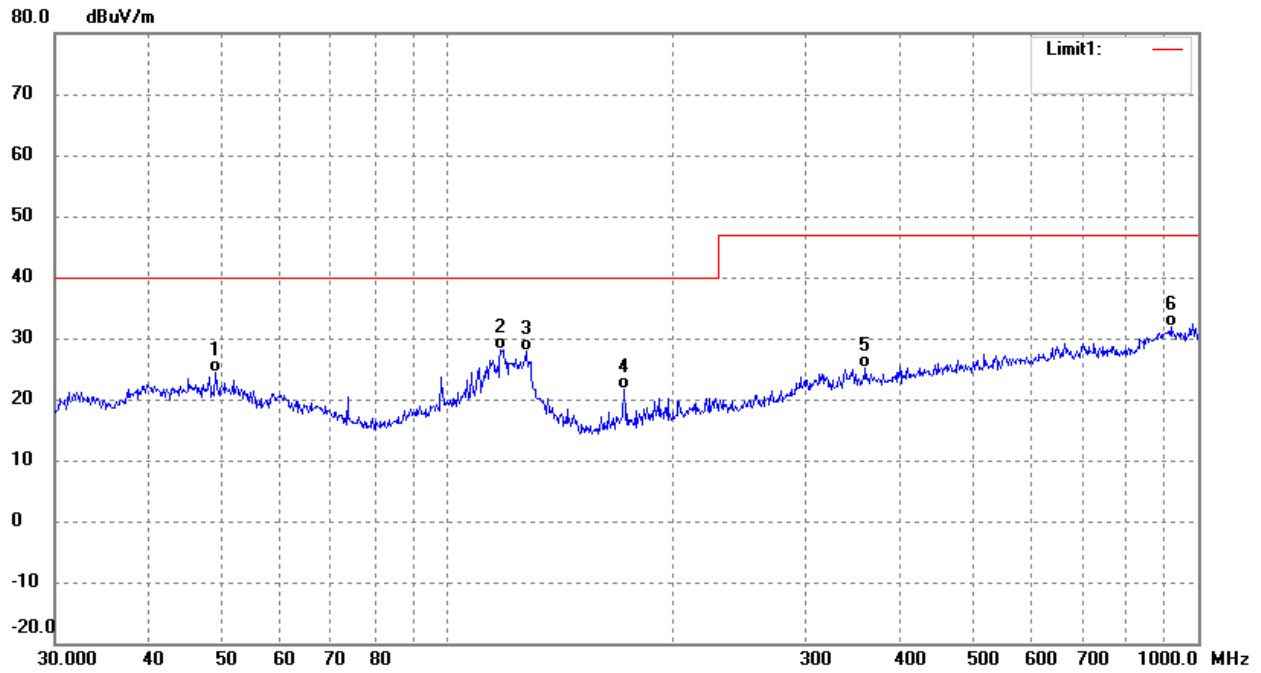

No.	Frequency (MHz)	Reading (dBuV/m)	Correct dB/m	Result (dBuV/m)	Limit (dBuV/m)	Margin (dB)	Remark
1	49.1866	35.96	-11.58	24.38	40.00	-15.62	QP
2	117.7725	42.28	-14.07	28.21	40.00	-11.79	QP
3	127.2176	44.09	-16.22	27.87	40.00	-12.13	QP
4	171.9946	36.56	-14.88	21.68	40.00	-18.32	QP
5	360.4477	32.45	-7.34	25.11	47.00	-21.89	QP
6	919.2866	30.06	1.78	31.84	47.00	-15.16	QP

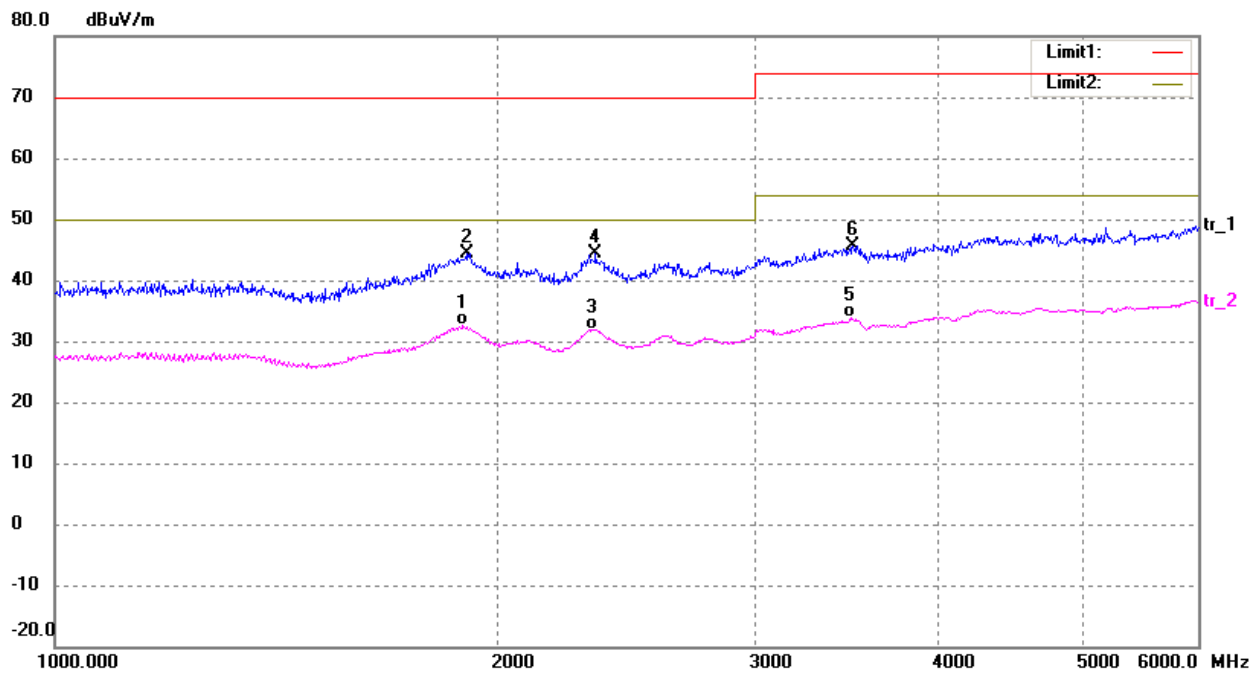

No.	Frequency (MHz)	Reading (dBuV/m)	Correct dB/m	Result (dBuV/m)	Limit (dBuV/m)	Margin (dB)	Remark
1	1895.833	41.21	-8.60	32.61	50.00	-17.39	AVG
2	1906.051	53.12	-8.65	44.47	70.00	-25.53	peak
3	2321.299	41.48	-9.63	31.85	50.00	-18.15	AVG
4	2333.810	53.99	-9.61	44.38	70.00	-25.62	peak
5	3480.112	41.02	-7.25	33.77	54.00	-20.23	AVG
6	3492.606	52.78	-7.22	45.56	74.00	-28.44	peak

Remark: 1. Correct Factor = Antenna Factor + Cable Loss (+ Amplifier, for higher than 1GHz), the value was added to Original Receiver Reading by the software automatically.

2. Corrected Reading = Original Receiver Reading + Correct Factor

3. Margin = Limit - Corrected Reading

4. If the PK Corrected Reading is lower than AV limit, the AV test can be elided.

Example: Assuming Antenna Factor = 30.20dB/m, Cable Loss = 2.00dB,
Gain of Preamplifier = 32.00dB, Original Receiver Reading = 10.00dBuV,
Limit = 40.00dBuV/m.

Then Correct Factor = 30.20 + 2.00 – 32.00 = 0.20dB/m;

Corrected Reading = 10dBuV + 0.20dB/m = 10.20dBuV/m;

Margin = 40.00dBuV/m - 10.20dBuV/m = 29.80dB.

7 Harmonic current emission

Test result: Pass

7.1 Test Setup

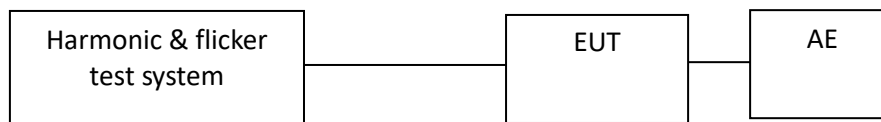

7.2 Test Procedure

Harmonics of the fundamental current were measured up to 40 order harmonics using a digital power meter with an analogue output and frequency analyzer which was integrated in the harmonic & flicker test system. The measurements were carried out under steady conditions.

Measuring instrumentation according to IEC 61000-4-7:2002+A1:2008

This product is not defined as lighting equipment, and has rated power less than 75W, therefore, no limit applies according to EN 61000-3-2

The EUT is kitchen machines as listed in the scope of IEC 60335-2-14, therefore, is deemed to conform to the harmonic current limits of this standard without further testing.

7.3 Test Result

Pass

8 Voltage fluctuations and flicker

Test result: Pass

8.1 Test Setup

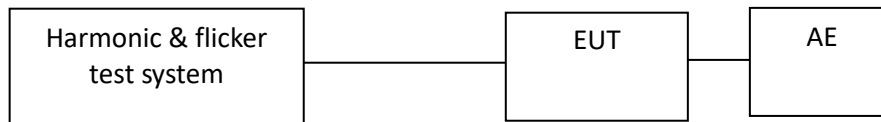

8.2 Test Procedure

8.2.1 Definition

Flicker: impression of unsteadiness of visual sensation induced by a lighting stimulus whose luminance or spectral distribution fluctuates with time.

Pst: Short-term flicker indicator the flicker severity evaluated over a short period (in minutes); Pst=1 is the conventional threshold of irritability

Plt: long-term flicker indicator; the flicker severity evaluated over a long period (a few hours) using successive Pst values.

dc: the relative steady-state voltage change

dmax: the maximum relative voltage change

d(t): the value during a voltage change

8.2.2 Test Procedure

The following limits apply

-- "Plt" shall not exceed 0.65.

-- "Pst" shall not exceed 1.0.

-- "dc" shall not exceed 3.3%.

-- "d(t)" shall not exceed 3.3% for more than 500ms.

-- "dmax" shall not exceed:

4% without additional conditions,

6% switched manually or automatically more than twice per day,

7% attended whilst in use or switched automatically for no more than twice per day or attended while in use.

For manual switch, dmax is measured in accordance with Annex B of standard, average dmax is calculated from 24 times measurement.

The EUT is unlikely to produce significant voltage fluctuations or flicker by technical analysis and evaluation. So it is deemed to fulfil the requirements without testing.

8.3 Test Result

Pass

Immunity Test

Performance criteria

The performance criteria are based on the general criteria of the standard and derived from the product specification

Criteria A: The equipment shall continue to operate as intended without operator intervention. No degradation of performance, loss of function or change of operating state is allowed below a performance level specified by the manufacturer when the equipment is used as intended. The performance level may be replaced by a permissible loss of performance. If the minimum performance level or the permissible performance loss is not specified by the manufacturer, then either of these may be derived from the product description and documentation, and by what the user may reasonably expect from the equipment if used as intended.

Criteria B: During the application of the disturbance, degradation of performance is allowed. However, no unintended change of actual operating state or stored data is allowed to persist after the test. After the test, the equipment shall continue to operate as intended without operator intervention; no degradation of performance or loss of function is allowed, below a performance level specified by the manufacturer, when the equipment is used as intended. The performance level may be replaced by a permissible loss of performance.

If the minimum performance level (or the permissible performance loss), or recovery time, is not specified by the manufacturer, then either of these may be derived from the product description and documentation, and by what the user may reasonably expect from the equipment if used as intended.

Criteria C: Loss of function is allowed, provided the function is self-recoverable, or can be restored by the operation of the controls by the user in accordance with the manufacturer's instructions. A reboot or re-start operation is allowed.

Information stored in non-volatile memory, or protected by a battery backup, shall not be lost.

9 Electrostatic Discharges (ESD)

Test result **Pass**

9.1 Severity Level and Performance Criterion

9.1.1 Test level

Contact discharge		Air discharge	
Level	Test voltage (kV)	Level	Test voltage (Kv)
1	2	1	2
2	4	2	4
3	6	3	8
4	8	4	15
X	Special	X	Special

Notes: 1. "X" is an open level. The level has to be specified in the dedicated equipment specification. If higher voltages than those shown are specified, special test equipment may be needed.
 2. The gray rows were the selected test level.

9.1.2 Performance Criterion

Criterion B

9.2 Test Setup

For table-top equipment

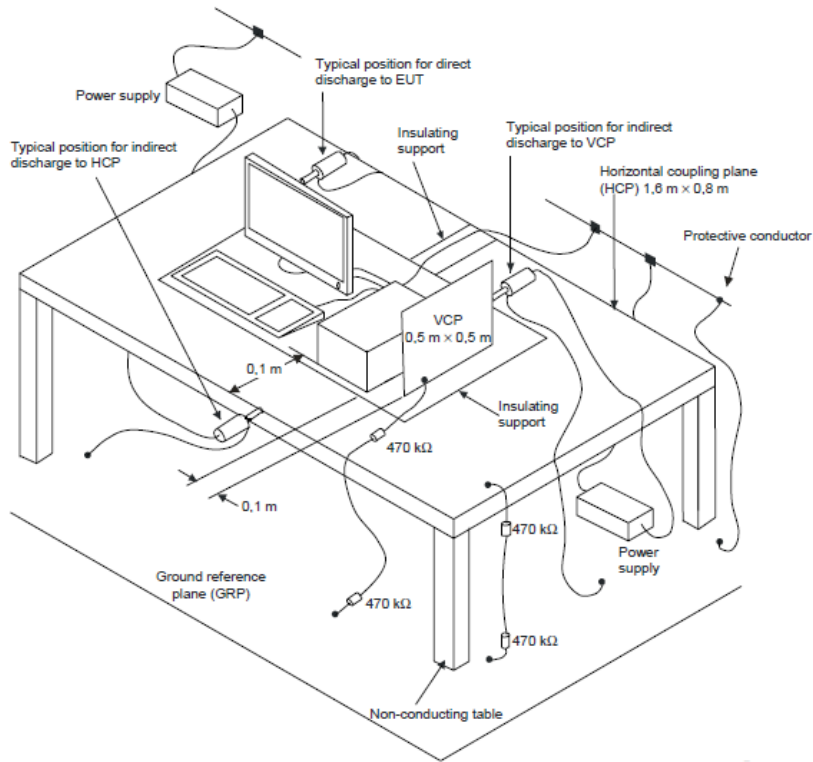

For floor standing equipment

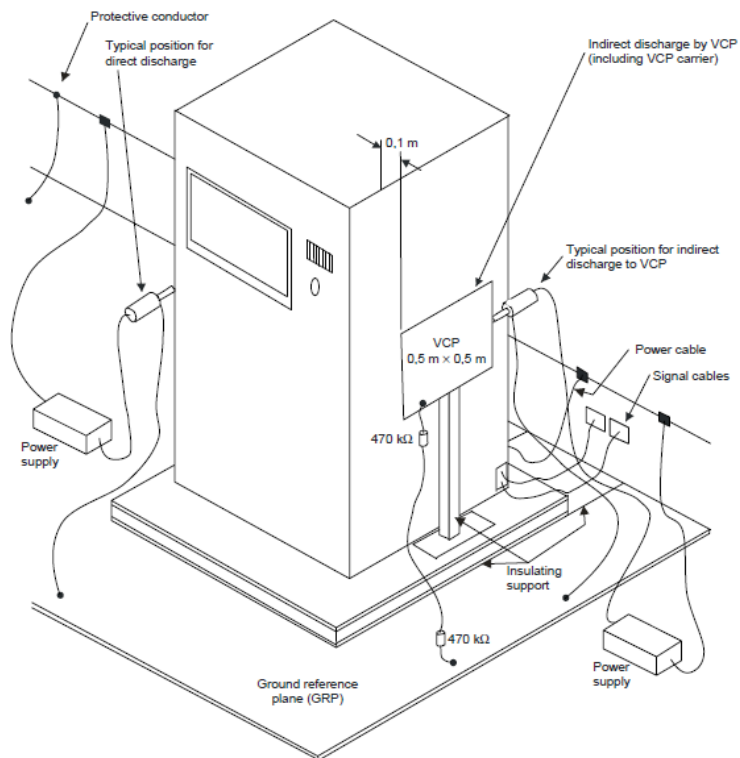

9.3 Test Procedure

Measurement was performed in shielded room.

Measurement procedure was applied according to EN 61000-4-2 clause 8.

The test method and equipment was specified by EN 61000-4-2.

9.4 Test Result

Direct discharges were applied at the following selected points:

Test level [kV]	Air/Contact	Polarity (+/-)	Pass/Fail/NA	Comment
4	Contact	+/-	Pass	Accessible metal parts of the EUT
4	Contact	+/-	Pass	All touchable screws of enclosure
2/4/8	Air	+/-	Pass	Air gap of the switch, button
2/4/8	Air	+/-	Pass	Slots around the EUT

Indirect contact discharges were applied to the VCP and the HCP at the following selected points:

For table-top equipment

Position	Description	Point	Pass/Fail/NA
HCP front	0,1m from the front of the EUT	Edge of centre on HCP	Pass
HCP back	0,1m from the back of the EUT	Edge of centre on HCP	Pass
HCP right	0,1m from the right side of the EUT	Edge of centre on HCP	Pass
HCP left	0,1m from the left side of the EUT	Edge of centre on HCP	Pass
VCP front	0,1m from the front of the EUT	Edge of centre on VCP	Pass
VCP back	0,1m from the back of the EUT	Edge of centre on VCP	Pass
VCP right	0,1m from the right of the EUT	Edge of centre on VCP	Pass
VCP left	0,1m from the left of the EUT	Edge of centre on VCP	Pass

For floor standing equipment

Position	Description	Point	Pass/Fail/NA
CP front	0,1m from the front of the EUT	Edge of centre on VCP	NA
CP back	0,1m from the back of the EUT	Edge of centre on VCP	NA
CP right	0,1m from the right of the EUT	Edge of centre on VCP	NA
CP left	0,1m from the left of the EUT	Edge of centre on VCP	NA

Observation: All the functions were operated as normal during and after test.

Conclusion: The EUT can meet the requirement of Performance Criterion B.

10 Continuous RF disturbances

Test result

Pass

10.1 Severity Level and Performance Criterion

10.1.1 Test level

Level	Test field strength V/m
1	1
2	3
3	10
X	Special

Note: 1. X is an open test level. This level may be given in the product specification.
2. The gray row is the selected test level.

10.1.2 Performance Criterion

Criterion A

10.2 Test Setup

For table-top equipment

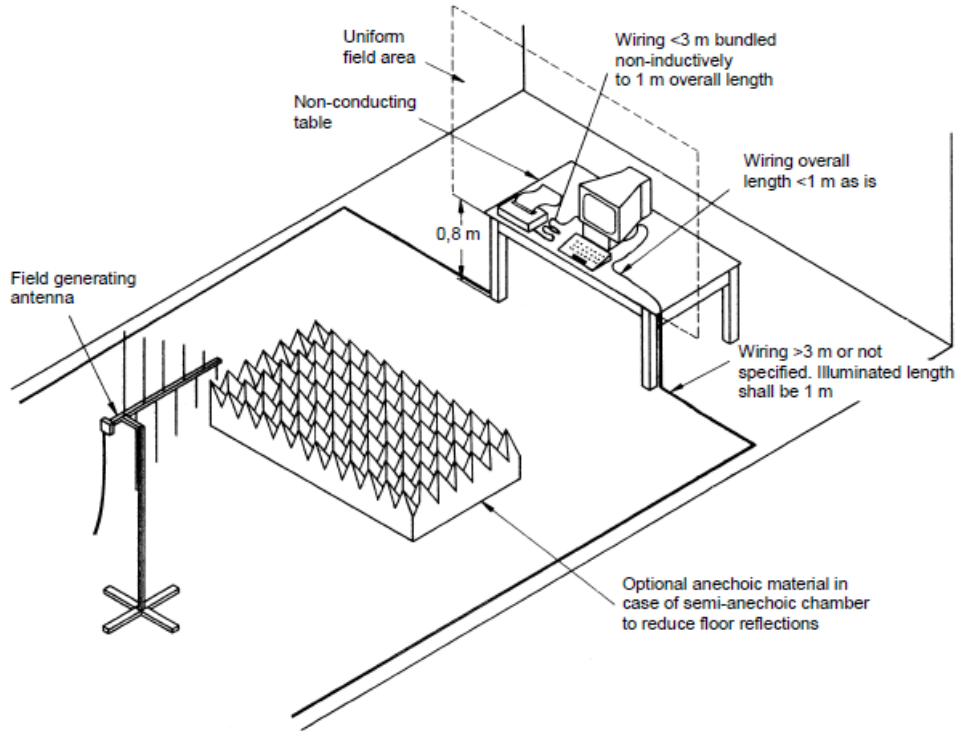

For floor standing equipment

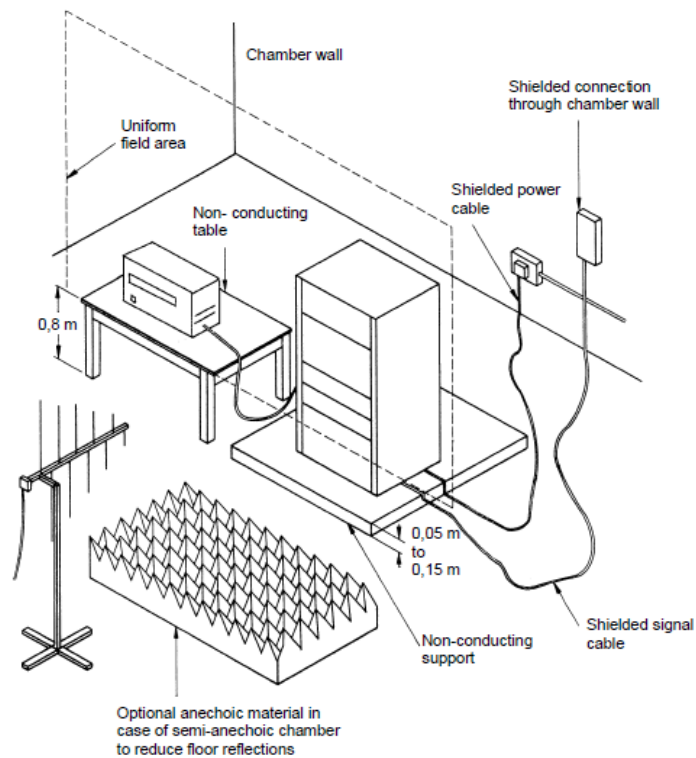

10.3 Test Procedure

Measurement was performed in full-anechoic chamber.

Measurement procedure was applied according to EN 61000-4-3 clause 8.

The test method and equipment was specified by EN 61000-4-3.

10.4 Test Result

Test no.	Frequency (MHz)	Polarization	Test level (V/m)	Modulation	Exposed location	Pass/Fail/NA
1	80-1000	H & V	3	1 kHz, 80% AM 1 % increment	All sides	Pass
2	1800	H & V	3	1 kHz, 80% AM 1 % increment	All sides	Pass
3	2600	H & V	3	1 kHz, 80% AM 1 % increment	All sides	Pass
4	3500	H & V	3	1 kHz, 80% AM 1 % increment	All sides	Pass
5	5000	H & V	3	1 kHz, 80% AM 1 % increment	All sides	Pass

Observation: All the functions were operated as normal during and after test.

Conclusion: The EUT can meet the requirement of Performance Criterion A

11 Continuous induced RF disturbances

Test result Pass

11.1 Severity Level and Performance Criterion

11.1.1 Test level

Test specification	
Frequency range (MHz)	Test level (V)
0.15~10	3
10~30	3 to 1
30~80	1

11.1.2 Performance Criterion

Criterion A

11.2 Block Diagram of Test Setup

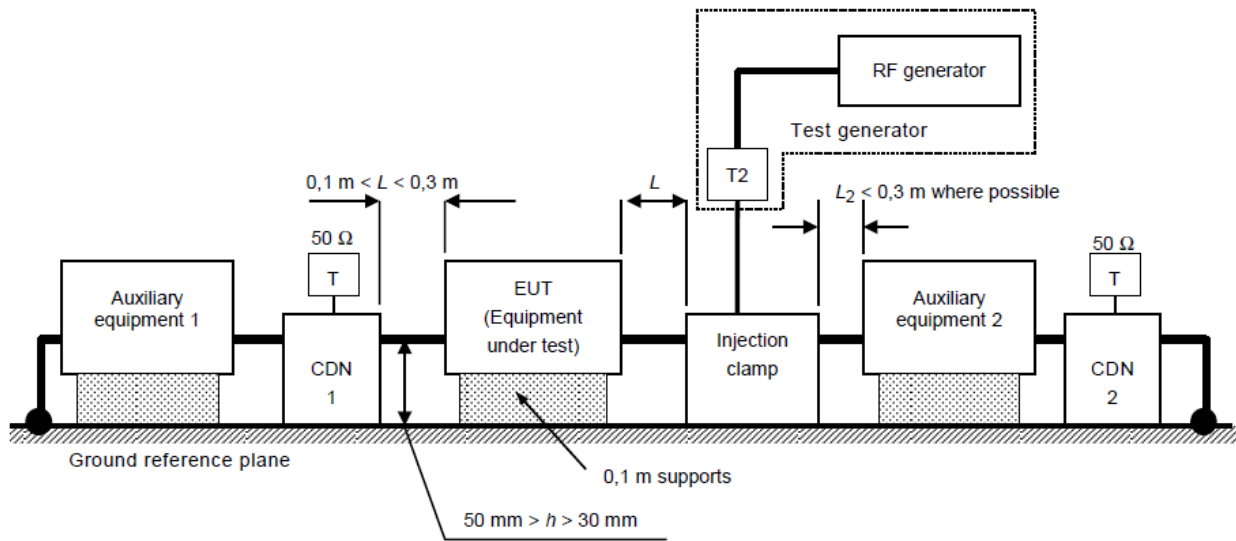
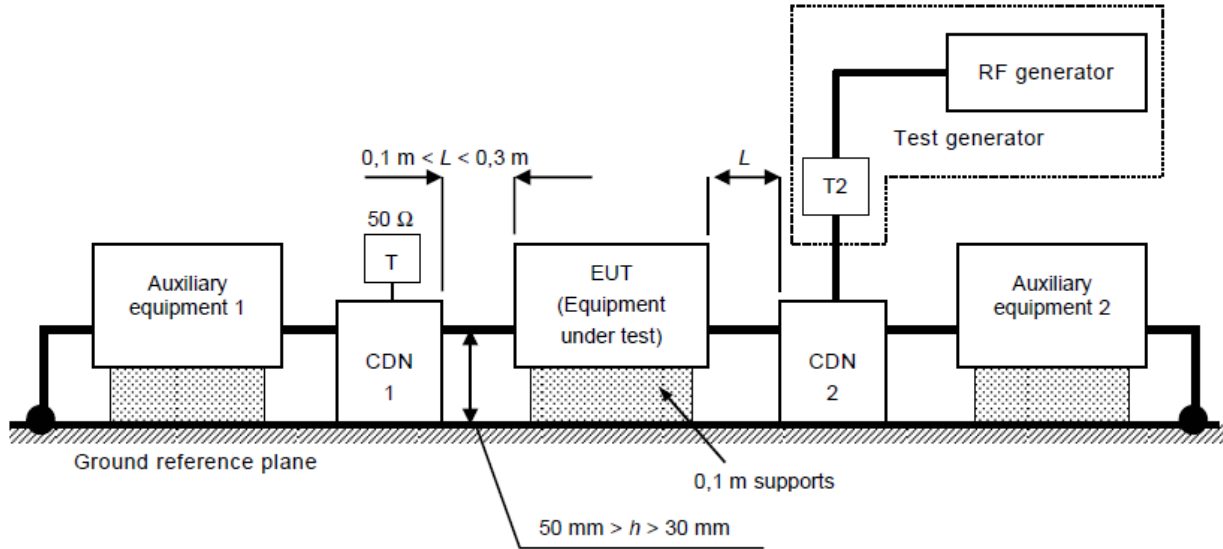

- T termination 50 Ω
- T2 power attenuator (6 dB)
- CDN coupling and decoupling network

11.3 Test Procedure

Measurement procedure was applied according to EN 61000-4-6 clause 8.
The test method and equipment was specified by EN 61000-4-6.

11.4 Test Result

Test No.	Frequency (MHz)	Level (V)	Modulation	Injected point	Pass/Fail/NA
1	0.15~10	3	80%, 1 kHz, AM	AC mains power ports	Pass
2	10~30	3 to 1	80%, 1 kHz, AM	AC mains power ports	Pass
3	30~80	1	80%, 1 kHz, AM	AC mains power ports	Pass
4	0.15~10	3	80%, 1 kHz, AM	DC network power ports	NA
5	10~30	3 to 1	80%, 1 kHz, AM	DC network power ports	NA
6	30~80	1	80%, 1 kHz, AM	DC network power ports	NA
7	0.15~10	3	80%, 1 kHz, AM	analogue/digital data ports	NA
8	10~30	3 to 1	80%, 1 kHz, AM	analogue/digital data ports	NA
9	30~80	1	80%, 1 kHz, AM	analogue/digital data ports	NA

Observation: All the functions were operated as normal during and after test.

Conclusion: The EUT can meet the requirement of Performance Criterion A

12 Power Frequency Magnetic field

Test result **NA**

12.1 Severity Level and Performance Criterion

12.1.1 Test level

Level	Magnetic field strength A/m
1	1
2	3
3	10
4	30
5	100
X	Special

Note: 1. X is an open test level; this level may be given in the product specification.
 2. The gray row is the selected test level.

12.1.2 Performance Criterion

Criterion A

12.2 Test Setup

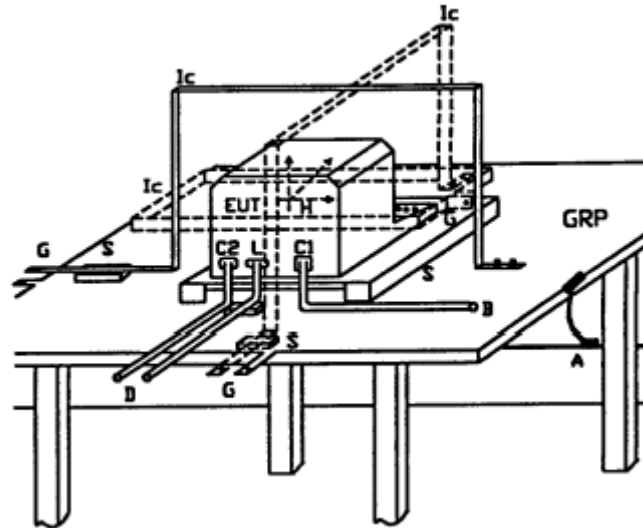

12.3 Test Procedure

Measurement was performed in shielded room.

Measurement procedure was applied according to EN 61000-4-8 clause 8.

The test method and equipment was specified by EN 61000-4-8.

12.4 Test Result

Test No.	Level A/m	Axis	Result	Comment
1	1	X		
2	1	Y		
3	1	Z		

Observation:**Conclusion:**

13 Electrical fast transients/burst

Test result **Pass**

13.1 Severity Level and Performance Criterion

13.1.1 Test level

Open circuit output test voltage and repetition rate of the impulses				
Level	AC mains power input ports		Signal ports, wired network ports, control ports, DC power input ports	
	Voltage peak (kV)	Repetition rate (kHz)	Voltage peak (kV)	Repetition rate (kHz)
1	0.5	5	0.25	5/100
2	1	5	0.5	5/100
3	2	5	1	5/100
4	4	2.5	2	5/100
X	Special	Special	Special	Special

Notes: 1. "X" is an open level. The level has to be specified in the dedicated equipment specification.
 2. The gray rows were the selected test level.

13.1.2 Performance Criterion

Criterion B

13.2 Test Setup

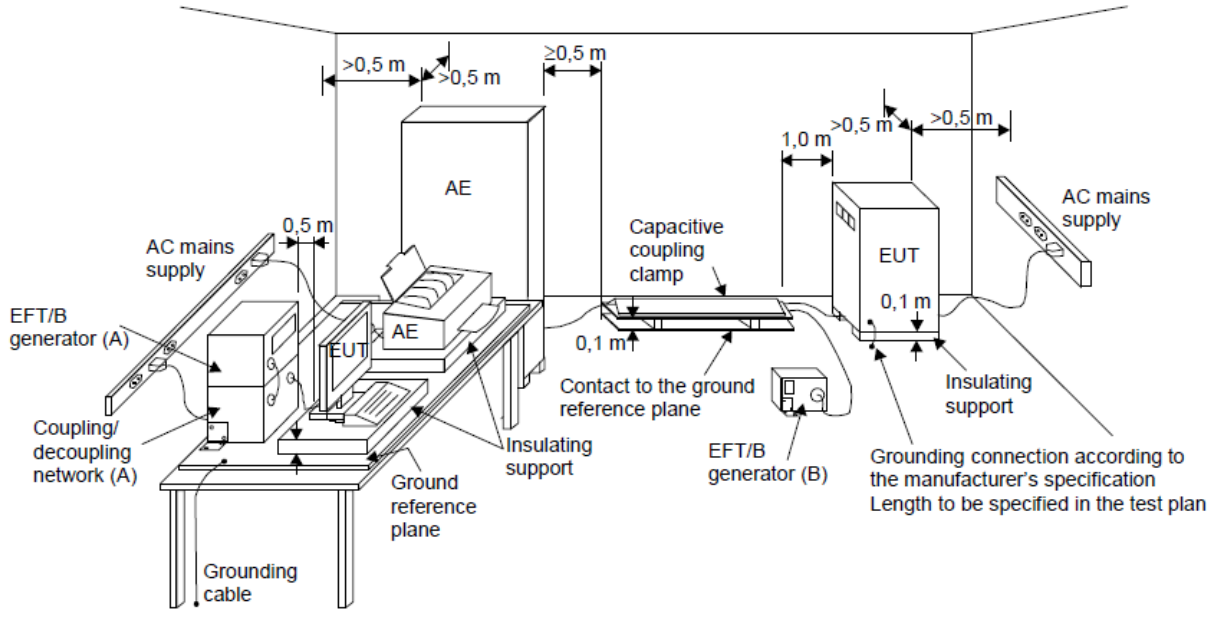

- (A) location for supply line coupling
- (B) location for signal lines coupling

13.3 Test Procedure

Measurement was performed in shielded room.
 Measurement procedure was applied according to EN 61000-4-4 clause 8.
 The test method and equipment was specified by EN 61000-4-4.

13.4 Test Result

Test No.	Level (kV)	Polarity (+/-)	Line for test	Pass/Fail/NA
1	1	+/-	AC mains power input ports	Pass
2	0.5	+/-	DC power input ports	NA
4	0.5	+/-	analogue/digital data ports	NA

Observation: All the functions were operated as normal after the test.

Conclusion: The EUT can meet the requirement of Performance Criterion B

14 Surges

Test result Pass

14.1 Severity Level and Performance Criterion

14.1.1 Test level

Level	Open-circuit test voltage (kV)
1	0.5
2	1.0
3	2.0
4	4.0
X*	Special

Notes: 1. "X" is an open class. This level can be specified in the product specification
 2. The gray rows are the selected level.

14.1.2 Performance Criterion

Criterion B

14.2 Test Setup

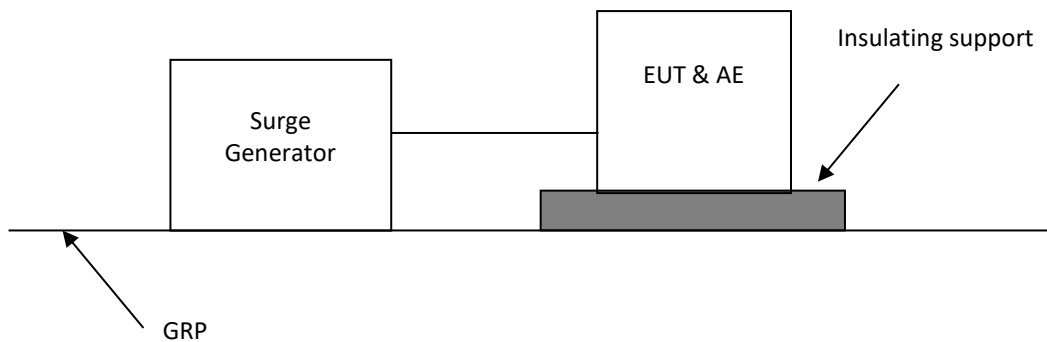

14.3 Test Procedure

Measurement was performed in shielded room.

Measurement procedure was applied according to EN 61000-4-5 clause 8.

The test method and equipment was specified by EN 61000-4-5.

14.4 Test Result

Test No.	Level [kV]	Polarity +/-	Line for test	Pass/Fail/NA
1	0.5/1	+/-	AC mains power ports (line to line)	Pass
2	0.5/1/2	+/-	AC mains power ports (line to earth)	NA
3	0.5	+/-	DC network power ports (line to earth)	NA
4	1/4	+/-	unshielded symmetrical ports(line to ground)	NA
5	0.5	+/-	coaxial or shielded ports(shield to ground)	NA

Observation: All the functions were operated as normal after the test.

Conclusion: The EUT can meet the requirement of Performance Criterion B

15 Voltage dips and interruptions

Test result **NA**

15.1 Severity Level and Performance Criterion

15.1.1 Test level and performance criterion

Test level (% Ut)	Voltage dip and short interruptions (% Ut)	Duration (in period)	Performance criterion
0	100	0.5	B
0	100	250 for 50 Hz / 300 for 60 Hz	C
70	30	25 for 50 Hz / 30 for 60 Hz	C

Notes: The gray rows are selected test level.

15.2 Test Setup

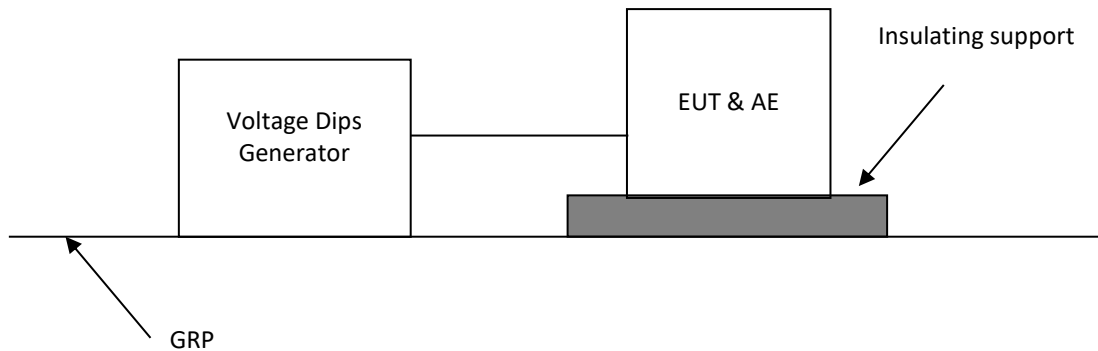

15.3 Test Procedure

Measurement was performed in shielded room.

Measurement procedure was applied according to EN 61000-4-11 clause 8.

The test method and equipment was specified by EN 61000-4-11.

15.4 Test Result

Test no.	Dips to (% Ut)	Voltage dip and short interruptions (% Ut)	Duration (in periods)	Pass/Fail/NA
1	70	30%	25	Pass
2	0	100%	0.5	Pass
3	0	100%	250	Pass

Observation: All the functions were operated as normal after test.

Conclusion: The EUT can meet the requirements of the standard

16 Broadband impulsive conducted disturbances

Test result NA

16.1 Severity Level and Performance Criterion

16.1.1 Test level

Broadband impulse noise disturbances, repetitive	
Frequency range(MHz)	Level(V)
0.15~0.5	107
0.5~10	107~36
10~30	36~30

Broadband impulse noise disturbances, isolated	
Frequency range(MHz)	Level(V)
0.15~30	110

16.1.2 Performance Criterion

Broadband impulse noise disturbances, repetitive: Criterion A

Broadband impulse noise disturbances, isolated: Criterion B

16.2 Test Setup

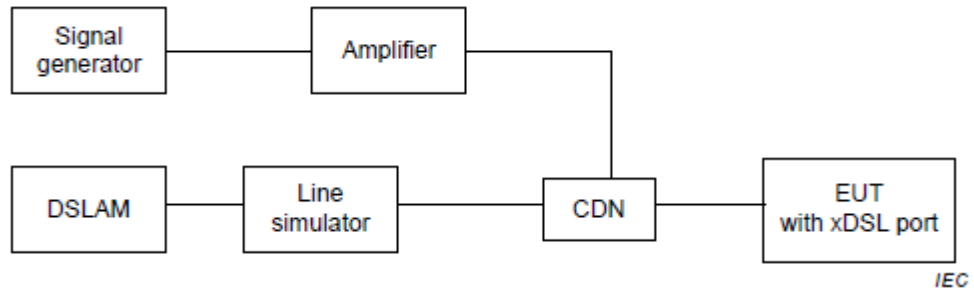

16.3 Test Procedure

Measurement procedure was applied according to EN 55035 clause 4.2.7.
The test method and equipment was specified by EN 55035 clause 4.2.7.

16.4 Test Result

Test No.	Frequency [MHz]	Level [dB μ V]	Burst period [ms]	Impulse type	Pass/Fail/NA
1	0.15~0.5	107	10(for 50Hz) 8.3(for 60Hz)	repetitive	NA
2	0.5~10	107~36	10(for 50Hz) 8.3(for 60Hz)	repetitive	NA
3	10~30	36~30	10(for 50Hz) 8.3(for 60Hz)	repetitive	NA

Observation:

Conclusion:

Test No.	Frequency [MHz]	Level [dB μ V]	Burst duration [ms]	Impulse type	Pass/Fail/NA
1	0.15~30	110	0.24	isolated	NA
2	0.15~30	110	10	isolated	NA
3	0.15~30	110	300	isolated	NA

Observation:

Conclusion:

Appendix I: Photograph of equipment under test

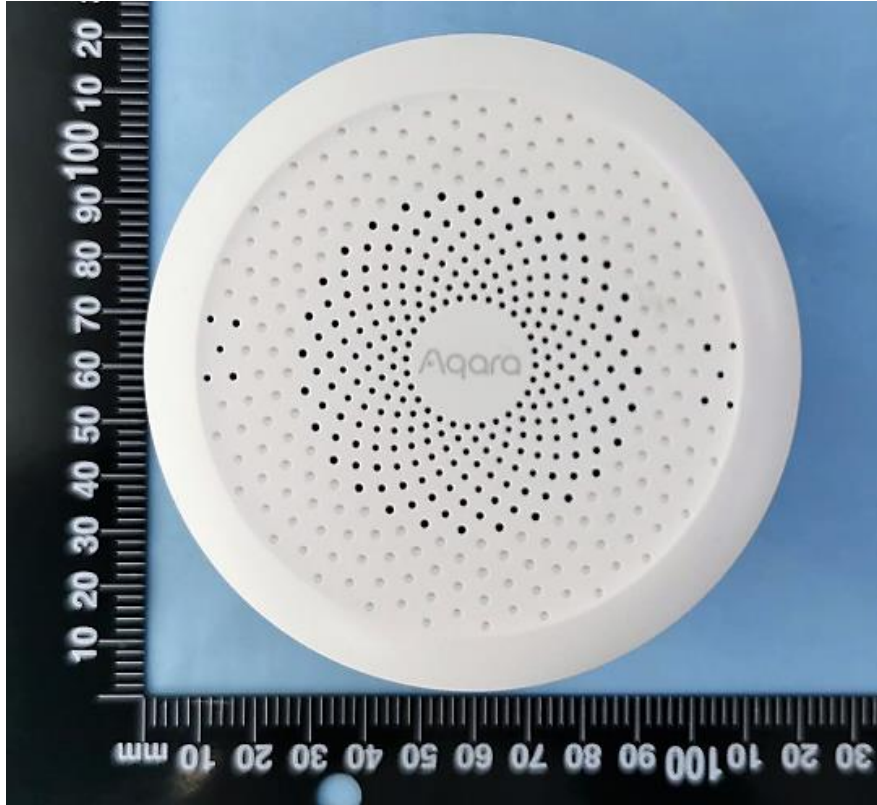





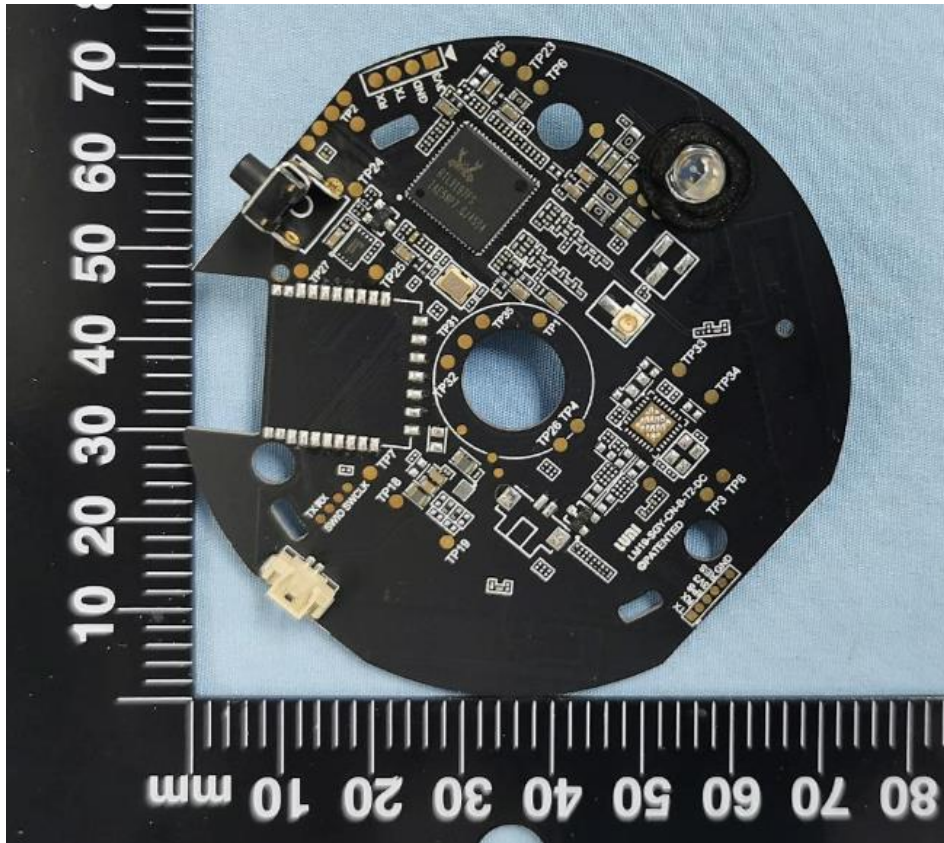
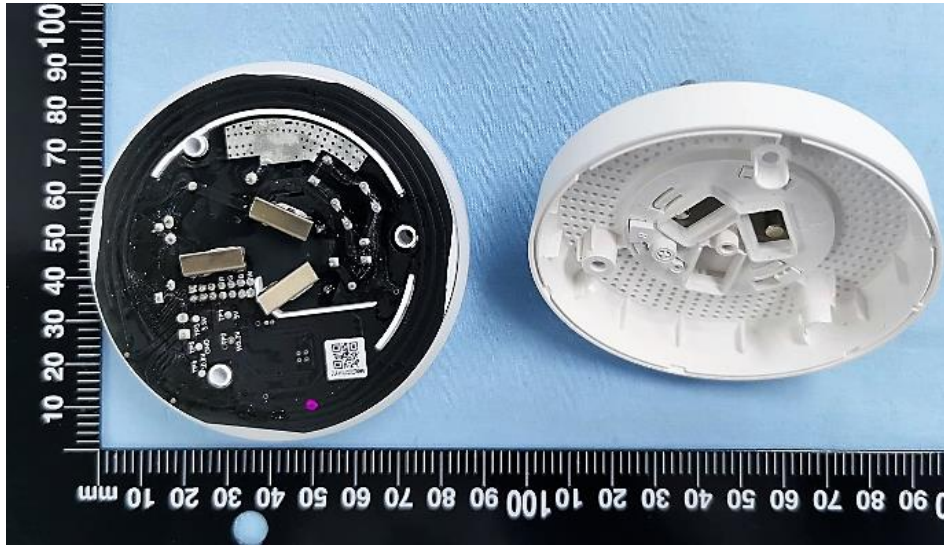

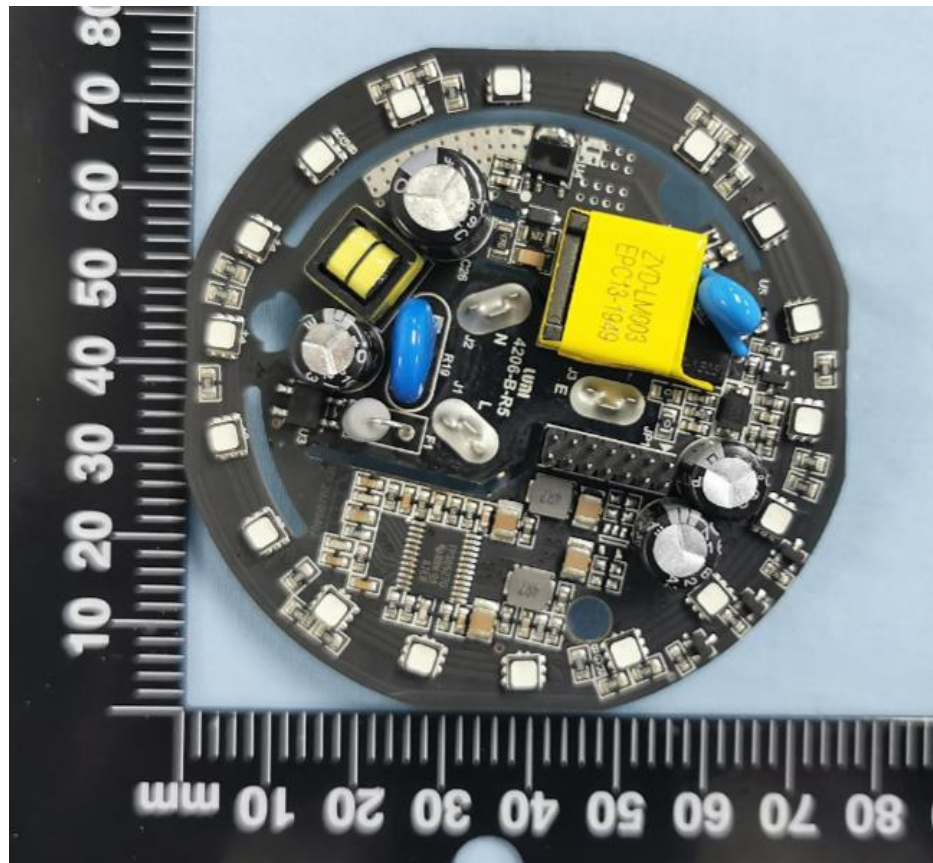
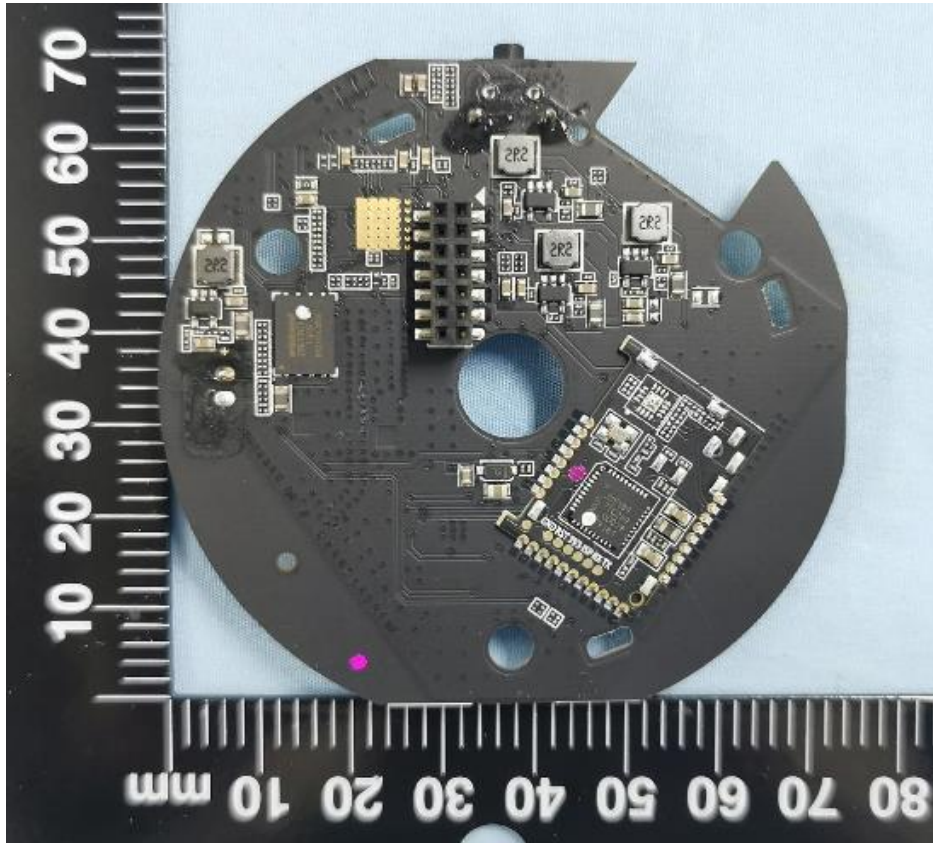

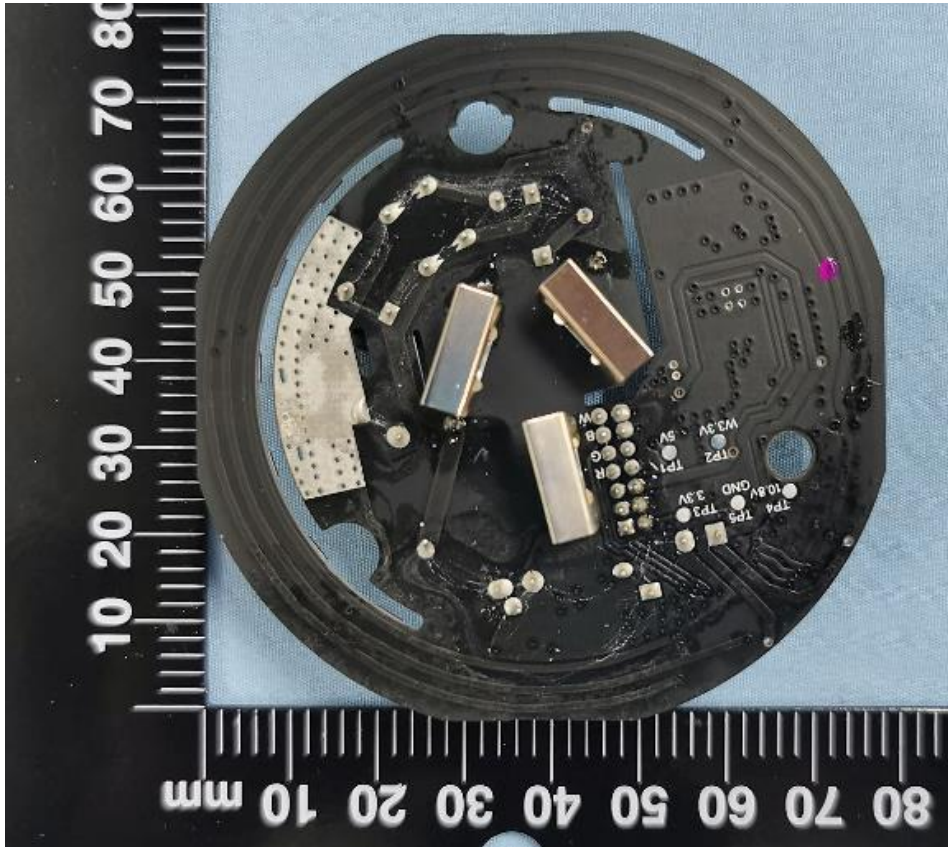

***** END *****