



# TEST REPORT

**Reference No.**..... : WTX20X09067942W-5

**Manufacturer** ..... : Lumi United Technology Co., Ltd.

**Address** ..... : 8th Floor, JinQi Wisdom Valley, No.1 Tangling Road, Liuxian Ave, Taoyuan Residential District, Nanshan District, Shenzhen.China

**Product** ..... : Hub M2

**Test Model** ..... : HM2-G01

**Standards** ..... : **ETSI EN 301 489-1 V2.2.3 (2019-11)**  
**ETSI EN 301 489-17 V3.2.4 (2020-09)**

**Date of Receipt sample** .... : Sept.18, 2020

**Date of Test**..... : Sept.18, 2020 to Oct.27, 2020

**Date of Issue** ..... : Oct.27, 2020

**Test Result**..... : **Pass**

**Remarks:**

The results shown in this test report refer only to the sample(s) tested, this test report cannot be reproduced, except in full, without prior written permission of the company. The report would be invalid without specific stamp of test institute and the signatures of compiler and approver.

**Prepared By:**

**Waltek Testing Group (Shenzhen) Co., Ltd.**

Address: 1/F., Room 101, Building 1, Hongwei Industrial Park, Liuxian 2nd Road, Block 70 Bao'an District, Shenzhen, Guangdong, China

Tel.: +86-755-33663308

Fax.: +86-755-33663309

Tested by:

Reviewed By:

Approved & Authorized By:

*Jack Huang*

*Lion Cai*

*Silin Chen*

Jack Huang/ Project Engineer

Lion Cai / RF Manager

Silin Chen / Manager





## **TABLE OF CONTENTS**

<b>1. GENERAL INFORMATION</b> .....	<b>5</b>
1.2 TEST STANDARDS.....	7
1.3 TEST METHODOLOGY .....	7
1.4 TEST FACILITY .....	7
1.5 EUT SETUP AND OPERATION MODE .....	8
1.6 PERFORMANCE CRITERIA FOR EMS .....	9
1.7 MEASUREMENT UNCERTAINTY .....	10
1.8 TEST EQUIPMENT LIST AND DETAILS .....	11
<b>2. SUMMARY OF TEST RESULTS</b> .....	<b>13</b>
<b>3. CONDUCTED EMISSIONS</b> .....	<b>14</b>
3.1 TEST PROCEDURE.....	14
3.2 BASIC TEST SETUP BLOCK DIAGRAM.....	14
3.3 ENVIRONMENTAL CONDITIONS .....	14
3.4 CONDUCTED EMISSIONS TEST DATA.....	14
<b>4. RADIATED EMISSIONS</b> .....	<b>24</b>
4.1 TEST PROCEDURE.....	24
4.2 CORRECTED AMPLITUDE & MARGIN CALCULATION.....	24
4.3 ENVIRONMENTAL CONDITIONS .....	24
4.4 SUMMARY OF TEST RESULTS/PLOTS .....	25
<b>5. HARMONIC CURRENT EMISSIONS</b> .....	<b>35</b>
5.1 TEST PROCEDURE.....	35
5.2 TEST SETUP BLOCK DIAGRAM.....	35
5.3 TEST STANDARDS .....	35
5.4 ENVIRONMENTAL CONDITIONS.....	35
5.5 HARMONIC CURRENT EMISSIONS TEST DATA.....	35
<b>6. VOLTAGE FLUCTUATION AND FLICKER</b> .....	<b>40</b>
6.1 TEST PROCEDURE.....	40
6.2 TEST SETUP BLOCK DIAGRAM.....	40
6.3 TEST STANDARDS .....	40
6.4 ENVIRONMENTAL CONDITIONS.....	40
6.5 VOLTAGE FLUCTUATION AND FLICKER TEST DATA.....	40
<b>7. ELECTROSTATIC DISCHARGE (ESD)</b> .....	<b>42</b>
7.1 TEST PROCEDURE.....	42
7.2 TEST SETUP BLOCK DIAGRAM.....	42
7.3 TEST PERFORMANCE .....	42
7.4 ENVIRONMENTAL CONDITIONS.....	42
7.5 ELECTROSTATIC DISCHARGE IMMUNITY TEST DATA .....	42
<b>8. RADIO FREQUENCY ELECTROMAGNETIC FIELD (R/S)</b> .....	<b>44</b>
8.1 TEST PROCEDURE.....	44
8.2 TEST SETUP BLOCK DIAGRAM.....	44
8.3 TEST PERFORMANCE .....	44
8.4 ENVIRONMENTAL CONDITIONS.....	44
8.5 CONTINUOUS RADIATED DISTURBANCES TEST DATA.....	44
<b>9. FAST TRANSIENTS, COMMON MODE (EFT)</b> .....	<b>46</b>
9.1 TEST PROCEDURE.....	46
9.2 TEST SETUP BLOCK DIAGRAM.....	46
9.3 TEST PERFORMANCE .....	46
9.4 ENVIRONMENTAL CONDITIONS.....	46
9.5 ELECTRICAL FAST TRANSIENTS TEST DATA .....	46
<b>10. SURGES</b> .....	<b>48</b>
10.1 TEST PROCEDURE.....	48



10.2 TEST SETUP BLOCK DIAGRAM.....	48
10.3 TEST PERFORMANCE .....	48
10.4 ENVIRONMENTAL CONDITIONS.....	48
10.5 SURGE TEST DATA.....	48
<b>11. RADIO FREQUENCY, COMMON MODE (C/S) .....</b>	<b>50</b>
11.1 TEST PROCEDURE.....	50
11.2 TEST SETUP BLOCK DIAGRAM.....	50
11.3 TEST PERFORMANCE .....	50
11.4 ENVIRONMENTAL CONDITIONS.....	50
11.5 CONTINUOUS CONDUCTED DISTURBANCES TEST DATA .....	50
<b>12. VOLTAGE DIPS AND INTERRUPTIONS.....</b>	<b>52</b>
12.1 TEST PROCEDURE.....	52
12.2 TEST SETUP BLOCK DIAGRAM.....	52
12.3 TEST PERFORMANCE .....	52
12.4 ENVIRONMENTAL CONDITIONS.....	52
12.5 VOLTAGE DIPS AND INTERRUPTIONS TEST DATA .....	52
<b>EXHIBIT 1 - EUT PHOTOGRAPHS.....</b>	<b>53</b>
<b>EXHIBIT 2 - TEST SETUP PHOTOGRAPHS.....</b>	<b>54</b>



# WALTEK



## Report version

Version No.	Date of issue	Description
Rev.00	Oct.27, 2020	Original
/	/	/



# WALTEK



## 1. GENERAL INFORMATION

---

### 1.1 Product Description for Equipment Under Test (EUT)

#### Client Information

Manufacturer: Lumi United Technology Co., Ltd.  
Address of manufacturer: 8th Floor, JinQi Wisdom Valley, No.1 Tangling Road, Liuxian Ave, Taoyuan Residential District, Nanshan District, Shenzhen .China

General Description of EUT	
Product Name:	Hub M2
Trade Name:	Aqara
Model No.:	HM2-G01
Adding Model(s):	/
Rated Voltage:	DC 5V, 1A Or DC 5V, 2A
Battery Capacity:	/
Power Adapter:	/
Software Version:	V1.1.0
Hardware Version:	3.0.6_0005.0515
<i>Note: The test data is gathered from a production sample, provided by the manufacturer.</i>	

# WALTEK



<b>Technical Characteristics of EUT</b>	
<b>Wi-Fi(2.4G)</b>	
Support Standards:	802.11b, 802.11g, 802.11n-HT20/40
Frequency Range:	2412-2472MHz for 802.11b/g/n(HT20) 2422-2462MHz for 802.11b/g/n(HT40)
Max.RF Output Power:	Antenna A: 18.53dBm (EIRP) Antenna B: 18.42dBm (EIRP) MIMO: 17.44dBm (EIRP)
Type of Modulation:	DBPSK,BPSK,DQPSK,QPSK,16QAM,64QAM
Data Rate:	1-11Mbps, 6-54Mbps, up to 150Mbps
Quantity of Channels	13 for 802.11b/g/n(HT20) 9 for 802.11b/g/n(HT40)
Channel Separation:	5MHz
Type of Antenna:	PCB Antenna
Antenna Gain:	2.0dBi
<b>Bluetooth</b>	
Bluetooth Version:	Bluetooth V5.0(Only BLE)
Frequency Range:	2402-2480MHz
Max.RF Output Power:	1M: 5.50dBm (EIRP) 2M: 5.48dBm (EIRP)
Type of Modulation:	GFSK
Data Rate:	1Mbps
Quantity of Channels	40
Channel Separation:	2MHz
Type of Antenna:	PCB Antenna
Antenna Gain:	0dBi
<b>ZigBee</b>	
Support Standards:	ZigBee
Frequency Range:	2405MHz-2480MHz
Max.RF Output Power:	8.67dBm (EIRP)
Modulation:	OQPSK
Type of Antenna:	PCB Antenna
Antenna Gain:	0dBi



## 1.2 Test Standards

The tests were performed according to following standards:

**ETSI EN 301 489-1 V2.2.3 (2019-11):** Electromagnetic Compatibility (EMC) standard for radio equipment and services; Part 1: Common technical requirements; Harmonised Standard for Electromagnetic Compatibility.

**ETSI EN 301 489-17 V3.2.4 (2020-09):** ElectroMagnetic Compatibility (EMC) standard for radio equipment and services; Part 17: Specific conditions for Broadband Data Transmission Systems; Harmonised Standard for ElectroMagnetic Compatibility

**Maintenance of compliance** is the responsibility of the manufacturer. Any modification of the product maybe which result in lowering the emission/immunity should be checked to ensure compliance has been maintained.

## 1.3 Test Methodology

All measurements contained in this report were conducted with the standard ETSI EN 301489-1, Electromagnetic compatibility and Radio spectrum Matters (ERM); Electromagnetic Compatibility (EMC) standard for radio equipment and services; Part 1: Common technical requirements.

## 1.4 Test Facility

### **FCC – Registration No.: 125990**

Waltek Testing Group (Shenzhen) Co., Ltd. Laboratory has been recognized to perform compliance testing on equipment subject to the Commissions Declaration Of Conformity (DOC). The Designation Number is CN5010, and Test Firm Registration Number is 125990.

### **Industry Canada (IC) Registration No.: 11464A**

The 3m Semi-anechoic chamber of Waltek Testing Group (Shenzhen) Co., Ltd. has been registered by Certification and Engineering Bureau of Industry Canada for radio equipment testing with Registration No.: 11464A.



## 1.5 EUT Setup and Operation Mode

The equipment under test (EUT) was configured to measure its highest possible emission/immunity level. The test modes were adapted according to the operation manual for use, more detailed description as follows:

Test Mode List		
Test Mode	Description	Remark
TM1	Normal Working	Connect to the Adapter AC230V 50Hz ,APP Working
TM2	Bluetooth	Connect to the Adapter AC230V 50Hz ,APP Working
TM3	WIFI	Connect to the Adapter AC230V 50Hz ,APP Working
TM4	ZIGBEE	Connect to the Adapter AC230V 50Hz ,APP Working
TM5	BT (2.4G)	TR, CR, TT, CT for EMS testing
TM6	WIFI (2.4G)	TR, CR, TT, CT for EMS testing
TM7	ZIGBEE (2.4G)	TR, CR, TT, CT for EMS testing

EUT Cable List and Details			
Cable Description	Length (m)	Shielded/Unshielded	With / Without Ferrite
USB Cable	1.54	Unshielded	Without Ferrite

Special Cable List and Details			
Cable Description	Length (m)	Shielded/Unshielded	With / Without Ferrite
/	/	/	/

Auxiliary Equipment List and Details			
Description	Manufacturer	Model	Serial Number
Wireless switch T1	Lumi	WXKG13LM	/
Mobile phone	HUAWEI	VOG-AL00	/
Notebook	Lenovo	E445	EB12648265
Adapter	HONOTO	ADS-5RE-06 05050EPCN	/





## 1.6 Performance Criteria for EMS

### ➤ EN 301 489-17, The performance criteria are:

- performance criteria A for immunity tests with phenomena of a continuous nature;
- performance criteria B for immunity tests with phenomena of a transient nature;
- performance criteria C for immunity tests with power interruptions exceeding a certain time.

The equipment shall meet the minimum performance criteria as specified in the following clauses.

Table 1: Performance criteria

Criteria	During test	After test
A	Shall operate as intended. (see note 1). Shall be no loss of function. Shall be no unintentional transmissions.	Shall operate as intended. Shall be no degradation of performance (see note 3). Shall be no loss of function. Shall be no loss of stored data or user programmable functions.
B	May show loss of function (one or more). May show degradation of performance (see note 2). Shall be no unintentional transmissions.	Functions shall be self-recoverable. Shall operate as intended after recovering. Shall be no degradation of performance (see note 3). Shall be no loss of stored data or user programmable functions.
C	May be loss of function (one or more).	Functions shall be recoverable by the operator. Shall operate as intended after recovering. Shall be no degradation of performance (see note 3).

NOTE 1: Operate as intended during the test allows a level of degradation not below a minimum performance level specified by the manufacturer for the use of the apparatus as intended. In some cases the specified minimum performance level may be replaced by a permissible degradation of performance. If the minimum performance level or the permissible performance degradation is not specified by the manufacturer then either of these may be derived from the product description and documentation (including leaflets and advertising) and what the user may reasonably expect from the apparatus if used as intended.

NOTE 2: Degradation of performance during the test is understood as a degradation to a level not below a minimum performance level specified by the manufacturer for the use of the apparatus as intended. In some cases the specified minimum performance level may be replaced by a permissible degradation of performance. If the minimum performance level or the permissible performance degradation is not specified by the manufacturer then either of these may be derived from the product description and documentation (including leaflets and advertising) and what the user may reasonably expect from the apparatus if used as intended.

NOTE 3: No degradation of performance after the test is understood as no degradation below a minimum performance level specified by the manufacturer for the use of the apparatus as intended. In some cases the specified minimum performance level may be replaced by a permissible degradation of performance. After the test no change of actual operating data or user retrievable data is allowed. If the minimum performance level or the permissible performance degradation is not specified by the manufacturer then either of these may be derived from the product description and documentation (including leaflets and advertising) and what the user may reasonably expect from the apparatus if used as intended.



## 1.7 Measurement Uncertainty

Measurement uncertainty	
Parameter	Uncertainty
Uncertainty for Radiated Emission in 3m chamber	@30-200MHz $\pm 4.52\text{dB}$ @0.2-1GHz $\pm 5.56\text{dB}$ @1-6GHz $\pm 3.84\text{dB}$ @6-18GHz $\pm 3.92\text{dB}$
Uncertainty for Conducted Emission	@9-150kHz $\pm 3.74\text{dB}$ @0.15-30MHz $\pm 3.34\text{dB}$
Uncertainty for Harmonic test	3.26%
Uncertainty for Flicker test	4.76%
Uncertainty for RS test	21%, k=2
Uncertainty for CS test	29%, k=2
Uncertainty for ESD test	The immunity measurement system uncertainty is within standard requirement and is based on a standard uncertainty multiplied by a coverage factor k=2, providing a level of confidence of approximately 95%.
Uncertainty for EFT test	
Uncertainty for Surges test	
Uncertainty for Voltage Dips, Voltage Variations and Short Interruptions Test	
Uncertainty for PFMF test	

# WALTEK



## 1.8 Test Equipment List and Details

Description	Manufacturer	Model	Serial Number	Cal Date	Due Date
Spectrum Analyzer	Rohde & Schwarz	FSP	836079/035	2020-04-28	2021-04-27
EMI Test Receiver	Rohde & Schwarz	ESVB	825471/005	2020-04-28	2021-04-27
Amplifier	Agilent	8447F	3113A06717	2020-04-28	2021-04-27
Amplifier	C&D	PAP-1G18	2002	2020-04-28	2021-04-27
Broadband Antenna	Schwarz beck	VULB9163	9163-333	2019-05-05	2021-05-04
Horn Antenna	ETS	3117	00086197	2019-05-05	2021-05-04
Loop Antenna	Schwarz beck	FMZB 1516	9773	2019-05-05	2021-05-04
EMI Test Receiver	Rohde & Schwarz	ESPI	101611	2020-04-28	2021-04-27
Pulse Limiter	Rohde & Schwarz	ESH3-Z2	100911	2020-04-28	2021-04-27
AC LISN	Schwarz beck	NSLK8126	8126-224	2020-04-28	2021-04-27
DC LISN	Schwarz beck	NNBM8126D	279	2020-04-28	2021-04-27
8-WIRE LISN	Schwarz beck	8158	CAT3-8158-0059	2020-04-28	2021-04-27
8-WIRE LISN	Schwarz beck	8158	CAT5-8158-0117	2020-04-28	2021-04-27
Digital Power Analyzer	California Instrument	PACS-1	72831	2020-04-28	2021-04-27
Power Source	California Instrument	5001iX	25965	2020-04-28	2021-04-27
ESD Generator	LIOGCEL	ESD-203B	0170901	2020-04-28	2021-04-27
Signal Generator	Rohde & Schwarz	SMT03	100059	2020-04-28	2021-04-27
Voltage Probe	Rohde & Schwarz	URV5-Z2	100013	2020-04-28	2021-04-27
Power Amplifier	AR	150W1000	300999	2020-04-28	2021-04-27
Power Amplifier	AR	25S1G4AM1	305993	2020-04-28	2021-04-27
Transient 2000	EMC PARTNER	TRA2000	863	2020-04-28	2021-04-27
CS Immunity Tester	SCHAFFNER	NSG2070	1123	2020-04-28	2021-04-27
CDN	Luthi	CDNL-801	2655	2020-04-28	2021-04-27
Attenuator	EMCI	MA-5100/6BF2	1009	2020-04-28	2021-04-27
EMC PRO	KEYTEK	EMCPro	0509124	2020-04-28	2021-04-27
Coil	KEYTEK	F-1000-4-8	0533	2020-04-28	2021-04-27
Anechoic chamber	Albatross Projects	MCDC	----	2020-04-28	2021-04-27
CS Generator	MARCONI	2024	112260/042	2020-04-28	2021-04-27
Attenuator	FRANKONIA	75-A-FFN-06	1001698	2020-04-28	2021-04-27
CDN	FRANKONIA	CDN M2+M3	A3027019	2020-04-28	2021-04-27
Signal Generator	HP	8688B	3438A00604	2020-04-28	2021-04-27
Power Meter	KEITHLEY	3500	1162591	2020-04-28	2021-04-27
Power Meter	KEITHLEY	3500	1121428	2020-04-28	2021-04-27
RF Power Amplifier	MicoTop	MPA-80-1000-250	MPA1906239	2020-04-28	2021-04-27
RF Power Amplifier	MicoTop	MPA-80-1000-100	MPA1906238	2020-04-28	2021-04-27
Antenna	SCHWARZBECK	STLP 9129	9129 114	N/A	N/A



Software List			
Description	Manufacturer	Model	Version
EMI Test Software (Radiated Emission)*	Farad	EZ-EMC	RA-03A1
EMI Test Software (Conducted Emission)*	Farad	EZ-EMC	RA-03A1

\*Remark: indicates software version used in the compliance certification testing



# WALTEK



## 2. SUMMARY OF TEST RESULTS

Standards	Reference	Description of Test Item	Result
ETSI EN 301 489-1	8.2	Radiated Emissions	Pass
	8.3	Conducted Emissions for DC Power Port	N/A
	8.4	Conducted Emissions for AC Power Port	Pass
	8.5	Harmonic Current Emissions	Pass
	8.6	Voltage Fluctuations and Flicker	Pass
	8.7	Telecommunication Ports	N/A
	9.2	Radio Frequency Electromagnetic Field	Pass
	9.3	Electrostatic Discharge	Pass
	9.4	Fast Transients, Common Mode	Pass
	9.5	Radio Frequency, Common Mode	Pass
	9.6	Transient and Surges in the Vehicular Environment	N/A
	9.7	Voltage Dips and Interruptions	Pass
	9.8	Surges	Pass

Pass: The EUT complies with the essential requirements in the standard.  
 Fail: The EUT does not comply with the essential requirements in the standard.  
 N/A: Not applicable.

# WALTEK



### 3. Conducted Emissions

#### 3.1 Test Procedure

Test is conducting under the description of EN55032 Information technology equipment - Radio disturbance characteristics - Limits and methods of measurement.

#### 3.2 Basic Test Setup Block Diagram

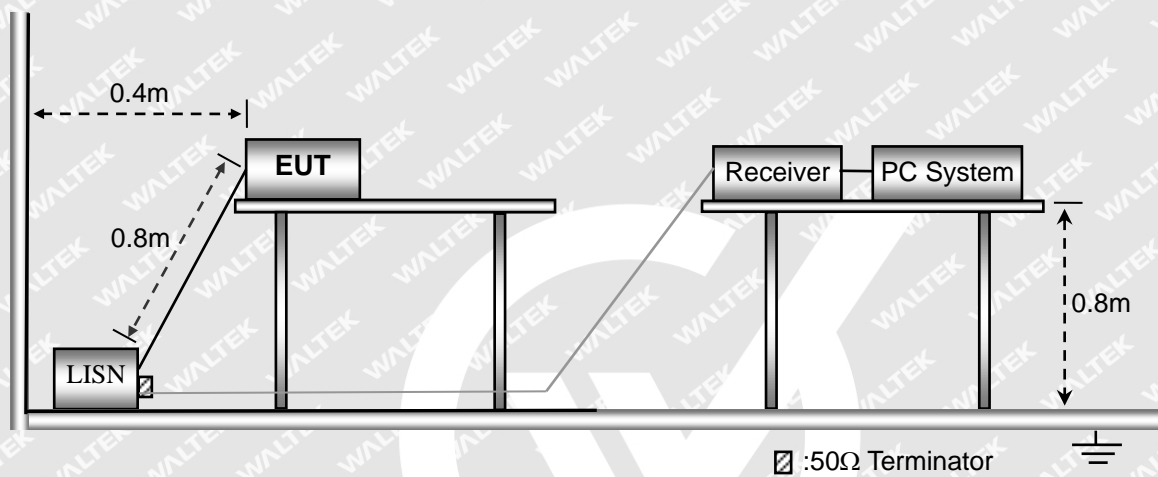

#### 3.3 Environmental Conditions

Temperature:	23.5 °C
Relative Humidity:	55 %
ATM Pressure:	1015 mbar

#### 3.4 Conducted Emissions Test Data

Note: Only show the worst case in the test report



Test mode:	TM1	Polarity:	Neutral
------------	-----	-----------	---------

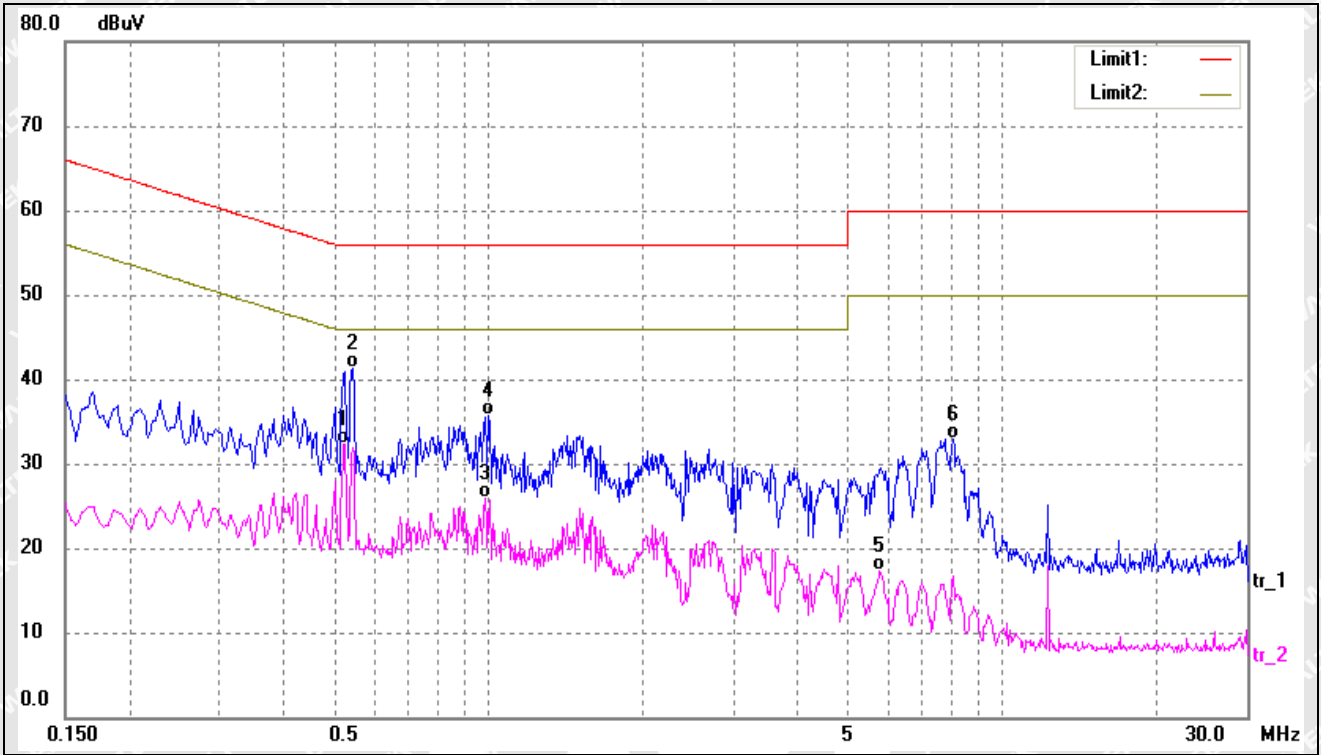

No.	Frequency (MHz)	Reading (dBuV)	Correct (dB/m)	Result (dBuV)	Limit (dBuV)	Margin (dB)	Detector
1*	0.5220	22.16	10.22	32.38	46.00	-13.62	AVG
2	0.5460	31.03	10.21	41.24	56.00	-14.76	QP
3	0.9860	15.66	10.20	25.86	46.00	-20.14	AVG
4	1.0020	25.42	10.20	35.62	56.00	-20.38	QP
5	5.8020	7.01	10.23	17.24	50.00	-32.76	AVG
6	8.0500	22.72	10.27	32.99	60.00	-27.01	QP



Test mode:	TM1	Polarity:	Line
------------	-----	-----------	------

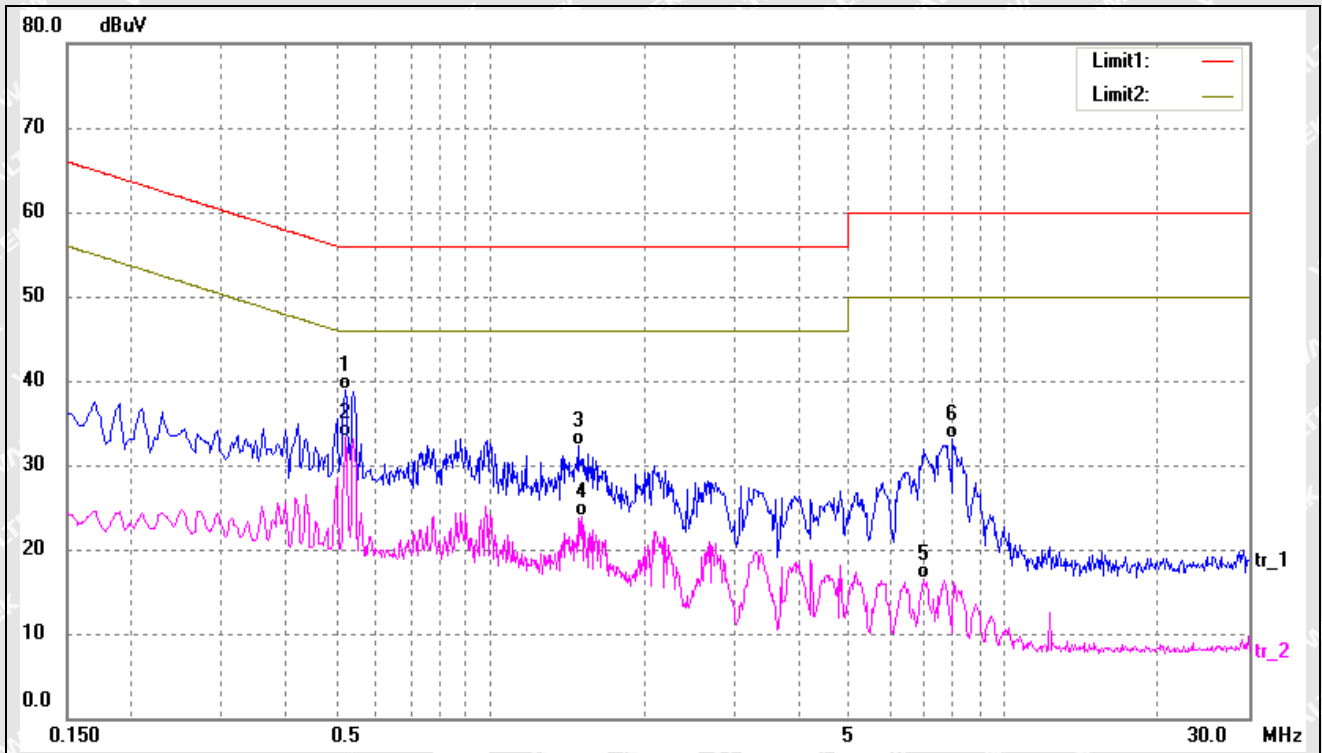

No.	Frequency (MHz)	Reading (dBuV)	Correct (dB/m)	Result (dBuV)	Limit (dBuV)	Margin (dB)	Detector
1	0.5220	28.62	10.22	38.84	56.00	-17.16	QP
2*	0.5220	23.00	10.22	33.22	46.00	-12.78	AVG
3	1.4819	21.98	10.23	32.21	56.00	-23.79	QP
4	1.5060	13.63	10.23	23.86	46.00	-22.14	AVG
5	6.9780	6.18	10.25	16.43	50.00	-33.57	AVG
6	7.9580	22.77	10.27	33.04	60.00	-26.96	QP





Test mode:	TM2	Polarity:	Neutral
------------	-----	-----------	---------

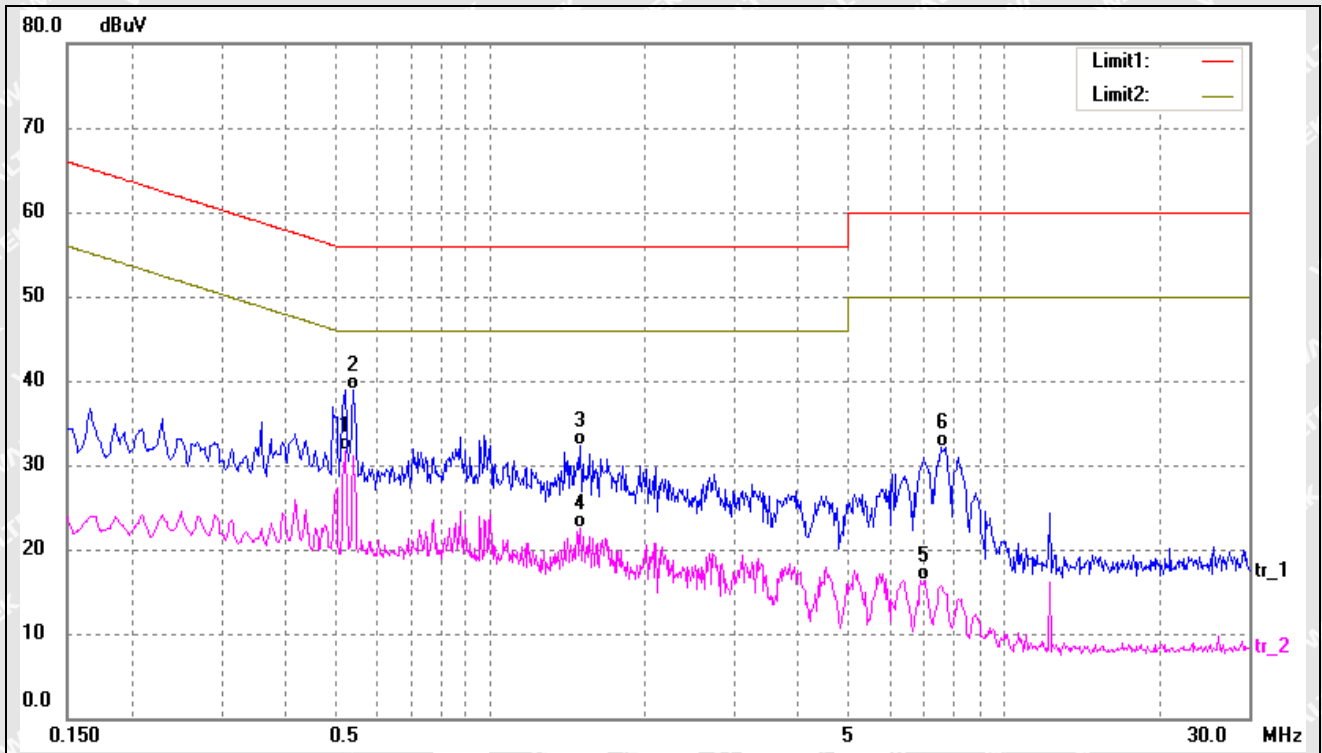

No.	Frequency (MHz)	Reading (dBuV)	Correct (dB/m)	Result (dBuV)	Limit (dBuV)	Margin (dB)	Detector
1*	0.5220	21.56	10.22	31.78	46.00	-14.22	AVG
2	0.5420	28.77	10.21	38.98	56.00	-17.02	QP
3	1.5020	22.11	10.23	32.34	56.00	-23.66	QP
4	1.5020	12.35	10.23	22.58	46.00	-23.42	AVG
5	7.0260	6.03	10.25	16.28	50.00	-33.72	AVG
6	7.7100	21.88	10.26	32.14	60.00	-27.86	QP



Test mode:	TM2	Polarity:	Line
------------	-----	-----------	------

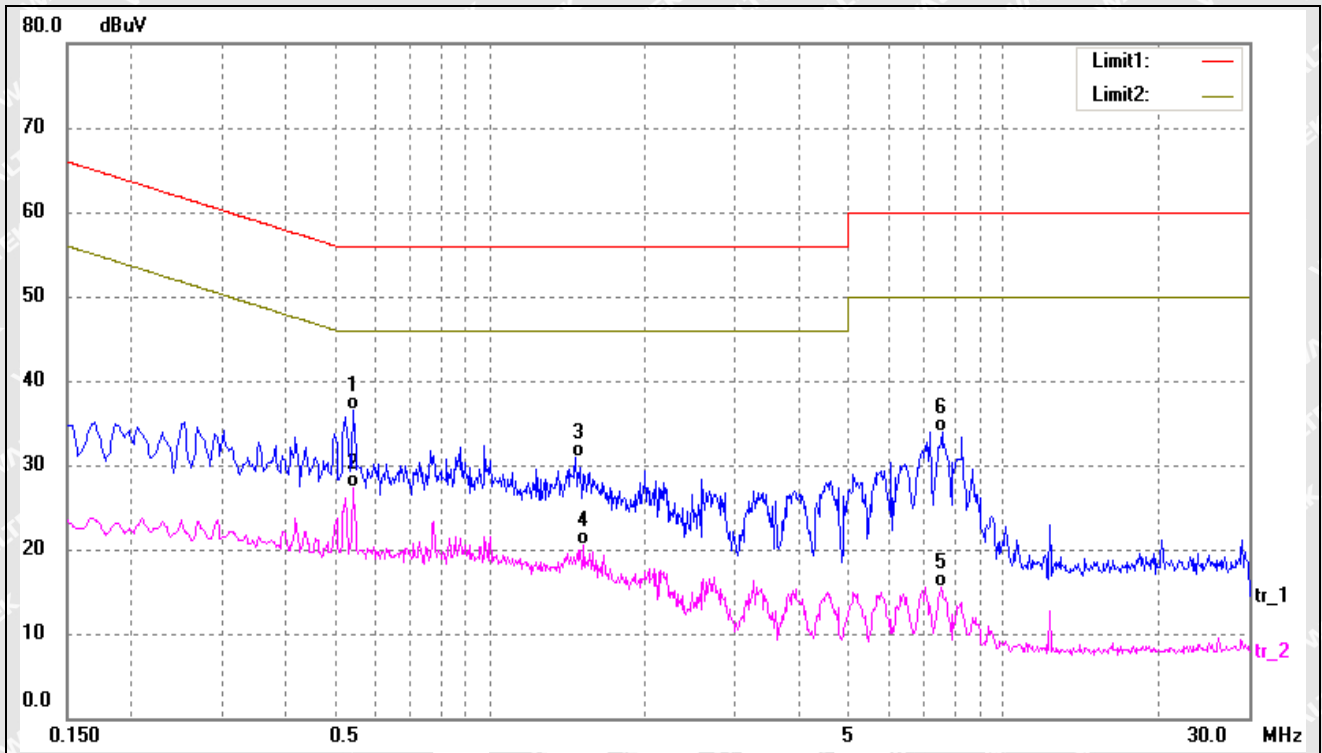

No.	Frequency (MHz)	Reading (dBuV)	Correct (dB/m)	Result (dBuV)	Limit (dBuV)	Margin (dB)	Detector
1	0.5420	26.30	10.21	36.51	56.00	-19.49	QP
2*	0.5420	17.08	10.21	27.29	46.00	-18.71	AVG
3	1.4660	20.75	10.23	30.98	56.00	-25.02	QP
4	1.5220	10.22	10.23	20.45	46.00	-25.55	AVG
5	7.5460	5.30	10.25	15.55	50.00	-34.45	AVG
6	7.6060	23.71	10.26	33.97	60.00	-26.03	QP



Test mode:	TM3	Polarity:	Neutral
------------	-----	-----------	---------

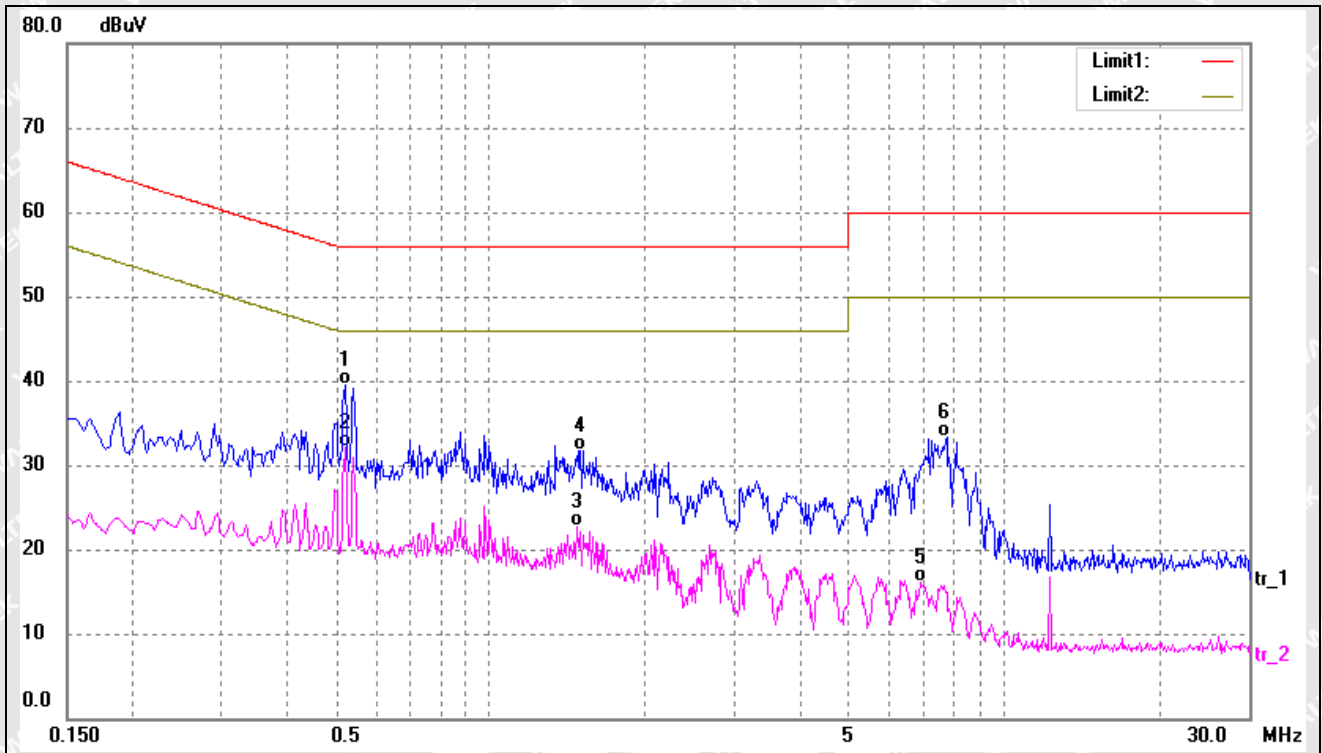

No.	Frequency (MHz)	Reading (dBuV)	Correct (dB/m)	Result (dBuV)	Limit (dBuV)	Margin (dB)	Detector
1	0.5220	29.26	10.22	39.48	56.00	-16.52	QP
2*	0.5220	21.87	10.22	32.09	46.00	-13.91	AVG
3	1.4780	12.38	10.23	22.61	46.00	-23.39	AVG
4	1.4980	21.57	10.23	31.80	56.00	-24.20	QP
5	6.8940	5.90	10.25	16.15	50.00	-33.85	AVG
6	7.7500	23.09	10.26	33.35	60.00	-26.65	QP



Test mode:	TM3	Polarity:	Line
------------	-----	-----------	------

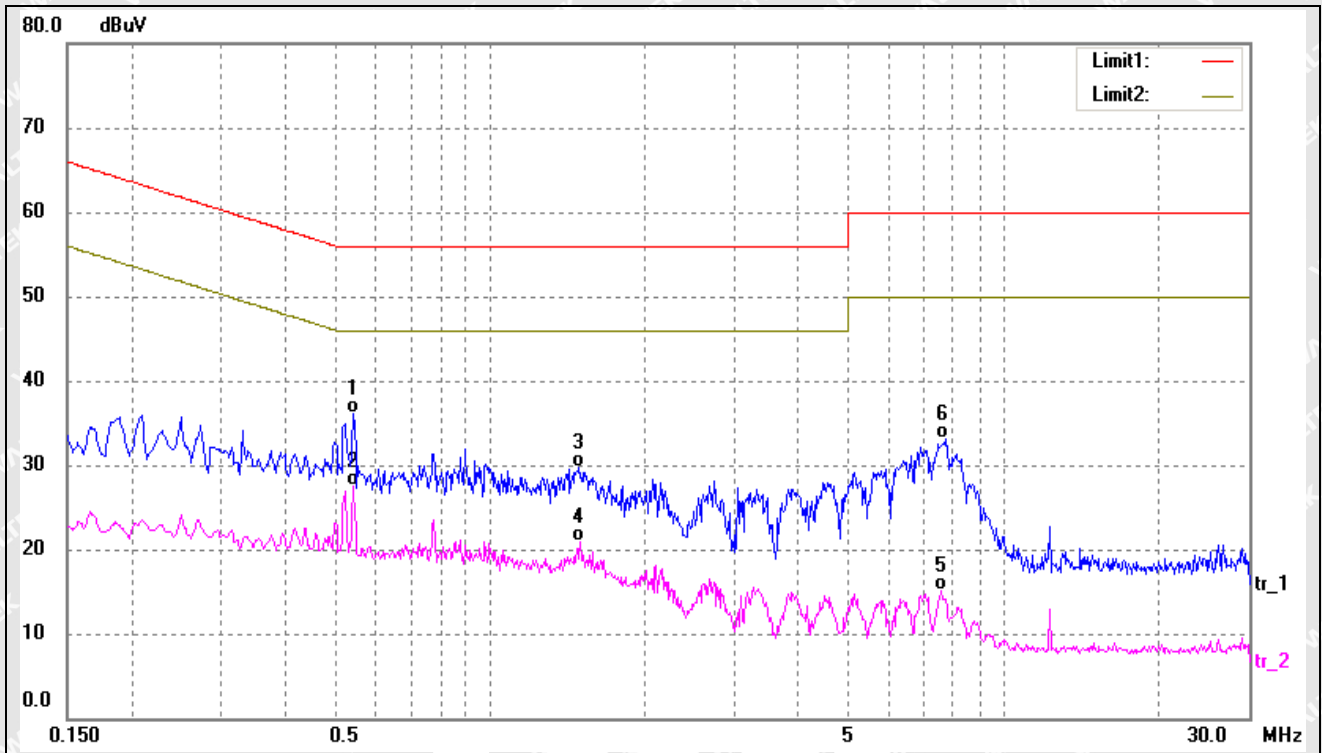

No.	Frequency (MHz)	Reading (dBuV)	Correct (dB/m)	Result (dBuV)	Limit (dBuV)	Margin (dB)	Detector
1	0.5420	25.88	10.21	36.09	56.00	-19.91	QP
2*	0.5420	17.27	10.21	27.48	46.00	-18.52	AVG
3	1.4940	19.40	10.23	29.63	56.00	-26.37	QP
4	1.4980	10.59	10.23	20.82	46.00	-25.18	AVG
5	7.5620	4.77	10.25	15.02	50.00	-34.98	AVG
6	7.7140	22.91	10.26	33.17	60.00	-26.83	QP



Test mode:	TM4	Polarity:	Neutral
------------	-----	-----------	---------

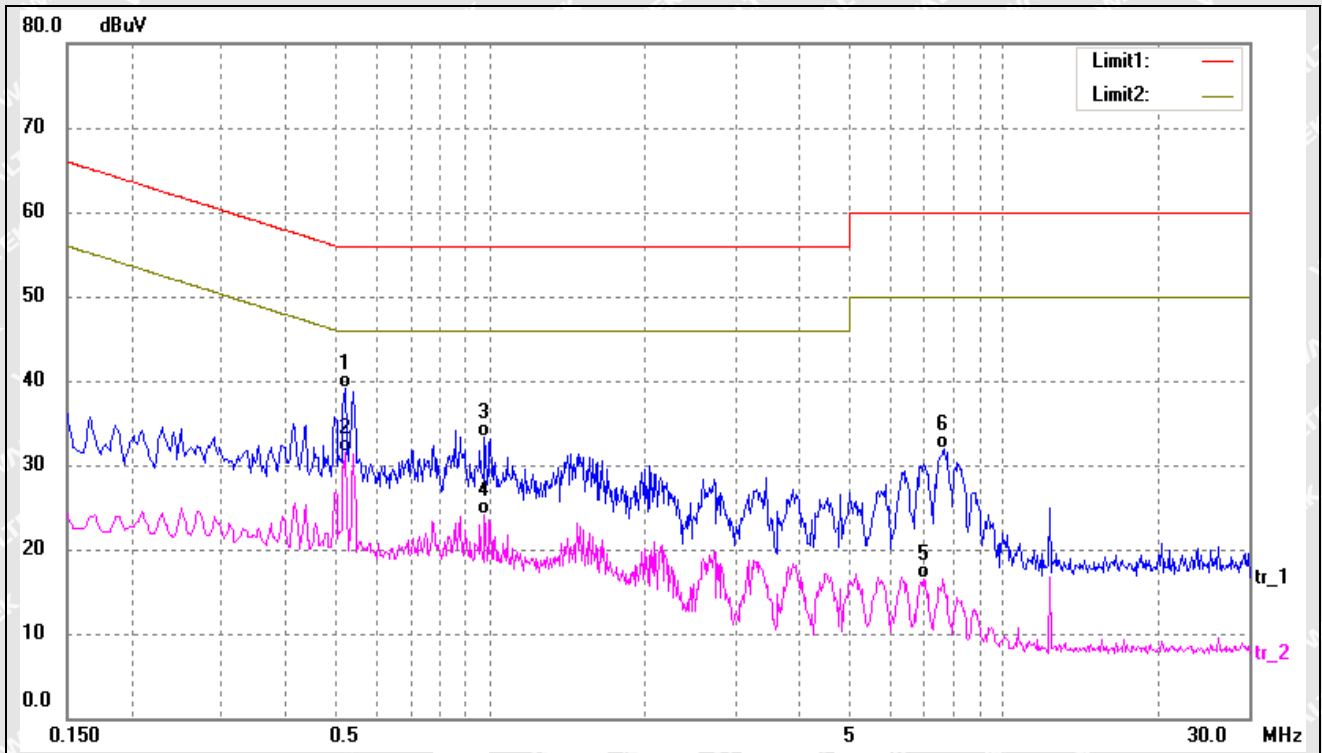

No.	Frequency (MHz)	Reading (dBuV)	Correct (dB/m)	Result (dBuV)	Limit (dBuV)	Margin (dB)	Detector
1	0.5220	28.96	10.22	39.18	56.00	-16.82	QP
2*	0.5220	21.36	10.22	31.58	46.00	-14.42	AVG
3	0.9780	23.05	10.20	33.25	56.00	-22.75	QP
4	0.9780	13.84	10.20	24.04	46.00	-21.96	AVG
5	6.9540	6.27	10.25	16.52	50.00	-33.48	AVG
6	7.6620	21.59	10.26	31.85	60.00	-28.15	QP



Test mode:	TM4	Polarity:	Line
------------	-----	-----------	------

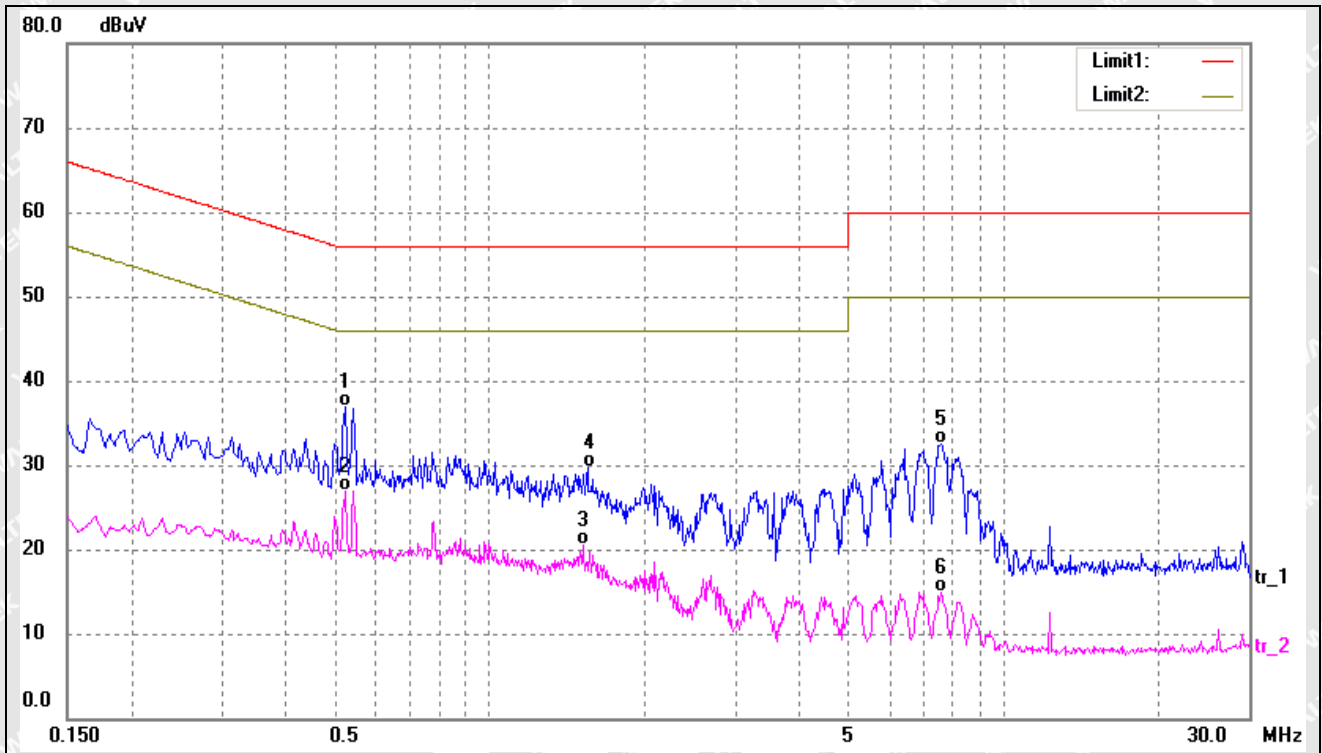

No.	Frequency (MHz)	Reading (dBuV)	Correct (dB/m)	Result (dBuV)	Limit (dBuV)	Margin (dB)	Detector
1	0.5220	26.65	10.22	36.87	56.00	-19.13	QP
2*	0.5220	16.74	10.22	26.96	46.00	-19.04	AVG
3	1.5180	10.33	10.23	20.56	46.00	-25.44	AVG
4	1.5460	19.46	10.24	29.70	56.00	-26.30	QP
5	7.5340	22.30	10.25	32.55	60.00	-27.45	QP
6	7.5340	4.73	10.25	14.98	50.00	-35.02	AVG



Test mode:	/	Polarity:	RJ45
------------	---	-----------	------

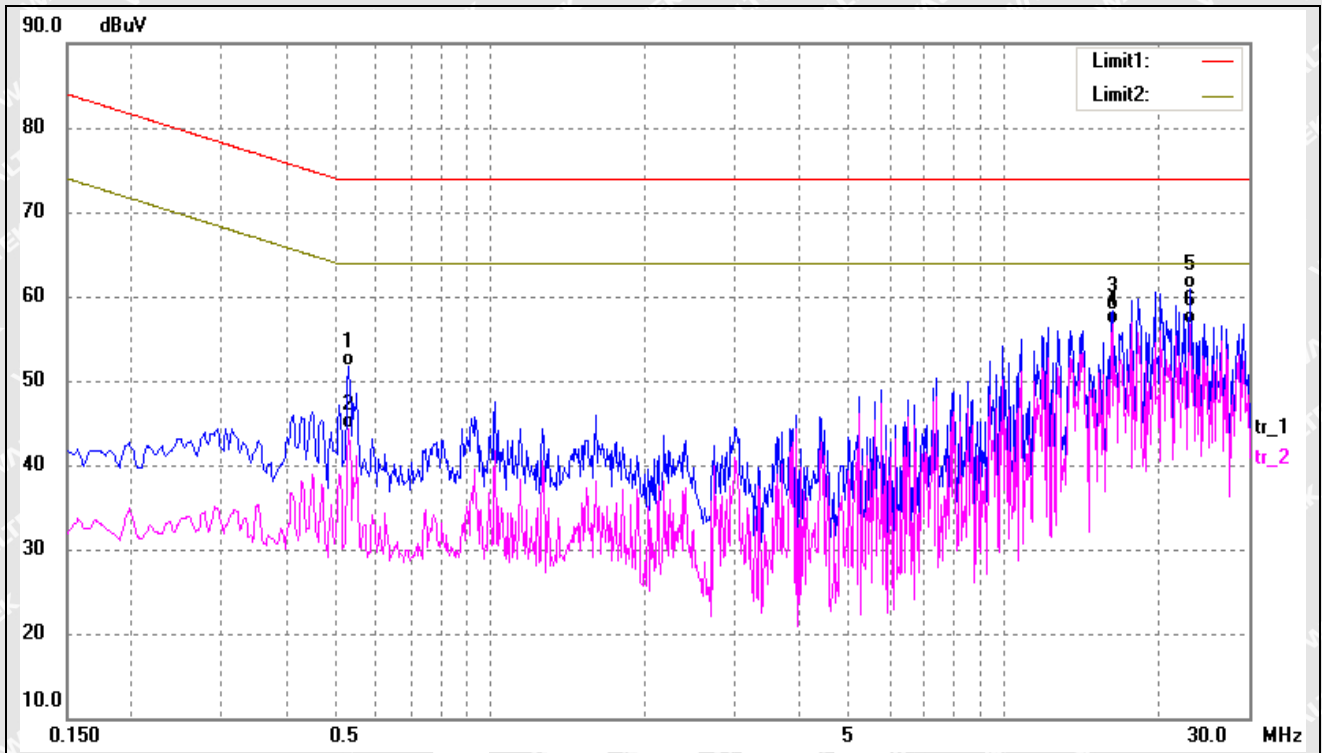

No.	Frequency (MHz)	Reading (dBuV)	Correct (dB/m)	Result (dBuV)	Limit (dBuV)	Margin (dB)	Detector
1	0.5300	31.96	19.72	51.68	74.00	-22.32	QP
2	0.5300	24.65	19.72	44.37	64.00	-19.63	AVG
3	16.2300	38.47	19.84	58.31	74.00	-15.69	QP
4*	16.2300	36.82	19.84	56.66	64.00	-7.34	AVG
5	23.1300	41.25	19.71	60.96	74.00	-13.04	QP
6	23.1300	36.95	19.71	56.66	64.00	-7.34	AVG



## 4. Radiated Emissions

### 4.1 Test Procedure

Test is conducting under the description of EN55032 Information technology equipment - Radio disturbance characteristics - Limits and methods of measurement.

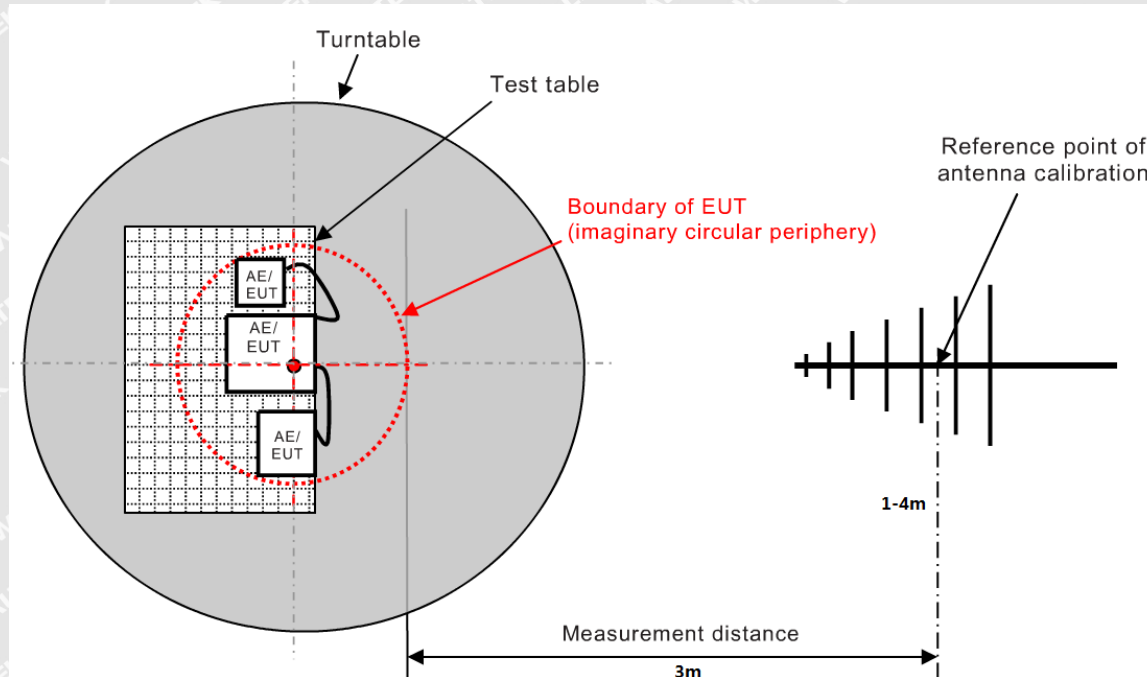

### 4.2 Corrected Amplitude & Margin Calculation

The Corrected Amplitude is calculated by adding the Antenna Factor and the Cable Factor, and subtracting the Amplifier Gain from the Amplitude reading. The basic equation is as follows:

$$\text{Corr. Ampl.} = \text{Indicated Reading} + \text{Antenna Factor} + \text{Cable Factor} - \text{Amplifier Gain}$$

The “**Margin**” column of the following data tables indicates the degree of compliance with the applicable limit. For example, a margin of  $-6\text{dB}\mu\text{V}$  means the emission is  $6\text{dB}\mu\text{V}$  below the maximum limit for Class B device. The equation for margin calculation is as follows:

$$\text{Margin} = \text{Corr. Ampl.} - \text{EN 301489 Class B Limit}$$

### 4.3 Environmental Conditions

Temperature:	23.5° C
Relative Humidity:	55%
ATM Pressure:	1011 mbar





#### 4.4 Summary of Test Results/Plots

Note: Only show the worst case in the test report

➤ 30MHz to 1GHz

Test mode:	TM1	Polarity:	Horizontal
------------	-----	-----------	------------

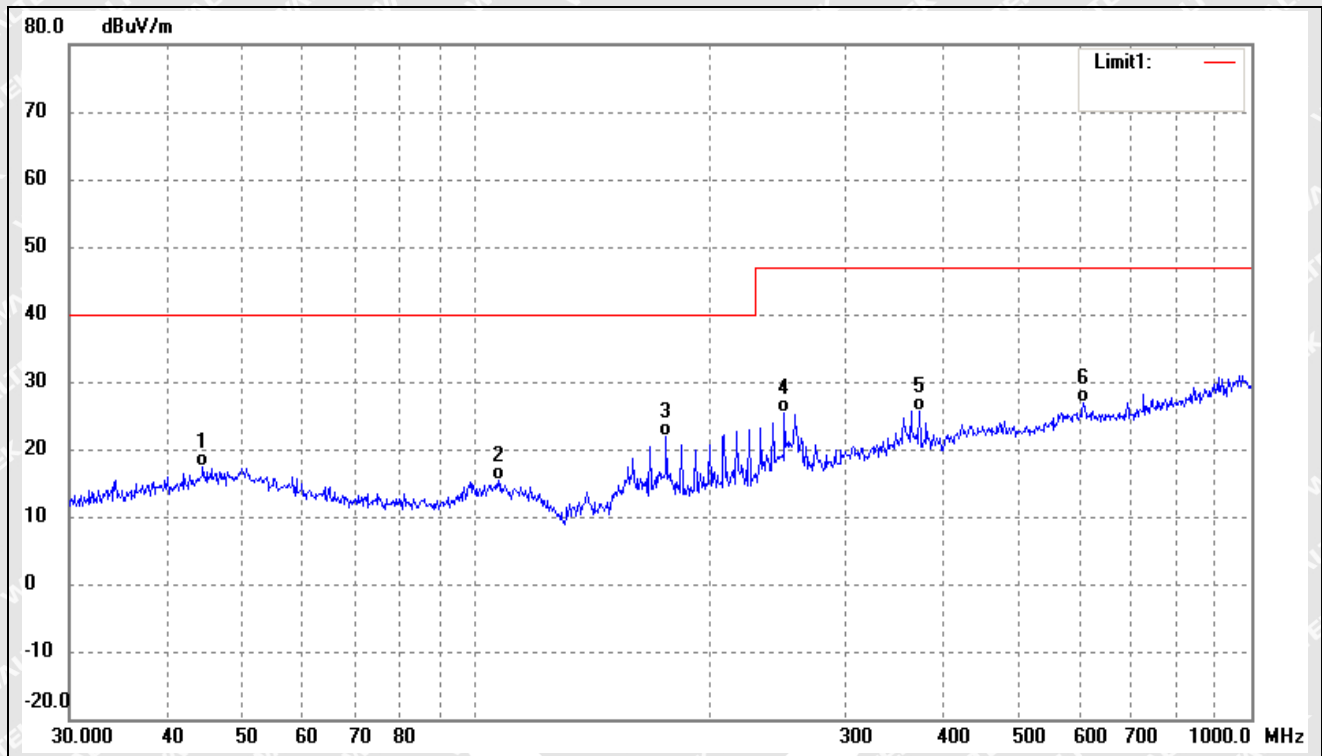

No.	Frequency (MHz)	Reading (dBuV/m)	Correct dB/m	Result (dBuV/m)	Limit (dBuV/m)	Margin (dB)	Degree ( )	Height (cm)	Remark
1	44.5868	27.99	-10.66	17.33	40.00	-22.67	-	-	QP
2	107.1337	27.55	-12.23	15.32	40.00	-24.68	-	-	QP
3	176.2686	35.38	-13.44	21.94	40.00	-18.06	-	-	QP
4	250.3012	34.57	-9.29	25.28	47.00	-21.72	-	-	QP
5	373.3112	31.38	-5.72	25.66	47.00	-21.34	-	-	QP
6	607.7867	29.17	-2.31	26.86	47.00	-20.14	-	-	QP



Test mode:	TM1	Polarity:	Vertical
------------	-----	-----------	----------

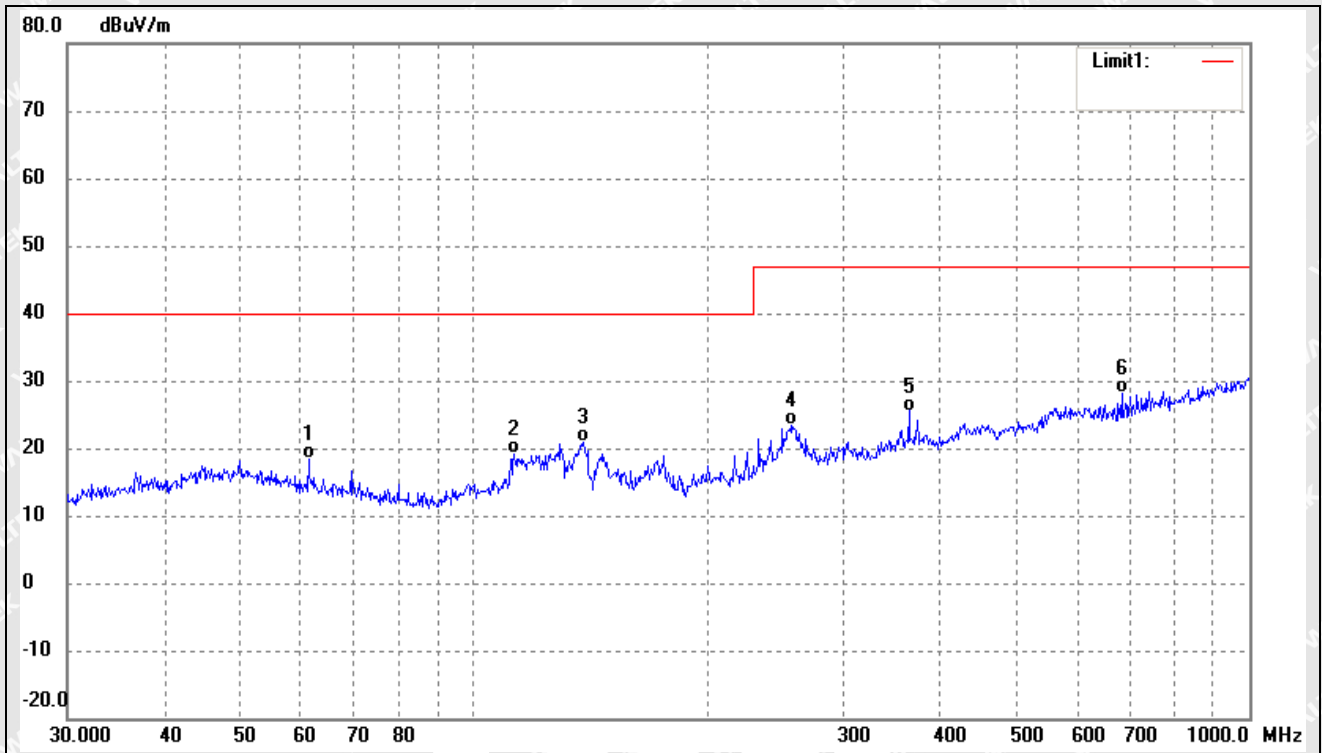

No.	Frequency (MHz)	Reading (dBuV/m)	Correct (dB/m)	Result (dBuV/m)	Limit (dBuV/m)	Margin (dB)	Degree ( )	Height (cm)	Remark
1	61.3463	30.99	-12.53	18.46	40.00	-21.54	-	-	QP
2	112.9196	31.69	-12.46	19.23	40.00	-20.77	-	-	QP
3	138.8735	35.59	-14.64	20.95	40.00	-19.05	-	-	QP
4	256.5211	32.45	-9.14	23.31	47.00	-23.69	-	-	QP
5	364.2595	31.38	-5.88	25.50	47.00	-21.50	-	-	QP
6	684.7454	30.49	-2.36	28.13	47.00	-18.87	-	-	QP



Test mode:	TM2	Polarity:	Horizontal
------------	-----	-----------	------------

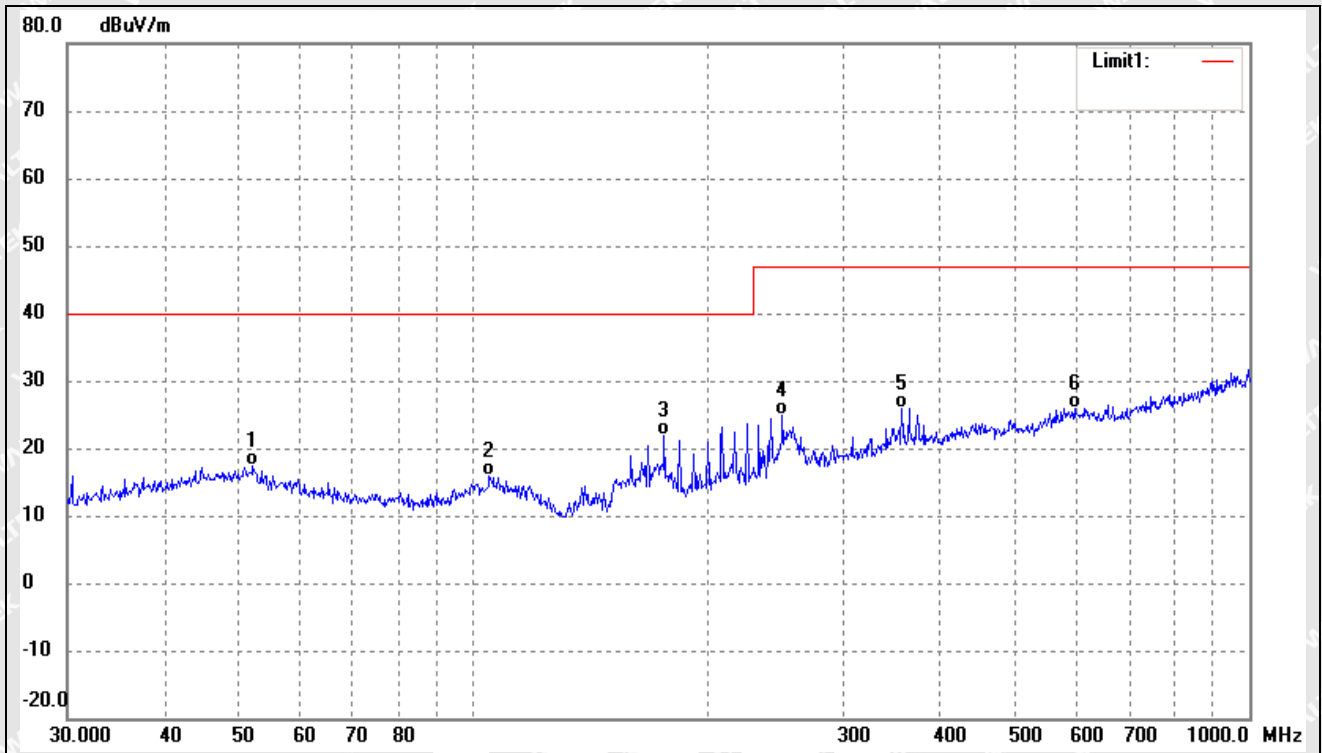

No.	Frequency (MHz)	Reading (dBuV/m)	Correct (dB/m)	Result (dBuV/m)	Limit (dBuV/m)	Margin (dB)	Degree ( )	Height (cm)	Remark
1	52.0251	27.92	-10.63	17.29	40.00	-22.71	-	-	QP
2	104.9033	28.03	-12.27	15.76	40.00	-24.24	-	-	QP
3	176.2686	35.28	-13.44	21.84	40.00	-18.16	-	-	QP
4	250.3012	34.09	-9.29	24.80	47.00	-22.20	-	-	QP
5	356.6758	31.84	-6.01	25.83	47.00	-21.17	-	-	QP
6	595.1329	28.24	-2.33	25.91	47.00	-21.09	-	-	QP



Test mode:	TM2	Polarity:	Vertical
------------	-----	-----------	----------

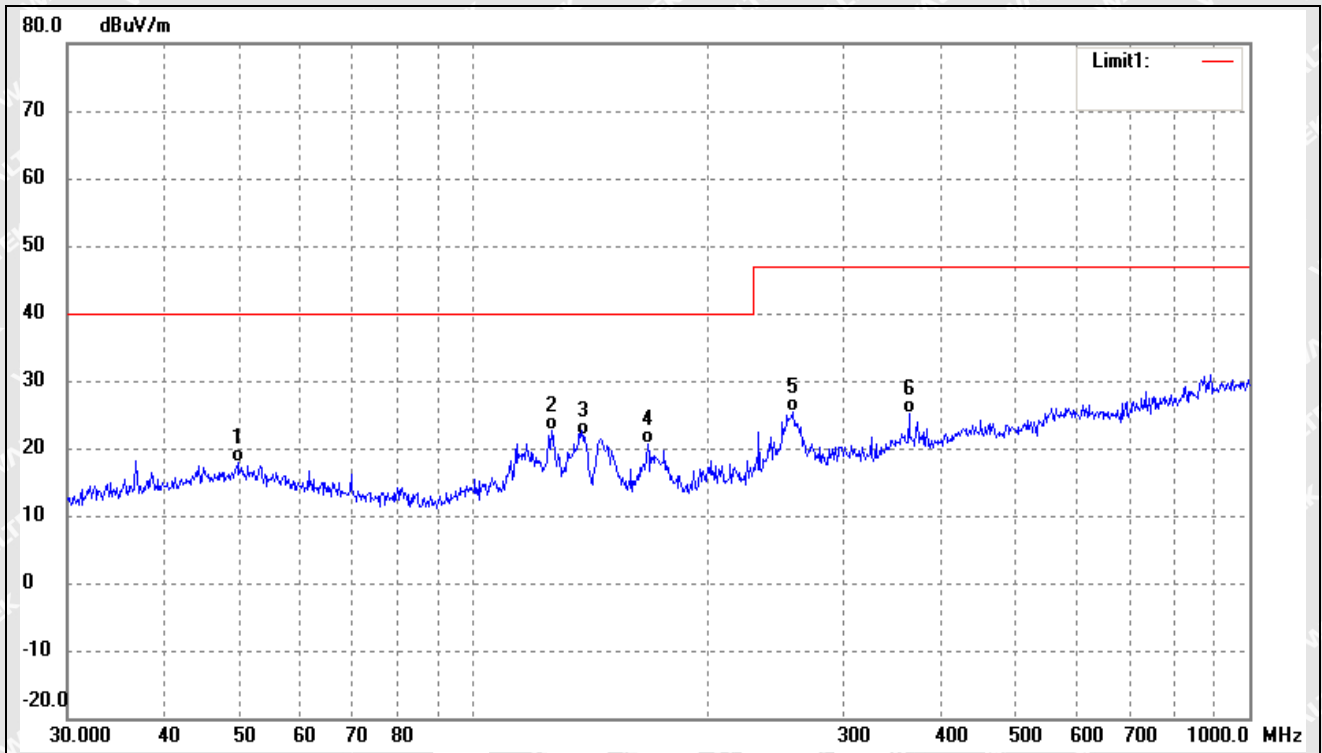

No.	Frequency (MHz)	Reading (dBuV/m)	Correct (dB/m)	Result (dBuV/m)	Limit (dBuV/m)	Margin (dB)	Degree ( )	Height (cm)	Remark
1	49.7068	28.09	-10.21	17.88	40.00	-22.12	-	-	QP
2	126.3286	37.45	-14.89	22.56	40.00	-17.44	-	-	QP
3	138.8735	36.61	-14.64	21.97	40.00	-18.03	-	-	QP
4	167.8243	34.48	-13.81	20.67	40.00	-19.33	-	-	QP
5	258.3264	34.45	-9.10	25.35	47.00	-21.65	-	-	QP
6	364.2595	31.06	-5.88	25.18	47.00	-21.82	-	-	QP



Test mode:	TM3	Polarity:	Horizontal
------------	-----	-----------	------------

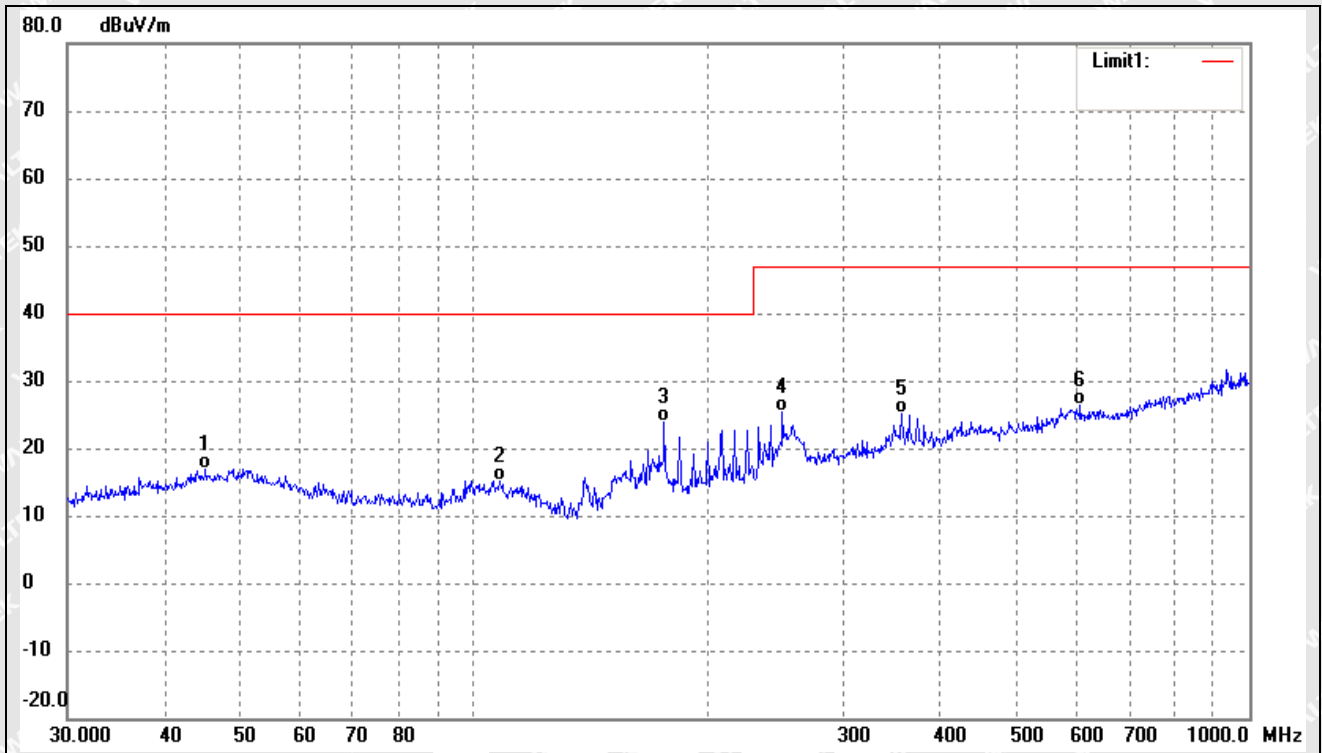

No.	Frequency (MHz)	Reading (dBuV/m)	Correct (dB/m)	Result (dBuV/m)	Limit (dBuV/m)	Margin (dB)	Degree ( )	Height (cm)	Remark
1	45.2166	27.52	-10.55	16.97	40.00	-23.03	-	-	QP
2	108.2667	27.38	-12.20	15.18	40.00	-24.82	-	-	QP
3	176.2686	37.21	-13.44	23.77	40.00	-16.23	-	-	QP
4	250.3012	34.68	-9.29	25.39	47.00	-21.61	-	-	QP
5	356.6758	31.17	-6.01	25.16	47.00	-21.84	-	-	QP
6	605.6592	28.78	-2.31	26.47	47.00	-20.53	-	-	QP



Test mode:	TM3	Polarity:	Vertical
------------	-----	-----------	----------

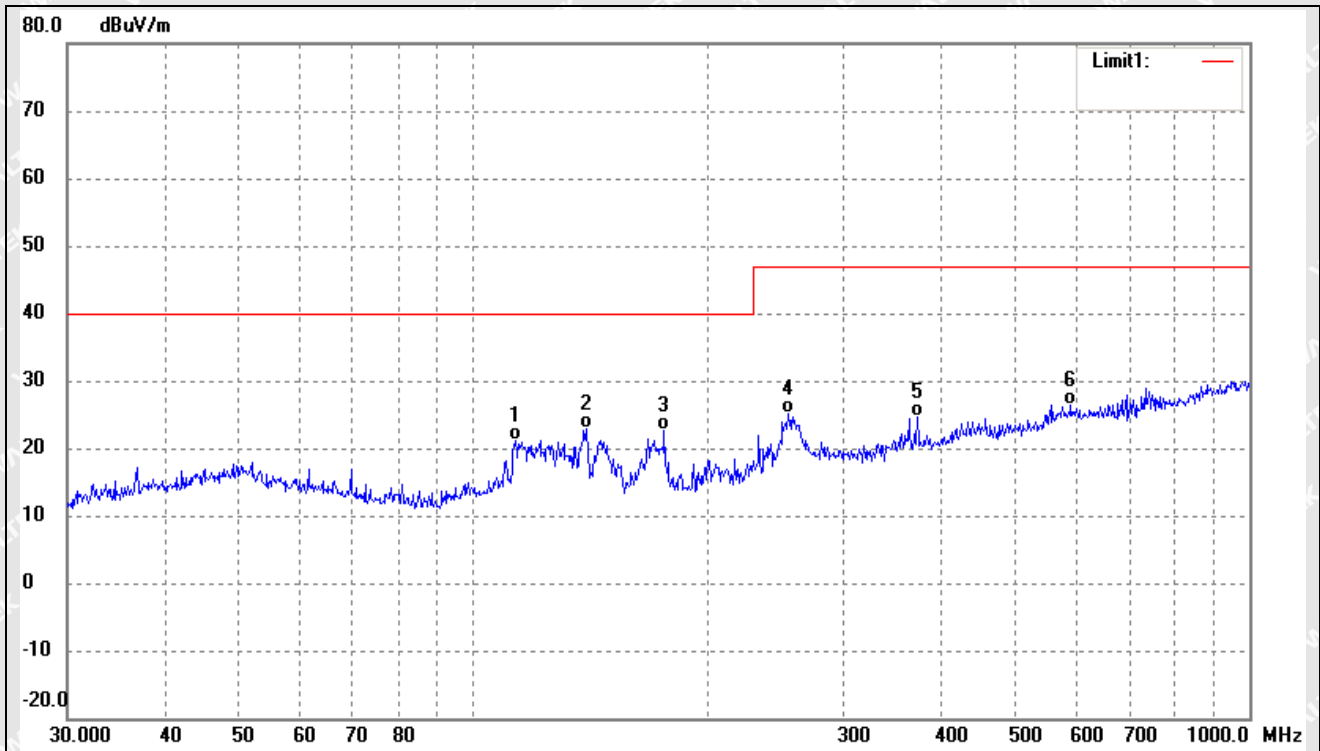

No.	Frequency (MHz)	Reading (dBuV/m)	Correct dB/m	Result (dBuV/m)	Limit (dBuV/m)	Margin (dB)	Degree ( )	Height (cm)	Remark
1	113.3163	33.61	-12.51	21.10	40.00	-18.90	-	-	QP
2	139.8508	37.48	-14.50	22.98	40.00	-17.02	-	-	QP
3	176.2686	36.03	-13.44	22.59	40.00	-17.41	-	-	QP
4	254.7284	34.27	-9.18	25.09	47.00	-21.91	-	-	QP
5	373.3112	30.37	-5.72	24.65	47.00	-22.35	-	-	QP
6	588.9051	28.82	-2.40	26.42	47.00	-20.58	-	-	QP



Test mode:	TM4	Polarity:	Horizontal
------------	-----	-----------	------------

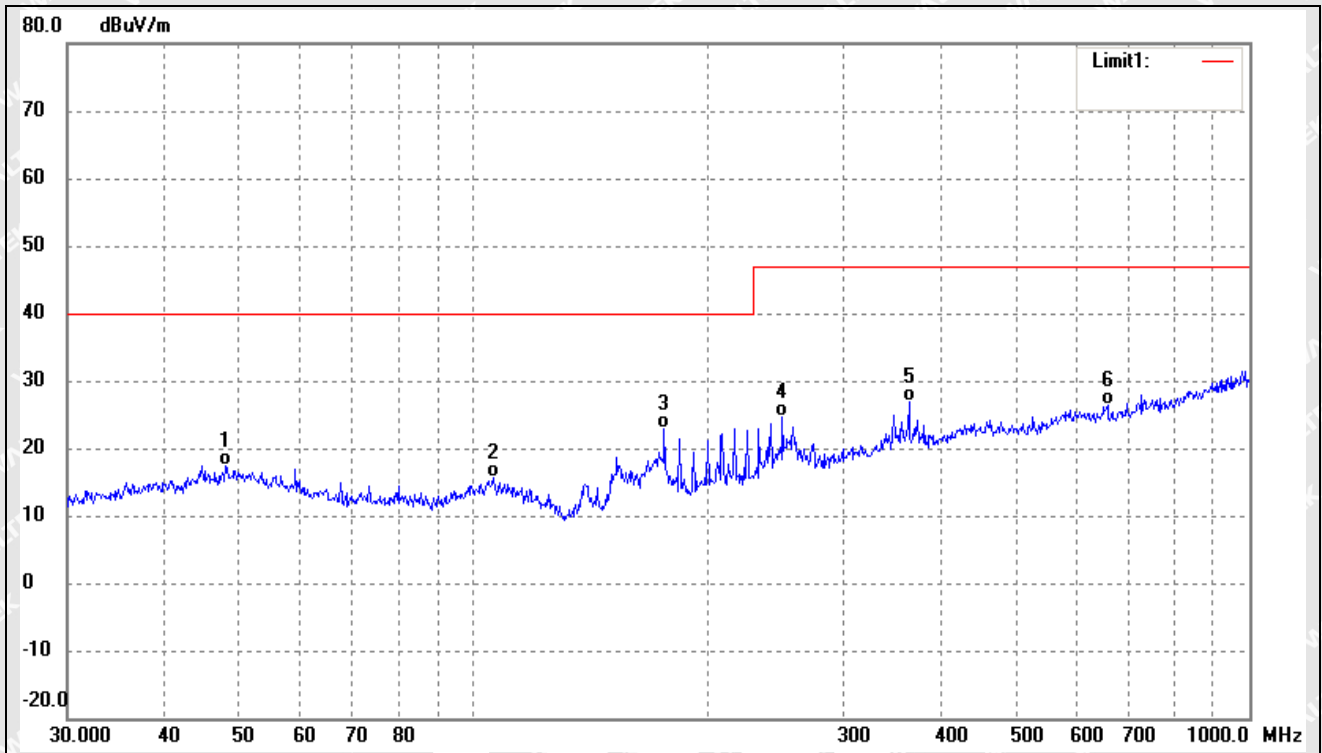

No.	Frequency (MHz)	Reading (dBuV/m)	Correct (dB/m)	Result (dBuV/m)	Limit (dBuV/m)	Margin (dB)	Degree ( )	Height (cm)	Remark
1	47.9940	27.79	-10.34	17.45	40.00	-22.55	-	-	QP
2	106.0126	27.79	-12.25	15.54	40.00	-24.46	-	-	QP
3	176.2686	36.28	-13.44	22.84	40.00	-17.16	-	-	QP
4	250.3012	33.91	-9.29	24.62	47.00	-22.38	-	-	QP
5	364.2595	32.81	-5.88	26.93	47.00	-20.07	-	-	QP
6	656.5300	28.78	-2.49	26.29	47.00	-20.71	-	-	QP



Test mode:	TM4	Polarity:	Vertical
------------	-----	-----------	----------

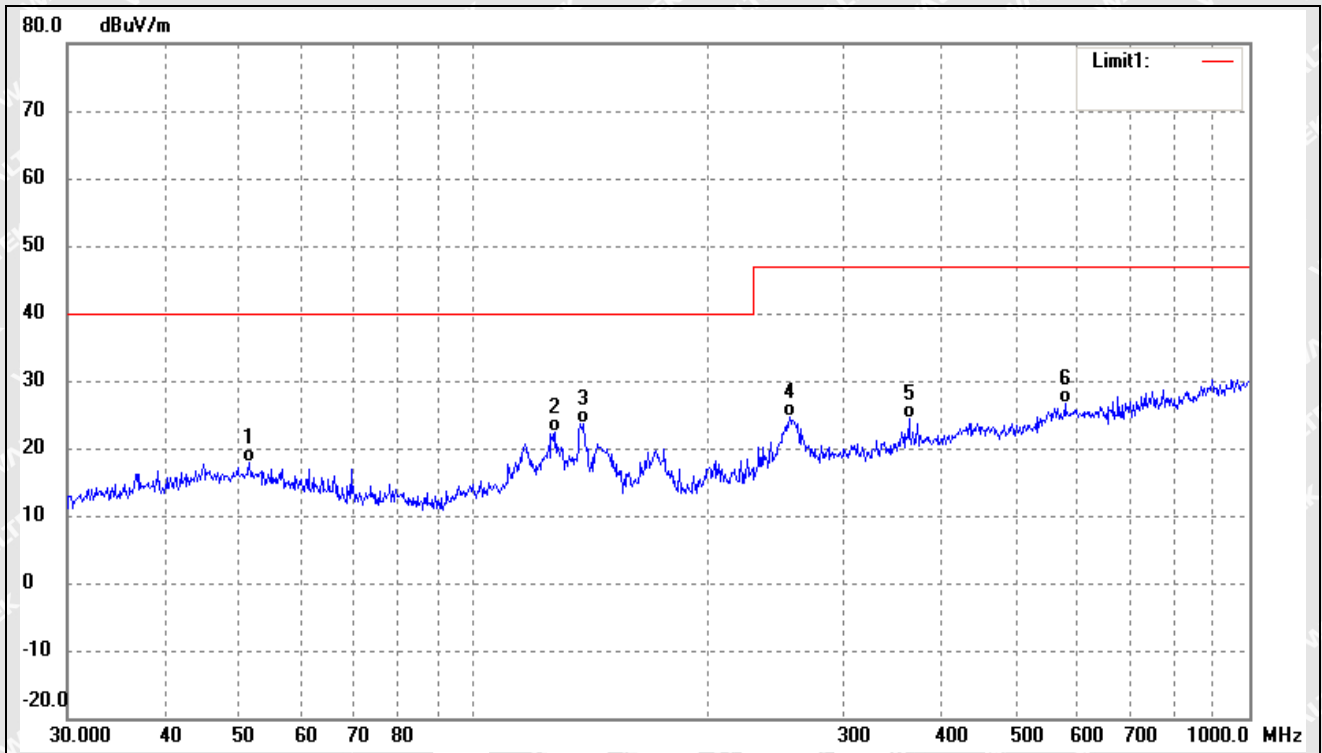

No.	Frequency (MHz)	Reading (dBuV/m)	Correct (dB/m)	Result (dBuV/m)	Limit (dBuV/m)	Margin (dB)	Degree ( )	Height (cm)	Remark
1	51.4807	28.39	-10.51	17.88	40.00	-22.12	-	-	QP
2	127.6645	37.58	-15.24	22.34	40.00	-17.66	-	-	QP
3	138.8735	38.31	-14.64	23.67	40.00	-16.33	-	-	QP
4	255.6231	33.76	-9.17	24.59	47.00	-22.41	-	-	QP
5	364.2595	30.35	-5.88	24.47	47.00	-22.53	-	-	QP
6	578.6699	29.06	-2.50	26.56	47.00	-20.44	-	-	QP





➤ Above 1GHz

Test mode:	TM1(worst case)	Polarity:	Horizontal
------------	-----------------	-----------	------------

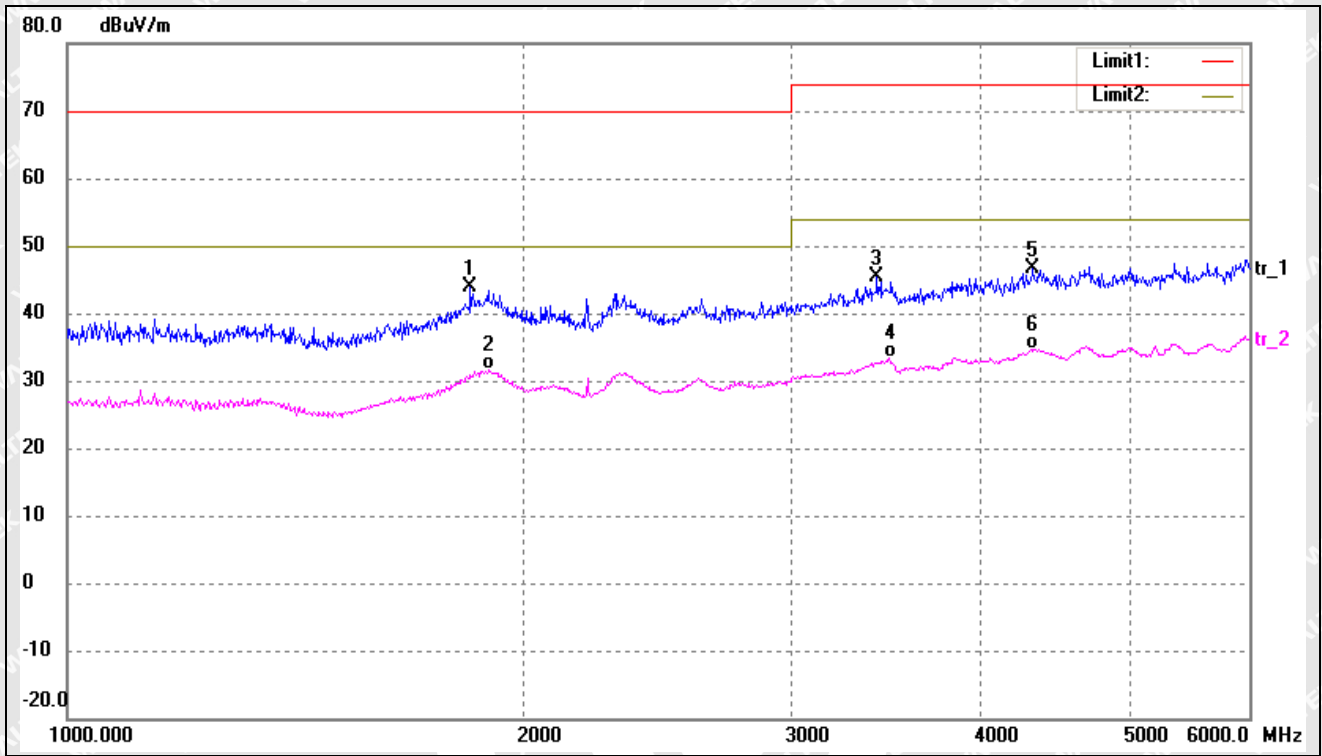

No.	Frequency (MHz)	Reading (dBuV/m)	Correct (dB/m)	Result (dBuV/m)	Limit (dBuV/m)	Margin (dB)	Degree ( )	Height (cm)	Remark
1	1842.254	52.98	-9.08	43.90	70.00	-26.10	-	-	peak
2	1895.833	40.16	-8.60	31.56	50.00	-18.44	-	-	AVG
3	3412.193	52.77	-7.45	45.32	74.00	-28.68	-	-	peak
4	3473.883	40.56	-7.28	33.28	54.00	-20.72	-	-	AVG
5	4322.645	52.15	-5.44	46.71	74.00	-27.29	-	-	peak
6	4330.397	40.10	-5.40	34.70	54.00	-19.30	-	-	AVG



Test mode:	TM1(worst case)	Polarity:	Vertical
------------	-----------------	-----------	----------

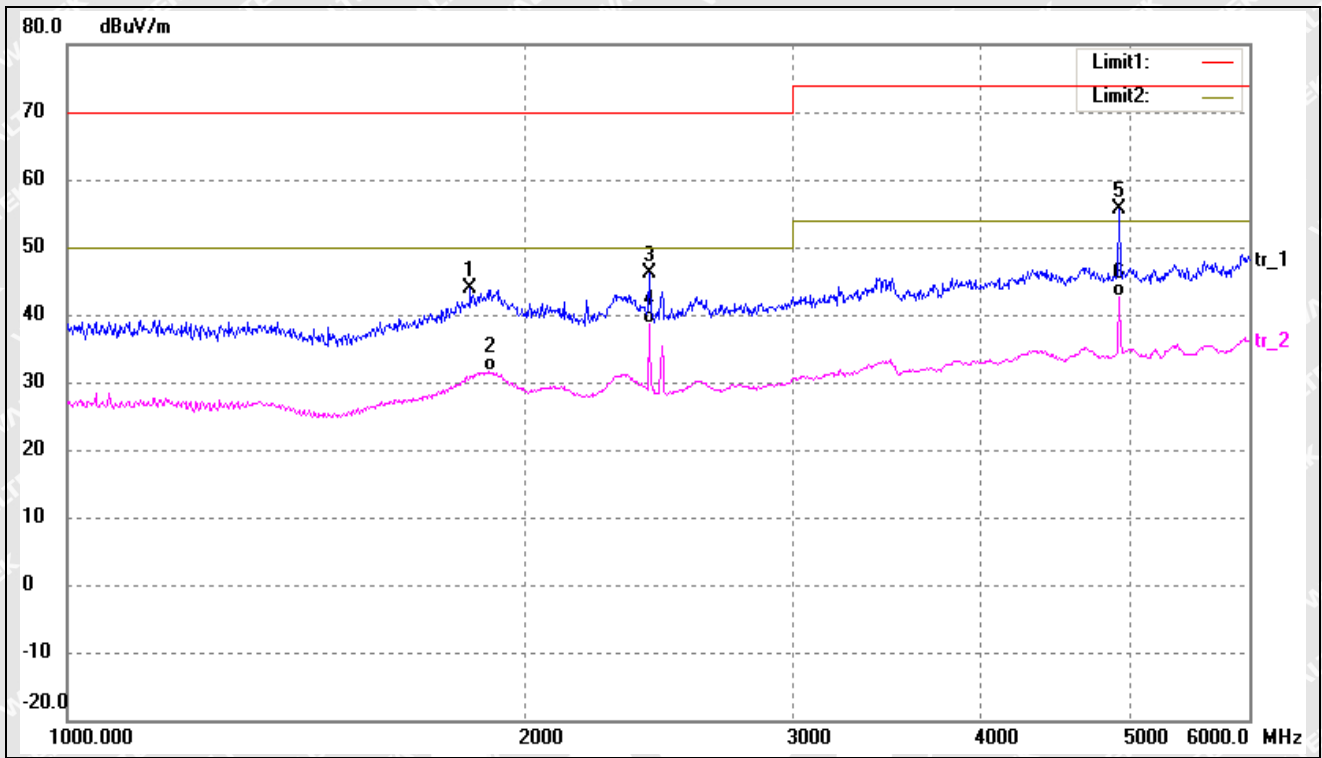

No.	Frequency (MHz)	Reading (dBuV/m)	Correct (dB/m)	Result (dBuV/m)	Limit (dBuV/m)	Margin (dB)	Degree ( )	Height (cm)	Remark
1	1842.254	52.98	-9.08	43.90	70.00	-26.10	-	-	peak
2	1895.833	40.15	-8.60	31.55	50.00	-18.45	-	-	AVG
3	2414.629	55.48	-9.45	46.03	70.00	-23.97	-	-	peak
4	2414.629	48.17	-9.45	38.72	50.00	-11.28	-	-	AVG
5	4926.683	60.17	-4.44	55.73	74.00	-18.27	-	-	peak
6	4926.683	47.14	-4.44	42.70	54.00	-11.30	-	-	AVG

Remark: '-' Means' the test Degree and Height are not recorded by the test software and only show the worst case in the test report.



## 5. Harmonic Current Emissions

---

### 5.1 Test Procedure

Test is conducting under the description of EN 61000-3-2.

### 5.2 Test Setup Block Diagram

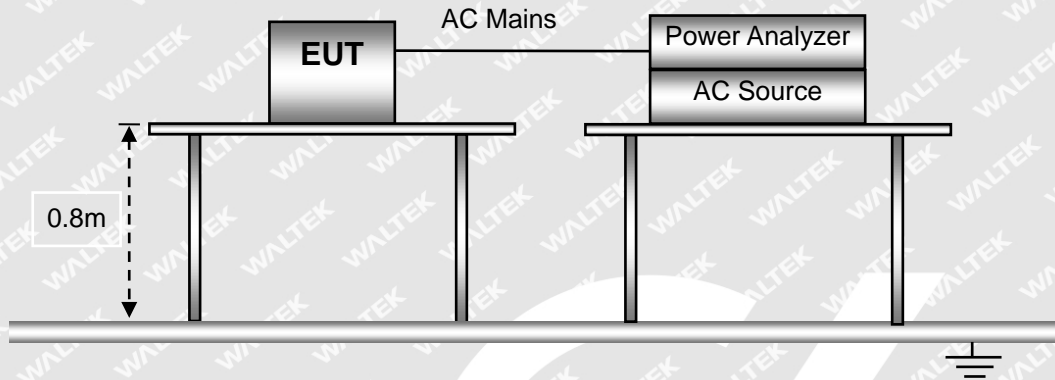

### 5.3 Test Standards

EN61000-3-2, Clause 7.1 Limits for Class A equipment.

### 5.4 Environmental Conditions

Temperature:	26 °C
Relative Humidity:	55%
ATM Pressure:	1015 mbar

### 5.5 Harmonic Current Emissions Test Data



### Harmonics – Class-A per Ed. Ed. 5.0 (2018)(Run time)

Test category: Class-A per Ed. 5.0 (2018) (European limits) Test Margin: 100

Test date: 2020-9-23

Start time: 上午 10:17:33

End time: 上午 10:20:14

Test duration (min): 2.5

Data file name: H-000566.cts\_data

Comment: Comments

Customer: Customer

Test Result: Pass

Source qualification: Normal

#### Current & voltage waveforms

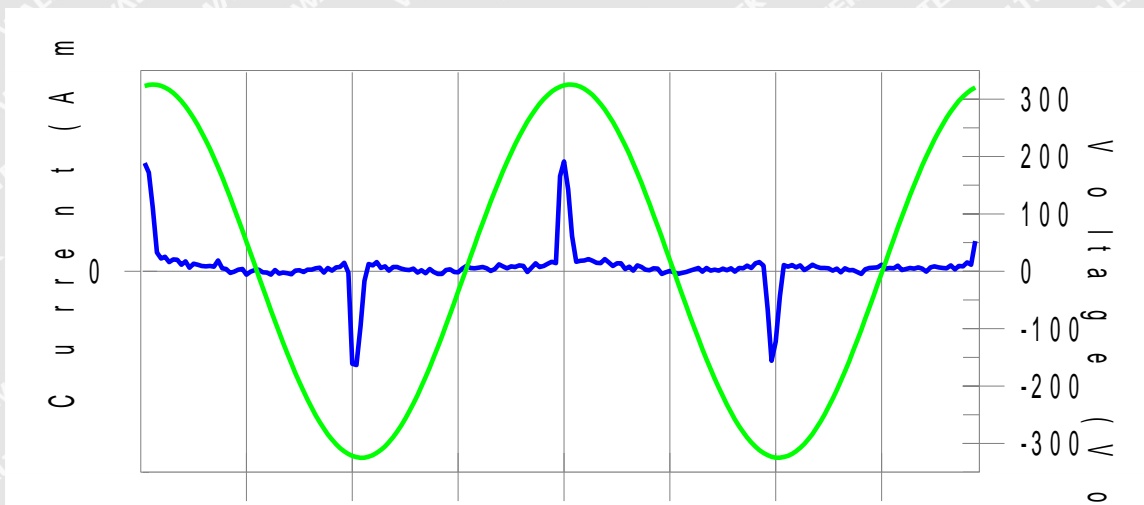

#### Harmonics and Class A limit line

#### European Limits

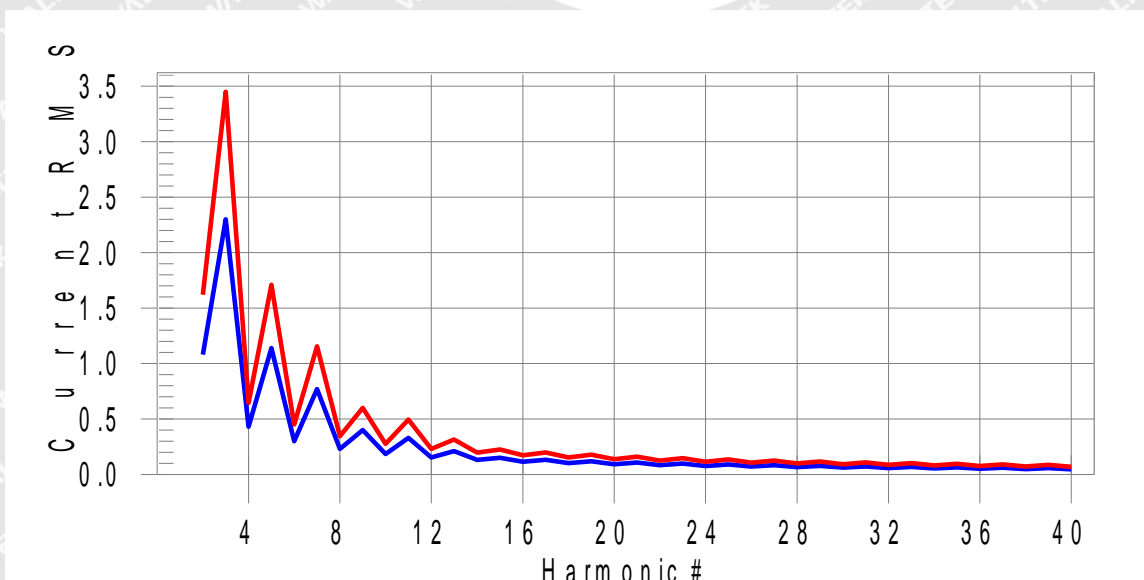

**Test result: Pass** Worst harmonics H13-1.6% of 150% limit, H13-2.4% of 100% limit



## Current Test Result Summary (Run time)

Test category: Class-A per Ed. 5.0 (2018) (European limits) Test Margin: 100

Test date: 2020-9-23 Start time: 上午 10:17:33 End time: 上午 10:20:14

Test duration (min): 2.5 Data file name: H-000566.cts\_data

Comment: Comments

Customer: Customer

Test Result: Pass

Source qualification: Normal

THC(A): 0.017

I-THD(%): 205.9

POHC(A): 0.005

POHC Limit(A): 0.251

### Highest parameter values during test:

V\_RMS (Volts): 230.08

Frequency(Hz): 50.00

I\_Peak (Amps): 0.116

I\_RMS (Amps): 0.020

I\_Fund (Amps): 0.008

Crest Factor: 5.919

Power (Watts): 1.9

Power Factor: 0.430

Harm#	Harms(avg)	100%Limit	%of Limit	Harms(max)	150%Limit	%of Limit	Status
2	0.001	1.080	N/A	0.001	1.620	N/A	Pass
3	0.006	2.300	0.3	0.007	3.450	0.2	Pass
4	0.001	0.430	N/A	0.001	0.645	N/A	Pass
5	0.006	1.140	0.6	0.006	1.710	0.4	Pass
6	0.000	0.300	N/A	0.000	0.450	N/A	Pass
7	0.006	0.770	0.8	0.006	1.155	0.5	Pass
8	0.000	0.230	N/A	0.000	0.345	N/A	Pass
9	0.006	0.400	1.4	0.006	0.600	1.0	Pass
10	0.000	0.184	N/A	0.000	0.276	N/A	Pass
11	0.005	0.330	1.6	0.005	0.495	1.1	Pass
12	0.000	0.153	N/A	0.000	0.230	N/A	Pass
13	0.005	0.210	2.4	0.005	0.315	1.6	Pass
14	0.000	0.131	N/A	0.000	0.197	N/A	Pass
15	0.005	0.150	N/A	0.005	0.225	N/A	Pass
16	0.000	0.115	N/A	0.000	0.173	N/A	Pass
17	0.004	0.132	N/A	0.004	0.198	N/A	Pass
18	0.000	0.102	N/A	0.000	0.153	N/A	Pass
19	0.004	0.118	N/A	0.004	0.178	N/A	Pass
20	0.000	0.092	N/A	0.000	0.138	N/A	Pass
21	0.003	0.107	N/A	0.003	0.161	N/A	Pass
22	0.000	0.084	N/A	0.000	0.125	N/A	Pass
23	0.003	0.098	N/A	0.003	0.147	N/A	Pass
24	0.000	0.077	N/A	0.000	0.115	N/A	Pass
25	0.002	0.090	N/A	0.002	0.135	N/A	Pass
26	0.000	0.071	N/A	0.000	0.107	N/A	Pass



27	0.002	0.083	N/A	0.002	0.125	N/A	Pass
28	0.000	0.066	N/A	0.000	0.099	N/A	Pass
29	0.001	0.078	N/A	0.001	0.116	N/A	Pass
30	0.000	0.061	N/A	0.000	0.092	N/A	Pass
31	0.001	0.073	N/A	0.001	0.109	N/A	Pass
32	0.000	0.058	N/A	0.000	0.086	N/A	Pass
33	0.001	0.068	N/A	0.001	0.102	N/A	Pass
34	0.000	0.054	N/A	0.000	0.081	N/A	Pass
35	0.001	0.064	N/A	0.001	0.096	N/A	Pass
36	0.000	0.051	N/A	0.000	0.077	N/A	Pass
37	0.001	0.061	N/A	0.001	0.091	N/A	Pass
38	0.000	0.048	N/A	0.000	0.073	N/A	Pass
39	0.001	0.058	N/A	0.001	0.087	N/A	Pass
40	0.000	0.046	N/A	0.000	0.069	N/A	Pass



# WALTEK



## Voltage Source Verification Data (Run time)

Test category: Class-A per Ed. 5.0 (2018) (European limits) Test Margin: 100

Test date: 2020-9-23 Start time: 上午 10:17:33 End time: 上午 10:20:14

Test duration (min): 2.5 Data file name: H-000566.cts\_data

Comment: Comments

Customer: Customer

Test Result: Pass

Source qualification: Normal

### Highest parameter values during test:

Voltage (Vrms):	230.08	Frequency(Hz):	50.00
I_Peak (Amps):	0.116	I_RMS (Amps):	0.020
I_Fund (Amps):	0.008	Crest Factor:	5.919
Power (Watts):	1.9	Power Factor:	0.430

Harm#	Harmonics V-rms	Limit V-rms	% of Limit	Status
2	0.063	0.460	13.77	OK
3	0.507	2.070	24.48	OK
4	0.071	0.460	15.37	OK
5	0.066	0.920	7.21	OK
6	0.038	0.460	8.23	OK
7	0.028	0.690	4.01	OK
8	0.018	0.460	3.86	OK
9	0.017	0.460	3.62	OK
10	0.012	0.460	2.67	OK
11	0.015	0.230	6.43	OK
12	0.011	0.230	4.70	OK
13	0.013	0.230	5.62	OK
14	0.004	0.230	1.81	OK
15	0.008	0.230	3.55	OK
16	0.008	0.230	3.27	OK
17	0.011	0.230	4.79	OK
18	0.011	0.230	4.88	OK
19	0.011	0.230	4.82	OK
20	0.014	0.230	6.13	OK
21	0.012	0.230	5.03	OK
22	0.004	0.230	1.70	OK
23	0.007	0.230	2.97	OK
24	0.003	0.230	1.47	OK
25	0.005	0.230		



## 6. Voltage Fluctuation and Flicker

### 6.1 Test Procedure

Test is conducting under the description of EN 61000-3-3.

### 6.2 Test Setup Block Diagram

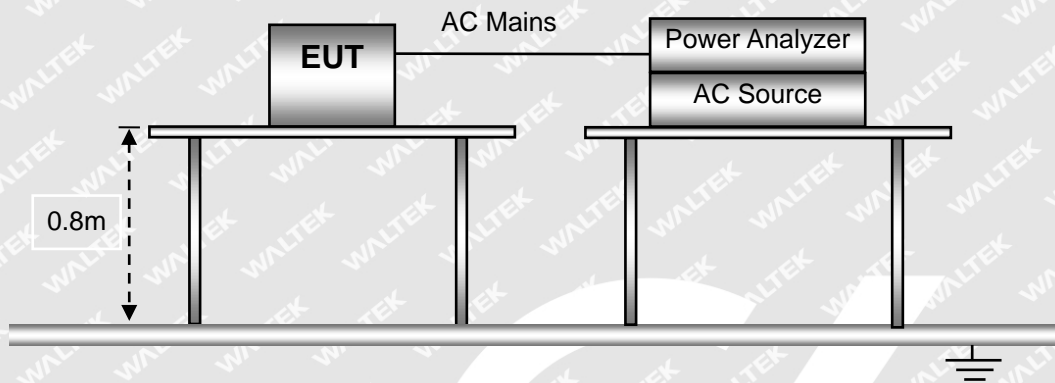

### 6.3 Test Standards

EN61000-3-3, Limit: Clause 5.

### 6.4 Environmental Conditions

Temperature:	26 °C
Relative Humidity:	55%
ATM Pressure:	1015 mbar

### 6.5 Voltage Fluctuation and Flicker Test Data





Test mode:	TM1(worst case)
------------	-----------------

**Test Result: Pass**

**Status: Test Completed**

**Pstj and limit line**

**European Limits**



**Plt and limit line**



**Parameter values recorded during the test:**

<b>Vrms at the end of test (Volt):</b>	<b>229.96</b>			
<b>T-max (mS):</b>	<b>0</b>	<b>Test limit (mS):</b>	<b>500.0</b>	<b>Pass</b>
<b>Highest dc (%):</b>	<b>0.00</b>	<b>Test limit (%):</b>	<b>3.30</b>	<b>Pass</b>
<b>Highest dmax (%):</b>	<b>0.00</b>	<b>Test limit (%):</b>	<b>4.00</b>	<b>Pass</b>
<b>Highest Pst (10 min. period):</b>	<b>0.064</b>	<b>Test limit:</b>	<b>1.000</b>	<b>Pass</b>
<b>Highest Plt (2 hr. period):</b>	<b>0.028</b>	<b>Test limit:</b>	<b>0.650</b>	<b>Pass</b>



## 7. Electrostatic Discharge (ESD)

### 7.1 Test Procedure

Test is conducting under the description of EN 61000-4-2.

### 7.2 Test Setup Block Diagram

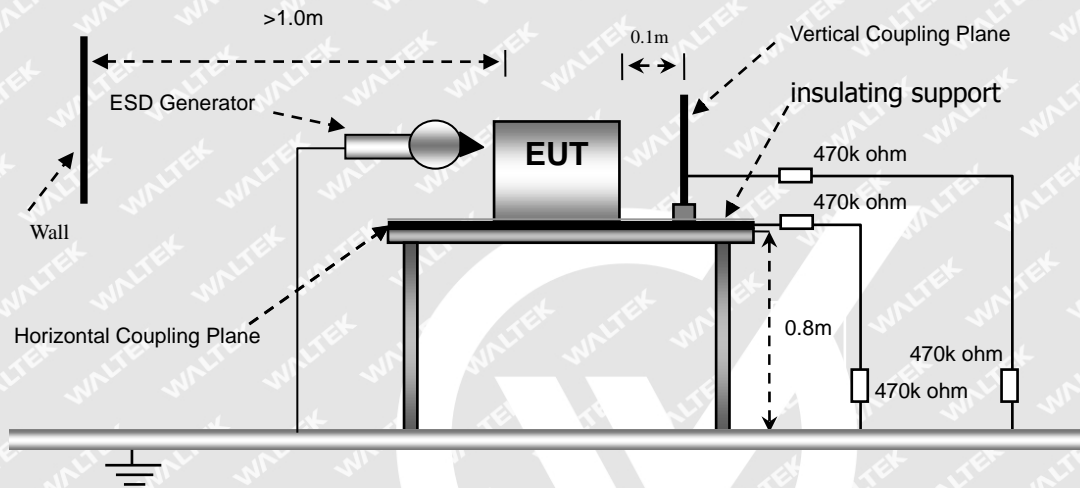

### 7.3 Test Performance

Performance Criterion:	Mode	Verdict
		TM1-TM7

Note: TM5-TM7 for TT,TR

### 7.4 Environmental Conditions

Temperature:	26 °C
Relative Humidity:	55%
ATM Pressure:	1011 mbar

### 7.5 Electrostatic Discharge Immunity Test Data



Test mode	TM5-TM7							
EN 61000-4-2	Test Levels (kV)							
Test Points	-2	+2	-4	+4	-6	+6	-8	+8
<b>Air Discharge</b>								
<b>Indicator Light</b>	A	A	A	A	A	A	A	A
<b>Shell Gap</b>	A	A	A	A	A	A	A	A
<b>Button</b>	A	A	A	A	A	A	A	A
<b>Port</b>	A	A	A	A	A	A	A	A
<b>Direct Contact Discharge</b>								
<b>Port</b>	A	A	A	A	/	/	/	/
<b>Indirect Contact Discharge</b>								
<b>HCP (6 Sides)</b>	A	A	A	A	/	/	/	/
<b>VCP (4 Sides)</b>	A	A	A	A	/	/	/	/

Test Result: Pass





## 8. Radio Frequency Electromagnetic Field (R/S)

### 8.1 Test Procedure

Test is conducting under the description of EN 61000-4-3.

### 8.2 Test Setup Block Diagram

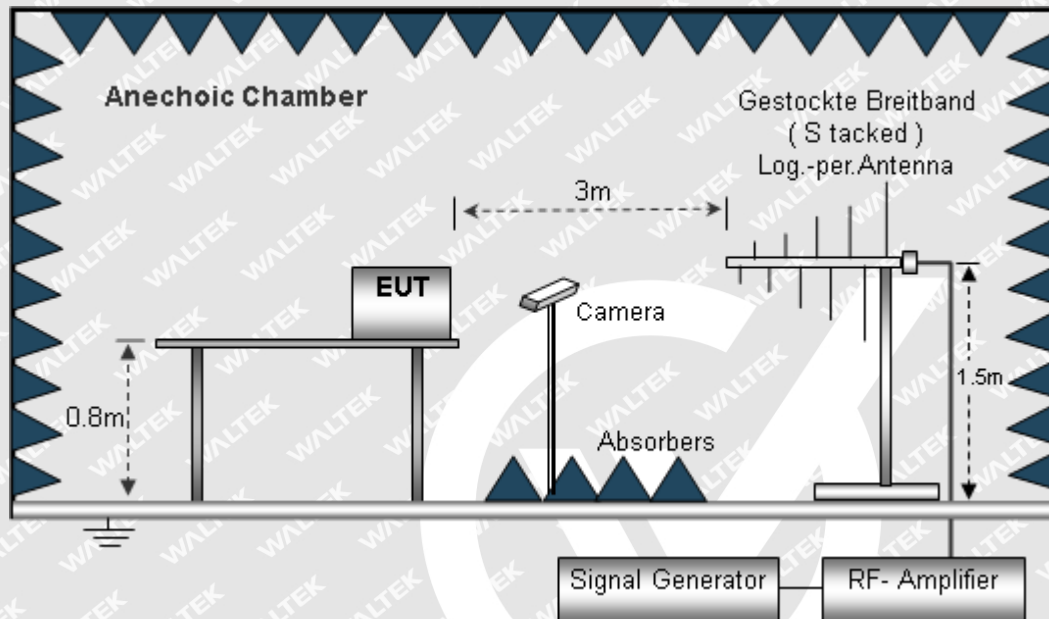

### 8.3 Test Performance

Performance Criterion:	Mode	Verdict
	TM1-TM7	A

Note: TM5-TM7 for CT,CR

### 8.4 Environmental Conditions

Temperature:	25 °C
Relative Humidity:	52%
ATM Pressure:	1010 mbar

### 8.5 Continuous Radiated Disturbances Test Data

Frequency step: 1% of fundamental

Dwell time: 1 second

Modulation: AM by 1kHz sine wave with 80% modulation depth



Test mode		TM1-TM7							
Frequency Range(MHz)	Field (V/m)	Front		Rear		Left Side		Right Side	
		VERT	HORI	VERT	HORI	VERT	HORI	VERT	HORI
80-1000	3	A	A	A	A	A	A	A	A
1000-3000	3	A	A	A	A	A	A	A	A
3000-6000	3	A	A	A	A	A	A	A	A

Test Result: Pass



# WALTEK



## 9. Fast Transients, Common Mode (EFT)

### 9.1 Test Procedure

Test is conducting under the description of EN 61000-4-4.

### 9.2 Test Setup Block Diagram

For AC Mains or DC Ports:

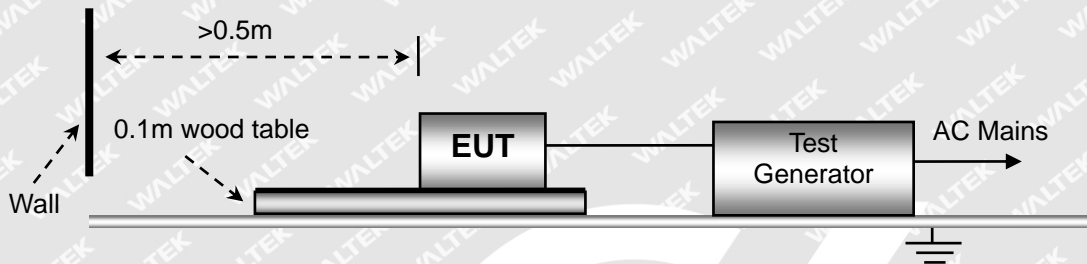

For Signal or Telecommunication Ports:

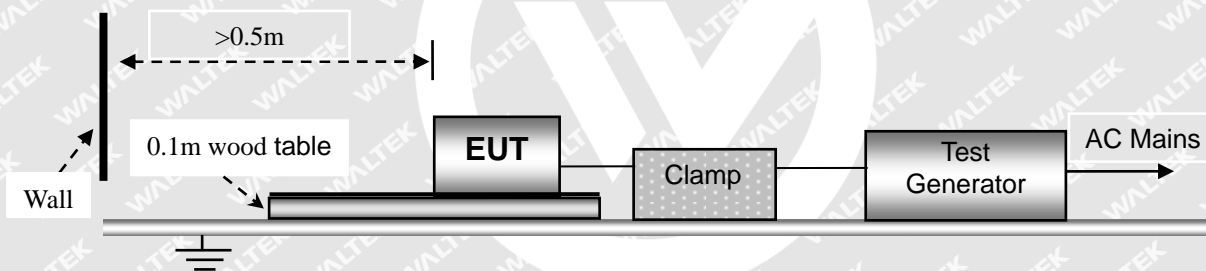

### 9.3 Test Performance

Performance Criterion:	Mode	Verdict
	TM1-TM7	B
Note: TM5-TM7 for TT,TR		

### 9.4 Environmental Conditions

Temperature:	22 °C
Relative Humidity:	53%
ATM Pressure:	1011 mbar

### 9.5 Electrical Fast Transients Test Data



Test Mode		TM1-TM7							
EN 61000-4-4 Test Line		Test Levels (kV)							
		+0.5	-0.5	+1.0	-1.0	+2.0	-2.0	+4.0	-4.0
AC Main Power port	L	A	A	A	A	/	/	/	/
	N	A	A	A	A	/	/	/	/
	PE	/	/	/	/	/	/	/	/
	L-N	A	A	A	A	/	/	/	/
	L-PE	/	/	/	/	/	/	/	/
	N-PE	/	/	/	/	/	/	/	/
	L-N-PE	/	/	/	/	/	/	/	/
Signal ports	RJ45	A	A	/	/	/	/	/	/

Test Result: Pass



# WALTEK



## 10. Surges

### 10.1 Test Procedure

Test is conducting under the description of EN 61000-4-5.

### 10.2 Test Setup Block Diagram

For AC Mains or DC Ports:

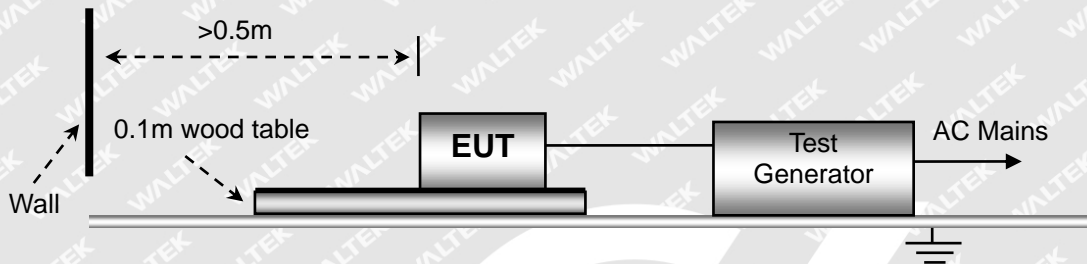

For Signal or Telecommunication Ports:

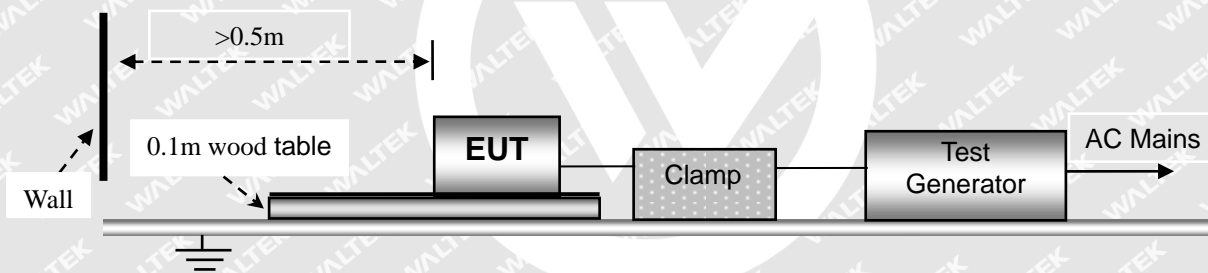

### 10.3 Test Performance

Performance Criterion:	Mode	Verdict
	TM1-TM7	B
Note: TM5-TM7 for TT,TR		

### 10.4 Environmental Conditions

Temperature:	25 °C
Relative Humidity:	53%
ATM Pressure:	1011 mbar

### 10.5 Surge Test Data





Test Mode	TM1-TM7			
Voltage	Poll	Path	Pass	Fail
0.5kV	±	L-N	A	/
1kV	±	L-N	A	/
2kV	±	L-N, L-PE, N-PE	/	/
4kV	±	L-N, L-PE, N-PE	/	/

Test Mode	RJ45			
Voltage	Poll	Path	Pass	Fail
0.5kV	±	RJ45	A	/
1kV	±	RJ45	A	/

Test Result: Pass





## 11. Radio Frequency, Common Mode (C/S)

### 11.1 Test Procedure

Test is conducting under the description of EN 61000-4-6.

### 11.2 Test Setup Block Diagram

For AC Mains or DC Input:

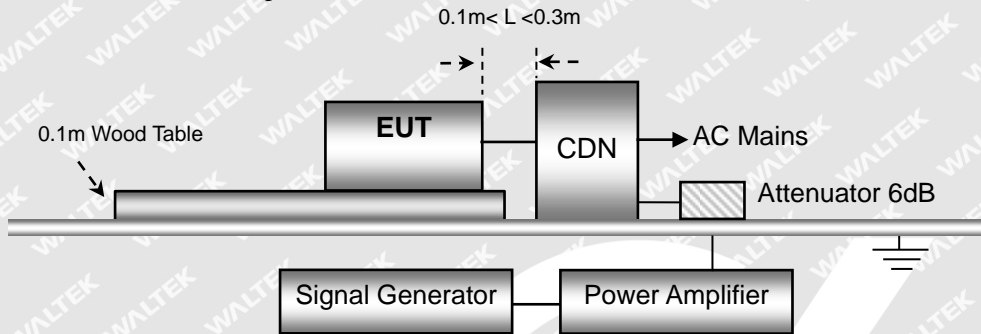

For Signal or Telecommunication Ports:

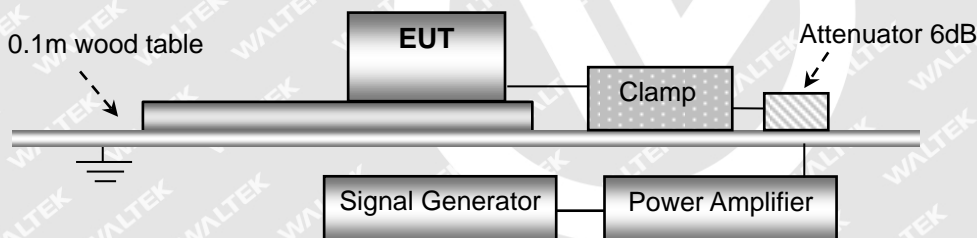

### 11.3 Test Performance

Performance Criterion:	Mode	Verdict
	TM1-TM7	A

Note: TM5-TM7 for CT,CR

### 11.4 Environmental Conditions

Temperature:	25 °C
Relative Humidity:	53%
ATM Pressure:	1011 mbar

### 11.5 Continuous Conducted Disturbances Test Data

Sweep frequency range: 150kHz~80MHz

Frequency step: 1% of fundamental

Dwell time: 1 second



Test Mode		TM1-TM7		
Level	Voltage (V) (rms, unmodulated)	Modulation:	Pass	Fail
1	1	AM 80%, 1kHz sinewave	/	/
2	3	AM 80%, 1kHz sinewave	A	/
3	10	AM 80%, 1kHz sinewave	/	/
X	Special	/	/	/

Test Mode		RJ45		
Level	Voltage (V) (rms, unmodulated)	Modulation:	Pass	Fail
1	1	AM 80%, 1kHz sinewave	/	/
2	3	AM 80%, 1kHz sinewave	A	/
3	10	AM 80%, 1kHz sinewave	/	/
X	Special	/	/	/

Test Result: Pass



# WALTEK



## 12. Voltage Dips and Interruptions

### 12.1 Test Procedure

Test is conducting under the description of EN 61000-4-11.

### 12.2 Test Setup Block Diagram

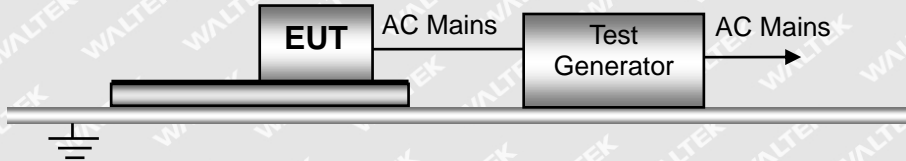

### 12.3 Test Performance

Performance Criterion:	Mode	Verdict
	TM1-TM7	B for voltage dip/ C for voltage interruption
Note: TM5-TM7 for TT,TR		

### 12.4 Environmental Conditions

Temperature:	25 °C
Relative Humidity:	50%
ATM Pressure:	1011 mbar

### 12.5 Voltage Dips And Interruptions Test Data

U: Voltage dips in %  $U_T$  ( $U_T$  is rated voltage for the EUT)

T: Test duration

Level	U	T	Phase Angle	N	Pass	Fail
1	100%	10ms	0/90/180/270	3	A	/
2	100%	20ms	0/90/180/270	3	B	/
3	30%	500ms	0/90/180/270	3	B	/
4	100%	5000ms	0/90/180/270	3	B	/

Test Result: Pass



## EXHIBIT 1 - EUT PHOTOGRAPHS

---

Please refer to “ANNEX”.



# WALTEK



## EXHIBIT 2 - TEST SETUP PHOTOGRAPHS

**Conducted Emission  
Test Setup**



**Conducted Emission  
Test Setup(RJ45 Port)**





**Radiation Emission Test  
View(30MHz to 1GHz)**

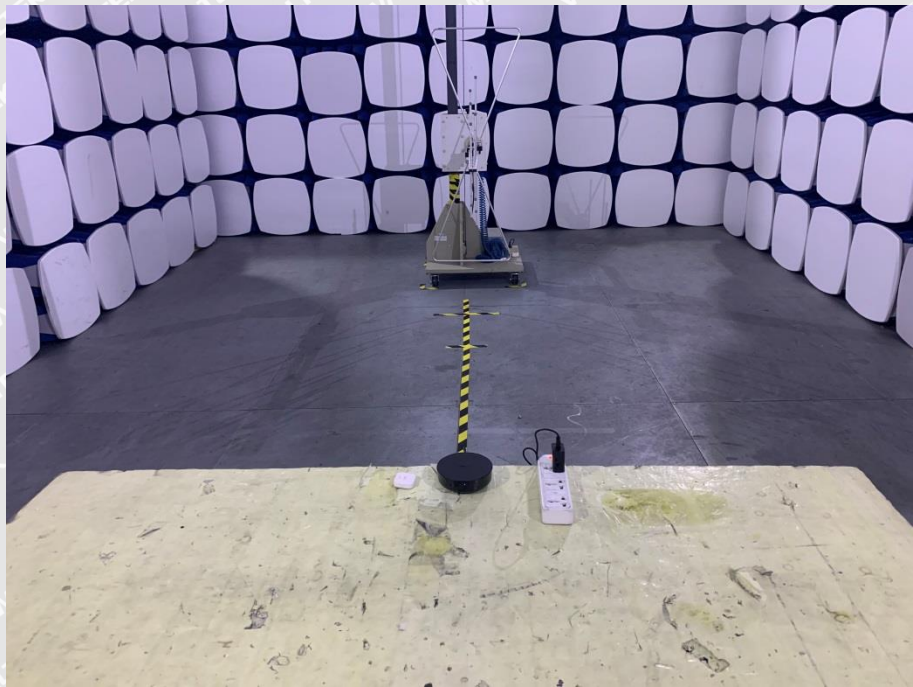

**Radiation Emission Test  
Setup ((Above 1GHz)**

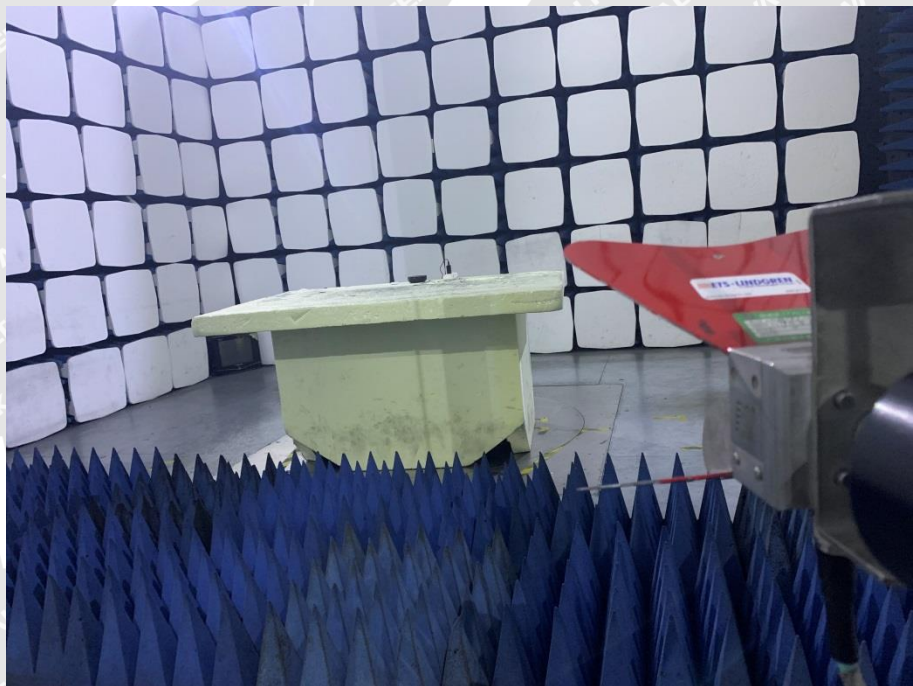



**Harmonic/Flicker Test  
View**



**EN 61000-4-2 Test View**







**EN 61000-4-3 Test View**

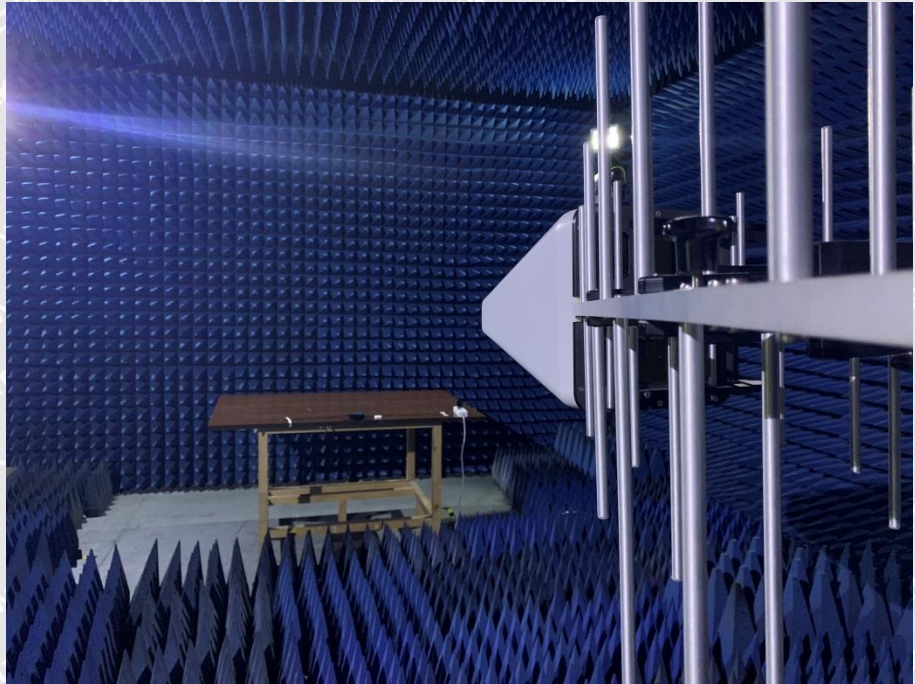

**EN 61000-4-4/5/11 Test View**





**EN 61000-4-4/5/11 Test  
View(RJ45 Port)**



**EN 61000-4-6 Test View**





**EN 61000-4-6 Test View  
(RJ45 Port)**

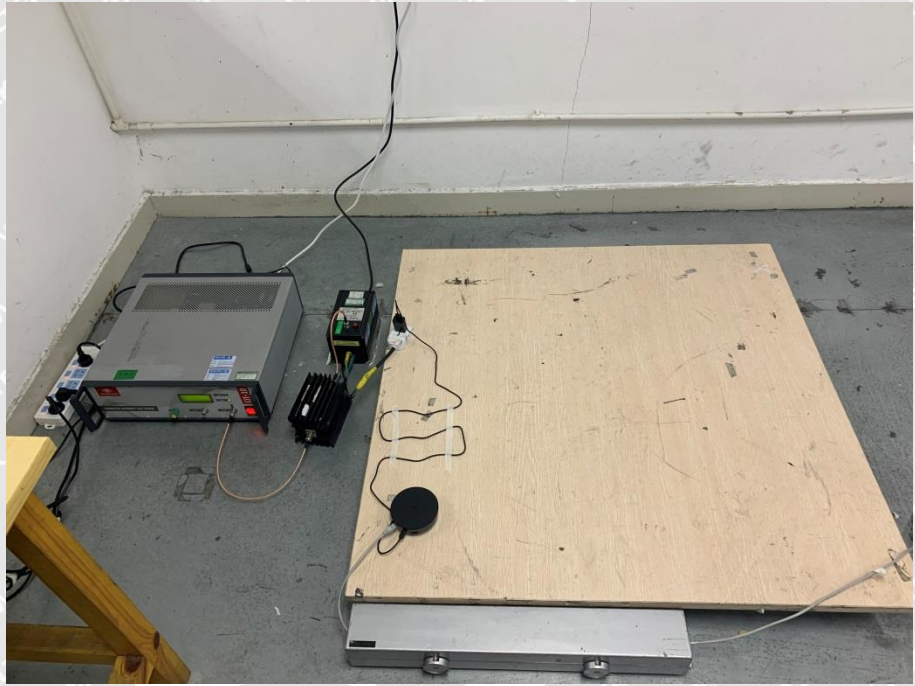

**\*\*\*\*\* END OF REPORT \*\*\*\*\***

**WALTEK**