



RADIO TEST REPORT

ETSI EN 300 328 V2.2.2 (2019-07)

Product : Wireless Earphone

Trade Mark : Blackview

Model Name : AirBuds 10

Family Model : N/A

Report No. : STR230130001002E

Prepared for

DOKE COMMUNICATION (HK) LIMITED

RM 1902 EASEY COMM BLDG 253-261 HENNESSY ROAD WANCHAI HK CHINA

Prepared by

Shenzhen NTEK Testing Technology Co., Ltd.

1/F, Building E, Fenda Science Park, Sanwei Community, Xixiang Street
Bao'an District, Shenzhen 518126 P.R. China

Tel. 400-800-6106, 0755-2320 0050, 0755-2320 0090

Website: <http://www.ntek.org.cn>

Table of Contents

Page

1 . GENERAL INFORMATION	7
1.1 GENERAL DESCRIPTION OF EUT	7
1.2 INFORMATION ABOUT THE EUT	8
1.3 TEST CONDITIONS	13
1.4 TEST CONFIGURATION OF EUT	13
1.5 DESCRIPTION OF TEST CONDITIONS	14
1.6 DESCRIPTION OF SUPPORT UNITS	15
1.7 EQUIPMENTS LIST FOR ALL TEST ITEMS	16
2 . SUMMARY OF TEST RESULTS	17
2.1 TEST FACILITY	18
3 . RF OUTPUT POWER	19
3.1 LIMITS OF RF OUTPUT POWER	19
3.2 TEST PROCEDURE	19
3.3 DEVIATION FROM TEST STANDARD	19
3.4 TEST SETUP	19
3.5 TEST RESULTS	20
4 . ACCUMULATED TRANSMIT TIME, FREQUENCY OCCUPATION AND HOPPING SEQUENCE	21
4.1 LIMITS OF ACCUMULATED TRANSMIT TIME, FREQUENCY OCCUPATION AND HOPPING SEQUENCE	21
4.2 TEST PROCEDURE	21
4.3 DEVIATION FROM TEST STANDARD	21
4.4 TEST SETUP	22
4.5 TEST RESULTS	22
5 . OCCUPIED CHANNEL BANDWIDTH	23
5.1 LIMITS OF OCCUPIED CHANNEL BANDWIDTH	23
5.2 TEST PROCEDURE	23
5.3 DEVIATION FROM TEST STANDARD	24
5.4 TEST SETUP	24
5.5 TEST RESULTS	24
6 . TRANSMITTER UNWANTED EMISSIONS IN THE OUT-OF-BAND DOMAIN	25
6.1 LIMITS OF TRANSMITTER UNWANTED EMISSIONS IN THE OUT-OF-BAND DOMAIN	25

Table of Contents

Page

6.2 TEST PROCEDURE	25
6.3 DEVIATION FROM TEST STANDARD	26
6.4 TEST SETUP	26
6.5 TEST RESULTS	26
7 . HOPPING FREQUENCY SEPARATION	27
7.1 LIMITS OF HOPPING FREQUENCY SEPARATION	27
7.2 TEST PROCEDURE	27
7.3 DEVIATION FROM TEST STANDARD	27
7.4 TEST SETUP	28
7.5 TEST RESULTS	28
8 . TRANSMITTER UNWANTED EMISSIONS IN THE SPURIOUS DOMAIN	29
8.1 LIMITS OF TRANSMITTER TRANSMITTER UNWANTED EMISSIONS IN THE SPURIOUS DOMAIN	29
8.2 TEST PROCEDURE	29
8.3 DEVIATION FROM TEST STANDARD	29
8.4 TEST SETUP	30
8.5 TEST RESULTS (Radiated measurement)	31
8.6 TEST RESULTS (Conducted measurement)	33
9 . RECEIVER SPURIOUS EMISSIONS	34
9.1 LIMITS OF RECEIVER SPURIOUS RADIATION	34
9.2 TEST PROCEDURE	34
9.3 DEVIATION FROM TEST STANDARD	34
9.4 TEST SETUP	35
9.5 TEST RESULTS (Radiated measurement)	36
9.6 TEST RESULTS (Conducted measurement)	37
10. RECEIVER BLOCKING	38
10.1 PERFORMANCE CRITERIA	38
10.2 LIMITS OF RECEIVER BLOCKING	38
10.3 TEST PROCEDURE	39
10.4 DEVIATION FROM TEST STANDARD	40
10.5 TEST SETUP	40
10.6 TEST RESULTS	41
11. TEST RESULTS	45
Left	45
11.1 Accumulated Transmit Time	45

Table of Contents	Page
11.2 Frequency Occupation	52
11.3 Dwell Time One Burst	59
11.4 RF Output Power	66
11.5 Hopping Frequency Separation	68
11.6 Occupied Channel Bandwidth	72
11.7 Transmitter unwanted emissions in the out-of-band domain	75
11.8 Transmitter unwanted emissions in the spurious domain	78
11.9 Receiver spurious emissions	82
11.10 Hopping Sequence	86
Right	87
11.1 Accumulated Transmit Time	87
11.2 Frequency Occupation	94
11.3 Dwell Time One Burst	101
11.4 RF Output Power	108
11.5 Hopping Frequency Separation	110
11.6 Occupied Channel Bandwidth	114
11.7 Transmitter unwanted emissions in the out-of-band domain	117
11.8 Transmitter unwanted emissions in the spurious domain	120
11.9 Receiver spurious emissions	125
11.10 Hopping Sequence	129
12. EUT TEST PHOTO	130
SPURIOUS EMISSIONS MEASUREMENT PHOTOS	130

Revision History

Report No.	Version	Description	Issued Date
STR230130001002E	Rev.01	Initial issue of report	Feb 28, 2023

1. GENERAL INFORMATION

1.1 GENERAL DESCRIPTION OF EUT

Equipment	Wireless Earphone	
Trade Mark	Blackview	
Model Name.	AirBuds 10	
Family Model	N/A	
Model Difference	N/A	
Product Description	The EUT is Wireless Earphone	
	Operation Frequency:	2402~2480 MHz
	Modulatin Type:	GFSK,π/4-DQPSK
	Modulation Technology:	FHSS
	Adaptive/non-adaptive	Adaptive equipment
	Receiver categories	Left:2,Right:3
	Number Of Channel	79CH
	Antenna Designation:	Chip antenna
	Antenna Gain(Peak)	1.75 dBi
	Based on the application, features, or specification exhibited in User's Manual, the EUT is considered as an ITE/Computing Device. More details of EUT technical specification, please refer to the User's Manual.	
Channel List	Refer to below Table	
Adapter	N/A	
Battery	Earphone: DC 3.7V, 50mAh Charging case: DC 3.7V, 550mAh	
Rating	Earphone: DC 3.7V from Battery or DC 5V from Charging case Charging case: DC 3.7V from Battery or DC 5V from type-C port.	
I/O Ports	Refer to users manual	
Hardware Version	V4	
Software Version	V7	

Note:

1. For a more detailed features description, please refer to the manufacturer's specifications or the User's Manual.

2. 79 channels are provided to (GFSK, $\pi/4$ -DQPSK)

Channel	Frequency (MHz)
00	2402
01	2403
.....
.....
.....	...
.....
77	2479
78	2480

1.2 INFORMATION ABOUT THE EUT

a) The type of modulation used by the equipment:

- FHSS
- other forms of modulation

b) In case of FHSS modulation:

- In case of non-Adaptive Frequency Hopping equipment:
The number of Hopping Frequencies:
- In case of Adaptive Frequency Hopping Equipment:
The maximum number of Hopping Frequencies: 79
The minimum number of Hopping Frequencies: 79
- The (average) Dwell Time: 314.683ms (Left), 328.89(Right) Maximum

c) Adaptive / non-adaptive equipment:

- non-adaptive Equipment
- adaptive Equipment without the possibility to switch to a non-adaptive mode
- adaptive Equipment which can also operate in a non-adaptive mode

d) In case of adaptive equipment:

The maximum Channel Occupancy Time implemented by the equipment:/..... ms

- The equipment has implemented an LBT based DAA mechanism
 - In case of equipment using modulation different from FHSS:
 - The equipment is Frame Based equipment
 - The equipment is Load Based equipment
 - The equipment can switch dynamically between Frame Based and Load Based equipment

The CCA time implemented by the equipment:/.. μ s

- The equipment has implemented a non-LBT based DAA mechanism
- The equipment can operate in more than one adaptive mode

e) In case of non-adaptive Equipment:

The maximum RF Output Power (e.i.r.p.):

The maximum (corresponding) Duty Cycle:

Equipment with dynamic behaviour, that behaviour is described here. (e.g. the different combinations of duty cycle and corresponding power levels to be declared):

f) The worst case operational mode for each of the following tests:

- RF Output Power
Left: GFSK, Right: GFSK
- Power Spectral Density
N/A
- Duty cycle, Tx-Sequence, Tx-gap
N/A
- Accumulated Transmit time, Frequency Occupation & Hopping Sequence (only for FHSS equipment)
Left: GFSK, Right: $\pi/4$ -DQPSK
- Hopping Frequency Separation (only for FHSS equipment)
Left: GFSK, Right: GFSK
- Medium Utilization
N/A
- Adaptivity
N/A
- Receiver Blocking
Left: GFSK, Right: $\pi/4$ -DQPSK
- Nominal Channel Bandwidth
Left: $\pi/4$ -DQPSK, Right: $\pi/4$ -DQPSK
- Transmitter unwanted emissions in the OOB domain
Left: GFSK, Right: $\pi/4$ -DQPSK
- Transmitter unwanted emissions in the spurious domain
Left: GFSK, Right: GFSK
- Receiver spurious emissions
Left: $\pi/4$ -DQPSK, Right: GFSK

g) The different transmit operating modes (tick all that apply):

- Operating mode 1: Single Antenna Equipment
- Equipment with only one antenna
- Equipment with two diversity antennas but only one antenna active at any moment in time
- Smart Antenna Systems with two or more antennas, but operating in a (legacy) mode where only one antenna is used (e.g. IEEE 802.11™ [i.3] legacy mode in smart antenna systems)
- Operating mode 2: Smart Antenna Systems - Multiple Antennas without beam forming
- Single spatial stream / Standard throughput / (e.g. IEEE 802.11™ [i.3] legacy mode)
- High Throughput (> 1 spatial stream) using Nominal Channel Bandwidth 1
- High Throughput (> 1 spatial stream) using Nominal Channel Bandwidth 2

NOTE 1: Add more lines if more channel bandwidths are supported.

- Operating mode 3: Smart Antenna Systems - Multiple Antennas with beam forming
- Single spatial stream / Standard throughput (e.g. IEEE 802.11™ [i.3] legacy mode)
- High Throughput (> 1 spatial stream) using Nominal Channel Bandwidth 1
- High Throughput (> 1 spatial stream) using Nominal Channel Bandwidth 2

NOTE 2: Add more lines if more channel bandwidths are supported.

h) In case of Smart Antenna Systems:

- The number of Receive chains:
- The number of Transmit chains:
 - symmetrical power distribution
 - asymmetrical power distribution

In case of beam forming, the maximum (additional) beam forming gain: dB

NOTE: The additional beam forming gain does not include the basic gain of a single antenna.

i) Operating Frequency Range(s) of the equipment:

- Operating Frequency Range 1: 2402 MHz to 2480 MHz
 - Operating Frequency Range 2: MHz to MHz
- NOTE: Add more lines if more Frequency Ranges are supported.

j) Nominal Channel Bandwidth(s):

- Nominal Channel Bandwidth 1: 1.196MHz (Left)
 - Nominal Channel Bandwidth 2: 1.194MHz (Right)
- NOTE: Add more lines if more channel bandwidths are supported.

k) Type of Equipment (stand-alone, combined, plug-in radio device, etc.):

- Stand-alone
- Combined Equipment (Equipment where the radio part is fully integrated within another type of equipment)
- Plug-in radio device (Equipment intended for a variety of host systems)
- Other

l) The normal and the extreme operating conditions that apply to the equipment:

Normal operating conditions (if applicable):

Operating temperature: 15°C~35°C
 Other (please specify if applicable):

Extreme operating conditions:

Operating temperature range: Minimum: -10°C Maximum 40°C
 Other (please specify if applicable): Minimum: Maximum

Details provided are for the:

- stand-alone equipment
- combined (or host) equipment
- test jig

m) The intended combination(s) of the radio equipment power settings and one or more antenna assemblies and their corresponding e.i.r.p. levels:

- Antenna Type: Chip antenna

Integral Antenna (information to be provided in case of conducted measurements)

Antenna Gain: 1.75 dBi

If applicable, additional beamforming gain (excluding basic antenna gain):/..... dB

- Temporary RF connector provided
- No temporary RF connector provided
- Dedicated Antennas (equipment with antenna connector)
- Single power level with corresponding antenna(s)
- Multiple power settings and corresponding antenna(s)

Number of different Power Levels:

Power Level 1: dBm

Power Level 2: dBm

Power Level 3: dBm

NOTE 1: Add more lines in case the equipment has more power levels.

NOTE 2: These power levels are conducted power levels (at antenna connector).

- For each of the Power Levels, provide the intended antenna assemblies, their corresponding gains (G) and the resulting e.i.r.p. levels also taking into account the beamforming gain (Y) if applicable

Power Level 1: dBm

Number of antenna assemblies provided for this power level:

Assembly #	Gain (dBi)	e.i.r.p. (dBm)	Part number or model name
Left	1.75	0.23	
Right	1.75	-1.57	

NOTE 3: Add more rows in case more antenna assemblies are supported for this power level.

Power Level 2: dBm

Number of antenna assemblies provided for this power level:

Assembly #	Gain (dBi)	e.i.r.p. (dBm)	Part number or model name
1			
2			
3			

NOTE 4: Add more rows in case more antenna assemblies are supported for this power level.

Power Level 3: dBm

Number of antenna assemblies provided for this power level:

Assembly #	Gain (dBi)	e.i.r.p. (dBm)	Part number or model name
1			
2			
3			

NOTE 5: Add more rows in case more antenna assemblies are supported for this power level.

n) The nominal voltages of the stand-alone radio equipment or the nominal voltages of the combined (host) equipment or test jig in case of plug-in devices:

Details provided are for the:

- stand-alone equipment
- combined (or host) equipment
- test jig

Supply Voltage AC mains State AC voltage V
 DC State DC voltage: DC 3.7V

In case of DC, indicate the type of power source

- Internal Power Supply
- External Power Supply or AC/DC adapter: DC 5V
- Battery: DC 3.7V
- Other:

o) Describe the test modes available which can facilitate testing:

See clause 1.4

p) The equipment type (e.g. Bluetooth®, IEEE 802.11™ [i.3], IEEE 802.15.4™ [i.4], proprietary, etc.):

Bluetooth®

q) If applicable, the statistical analysis referred to in clause 5.4.1 q)

(to be provided as separate attachment)

r) If applicable, the statistical analysis referred to in clause 5.4.1 r)

(to be provided as separate attachment)

s) Geo-location capability supported by the equipment:

- Yes
- The geographical location determined by the equipment as defined in clause 4.3.1.13.2 or clause 4.3.2.12.2 is not accessible to the user
- No

t) Describe the minimum performance criteria that apply to the equipment (see clause 4.3.1.12.3 or clause 4.3.2.11.3):

GFSK(CH00) =0.96% (Left)
 $\pi/4$ DQPSK (CH00) =0.96% (Right)

1.3 TEST CONDITIONS

	Normal Test Conditions	Extreme Test Conditions
Temperature	15°C - 35°C	-10°C ~ 40°C Note: (1)
Relative Humidity	20% - 75%	N/A
Supply Voltage	DC 3.7V	/

Note:

- (1) The HT 40°C and LT -10°C was declared by manufacturer, The EUT couldn't be operate normally with higher or lower temperature.
- (2) The measurements are performed at the highest, middle, lowest available channels.

1.4 TEST CONFIGURATION OF EUT

Modulation Used For Conformance Testing		
Bluetooth mode	Data rate	Modulation type
BR	1Mbps	GFSK
EDR	2Mbps	$\pi/4$ -DQPSK

Test Channel Frequencies Configuration		
Test Channel	EUT Channel	Test Frequency (MHz)
Lowest	CH00	2402
Middle	CH39	2441
Highest	CH78	2480

1.5 DESCRIPTION OF TEST CONDITIONS

E-1
EUT

1.6 DESCRIPTION OF SUPPORT UNITS

The EUT has been tested as an independent unit together with other necessary accessories or support units. The following support units or accessories were used to form a representative test configuration during the tests.

Item	Equipment	Model/Type No.	Series No.	Note
E-1	Wireless Earphone	AirBuds 10	N/A	EUT

Item	Shielded Type	Ferrite Core	Length	Note

Note:

- (1) The support equipment was authorized by Declaration of Confirmation.
- (2) For detachable type I/O cable should be specified the length in cm in 『Length』 column.

1.7 EQUIPMENTS LIST FOR ALL TEST ITEMS

EQUIPMENT TYPE	Manufacturer	Type No.	Serial No.	Last calibration	Calibrated until	Calibration period
EMI Test Receiver	R&S	ESPI7	101318	2022.04.06	2023.04.05	1 year
Bilog Antenna	TESEQ	CBL6111D	31216	2022.03.30	2023.03.29	1 year
Turn Table	EM	SC100_1	60531	N/A	N/A	N/A
Antenna Mast	EM	SC100	N/A	N/A	N/A	N/A
Horn Antenna	EM	EM-AH-10180	2011071402	2022.03.31	2023.03.30	1 year
Horn Ant	Schwarzbeck	BBHA 9170	9170-181	2022.04.01	2023.03.31	1 year
Test Cable (30MHz-1GHz)	N/A	R-01	N/A	2022.06.17	2025.06.16	3 year
Test Cable (1-18GHz)	N/A	R-02	N/A	2022.06.17	2025.06.16	3 year
50Ω Coaxial Switch	Anritsu	MP59B	6200983705	2020.05.11	2023.05.10	3 year
Pre-Amplifier	EMC	EMC051835SE	980246	2022.06.17	2023.06.16	1 year
Spectrum Analyzer	Agilent	E4407B	MY45108040	2022.04.01	2023.03.31	1 year
Filter	TRILTHIC	2400MHz	29	2020.04.07	2023.04.06	3 year
Attenuator	Weinschel	33-10-33	AR4010	2020.04.07	2023.04.06	3 year
Attenuator	Weinschel	24-20-34	BP4485	2020.04.07	2023.04.06	3 year
MXA Signal Analyzer	Agilent	N9020A	MY49100060	2022.06.17	2023.06.16	1 year
ESG VETCTOR SIGNAL GENERAROR	Agilent	E4438C	MY45093347	2022.04.01	2023.03.31	1 year
Power Splitter	Mini-Circuits/USA	ZN2PD-63-S+	SF025101428	2020.04.07	2023.04.06	3 year
Coupler	Mini-Circuits	ZADC-10-63-S +	SF794101410	2020.04.07	2023.04.06	3 year
Directional Coupler	MCLI/USA	CB11-20	0D2L51502	2020.07.17	2023.07.16	3 year
Attenuator	Agilent	8495B	MY42147029	2020.04.13	2023.04.12	3 year
Power Meter	DARE	RPR3006W	15I00041SNO 84	2022.06.17	2023.06.16	1 year
MXG Vector Signal Generator	Agilent	N5182A	MY47070317	2022.06.16	2023.06.15	1 year
Wideband Radio Communication Tester Specifications	R&S	CMW500	148500	2022.06.16	2023.06.15	1 year
temporary antenna connector (Note)	NTS	R001	N/A	N/A	N/A	N/A

2. SUMMARY OF TEST RESULTS

The EUT has been tested according to the following specifications:

ETSI EN 300 328 V2.2.2 (2019-07)		
Clause	Test Item	Results
TRANSMITTER PARAMETERS		
4.3.1.2	RF Output Power	Pass
4.3.1.3	Duty cycle, Tx-Sequence, Tx-gap	Not Applicable (See Note 1/2)
4.3.1.4	Accumulated Transmit Time, Frequency Occupation and Hopping Sequence	Pass
4.3.1.5	Hopping Frequency Separation	Pass
4.3.1.6	Medium Utilization (MU) factor	Not Applicable (See Note 1/2)
4.3.1.7	Adaptivity	Not Applicable (See Note 1)
4.3.1.8	Occupied Channel Bandwidth	Pass
4.3.1.9	Transmitter unwanted emission in the OOB domain	Pass
4.3.1.10	Transmitter unwanted emissions in the spurious domain	Pass
RECEIVER PARAMETERS		
4.3.1.11	Receiver Spurious Emissions	Pass
4.3.1.12	Receiver Blocking	Pass

Note:

1. These requirements do not apply for equipment with a maximum declared RF output power of less than 10 dBm EIRP or for equipment when operating in a mode where the RF output power is less than 10 dBm EIRP.
2. These requirements apply to non-adaptive frequency hopping equipment or to adaptive frequency hopping equipment operating in a non-adaptive mode
3. The antenna gain provided by customer is used to calculate the EIRP result. NTEK is not responsible for the accuracy of antenna gain parameter.

2.1 TEST FACILITY

Shenzhen NTEK Testing Technology Co., Ltd.
 Add. : 1/F, Building E, Fenda Science Park, Sanwei Community, Xixiang Street, Bao'an District, Shenzhen 518126 P.R. China
 FCC Registered No.: 463705 IC Registered No.:9270A-1
 CNAS Registration No.:L5516

2.2 MAXIMUM MEASUREMENT UNCERTAINTY

For the test methods, according to ETSI EN 300 328 standard, the measurement uncertainty figures shall be calculated in accordance with ETR 100 028-1[4] and shall correspond to an expansion factor(coverage factor) $k=1.96$ or $k=2$ (which provide confidence levels of respectively **95 %** and **95.45 %** in the case where the distributions characterizing the actual measurement uncertainties are normal (Gaussian)).

Maximum measurement uncertainty

No.	Item	Uncertainty
1	Occupied Channel Bandwidth	$\pm 5\%$
2	RF output Power,conducted	$\pm 1.5\text{dB}$
3	Power Spectral Density, conducted	$\pm 3\text{dB}$
4	Unwanted emissions, conducted	$\pm 3\text{dB}$
5	All emissions,radiated	$\pm 6\text{dB}$
6	Temperature	$\pm 3^\circ\text{C}$
7	Humidity	$\pm 3\%$
9	Time	$\pm 5\%$

TRANSMITTER PARAMETERS

3. RF OUTPUT POWER

3.1 LIMITS OF RF OUTPUT POWER

Refer to chapter 4.3.1.2.3 of ETSI EN 300 328 V2.2.2 (2019-07)

RF OUTPUT POWER	
Condition	Limit
<input type="checkbox"/> Non-adaptive frequency hopping systems	Equal to or less than the value declared by the supplier. This declared value shall be equal to or less than 20 dBm.
<input checked="" type="checkbox"/> Adaptive frequency hopping systems	equal to or less than 20 dBm.

3.2 TEST PROCEDURE

Refer to chapter 5.4.2.2 of ETSI EN 300 328 V2.2.2 (2019-07)

Measurement	
<input checked="" type="checkbox"/> Conducted measurement	<input type="checkbox"/> Radiated measurement

3.3 DEVIATION FROM TEST STANDARD

No deviation

3.4 TEST SETUP

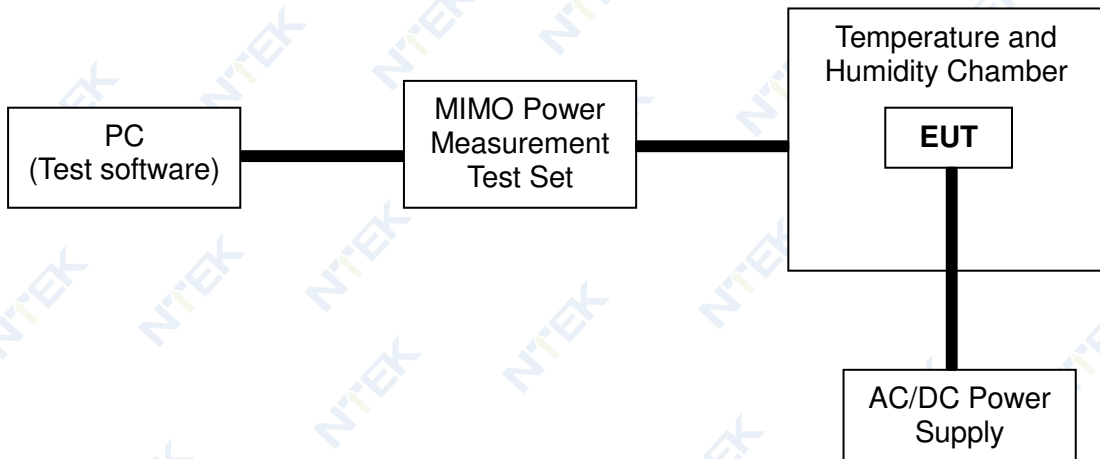

3.5 TEST RESULTS

EUT :	Wireless Earphone	Model Name :	AirBuds 10
Temperature :	20°C	Relative Humidity :	55 %
Pressure :	1012 hPa	Test Voltage :	DC 3.7V
Test Mode :	BT-GFSK/ π /4-DQPSK		

Test data reference attachment

4. ACCUMULATED TRANSMIT TIME, FREQUENCY OCCUPATION AND HOPPING SEQUENCE

4.1 LIMITS OF ACCUMULATED TRANSMIT TIME, FREQUENCY OCCUPATION AND HOPPING SEQUENCE

Refer to chapter 4.3.1.4.3 of ETSI EN 300 328 V2.2.2 (2019-07)

Accumulated Transmit Time	
Condition	Limit
<input type="checkbox"/> Non-adaptive frequency hopping systems	≤ 15 ms[15 ms * the minimum number of hopping frequencies (N)]
<input checked="" type="checkbox"/> Adaptive frequency hopping systems	≤ 400 ms in [400 ms * the minimum number of hopping frequencies (N)]
MINIMUM FREQUENCY OCCUPATION TIME	
Condition	Limit
<input type="checkbox"/> Non-adaptive frequency hopping systems	Each hopping frequency of the hopping sequence shall be occupied at least once within a period not exceeding four times the product of the dwell time and the number of hopping frequencies in use.
<input checked="" type="checkbox"/> Adaptive frequency hopping systems	
HOPPING SEQUENCE (S)	
Condition	Limit
<input type="checkbox"/> Non-adaptive frequency hopping systems	≥15 hopping frequencies or 15/minimum
<input checked="" type="checkbox"/> Adaptive frequency hopping systems	Operating over a minimum of 70% of the Operating in the band 2.4 GHz to 2.4835 GHz
	≥15 hopping frequencies or 15/minimum

4.2 TEST PROCEDURE

Refer to chapter 5.4.4 of ETSI EN 300 328 V2.2.2 (2019-07)

Measurement	
<input checked="" type="checkbox"/> Conducted measurement	<input type="checkbox"/> Radiated measurement

4.3 DEVIATION FROM TEST STANDARD

No deviation

4.4 TEST SETUP



The measurements only were performed at normal test conditions. The equipment was configured to operate at its maximum Dwell time and maximum Duty Cycle. The measurement was performed on a minimum of 2 hopping frequencies chosen arbitrary from the actual hopping sequence. In case of conducted measurements the transmitter shall be connected to the measuring equipment via a suitable attenuator. Controlling software (Button Function) has been activated to set the EUT on specific status.

4.5 TEST RESULTS

EUT :	Wireless Earphone	Model Name :	AirBuds 10
Temperature :	26°C	Relative Humidity	60 %
Pressure :	1012 hPa	Test Voltage :	DC 3.7V
Test Mode :	BT-GFSK/π/4-DQPSK -Hopping Mode		

Test data reference attachment

5. OCCUPIED CHANNEL BANDWIDTH

5.1 LIMITS OF OCCUPIED CHANNEL BANDWIDTH

Refer to chapter 4.3.1.8.3 of ETSI EN 300 328 V2.2.2 (2019-07)

OCCUPIED CHANNEL BANDWIDTH		
Condition		Limit
All types of equipment		Shall fall completely within the band 2400 to 2483.5 MHz
Additional requirement	For non-adaptive using wide band modulations other than FHSS system and EIRP >10 dBm	Less than 20 MHz
	For non-adaptive frequency hopping system and EIRP >10 dBm	Less than 5 MHz

5.2 TEST PROCEDURE

Refer to chapter 5.4.7.2 of ETSI EN 300 328 V2.2.2 (2019-07)

Measurement	
<input checked="" type="checkbox"/> Conducted measurement	<input type="checkbox"/> Radiated measurement

The setting of the Spectrum Analyzer

Center Frequency	The centre frequency of the channel under test
Frequency Span	2 × Nominal Channel Bandwidth
Detector	RMS
RBW	~ 1 % of the span without going below 1 %
VBW	3 × RBW
Trace	Max hold
Sweep time	1s

5.3 DEVIATION FROM TEST STANDARD

No deviation

5.4 TEST SETUP



These measurements only were performed at normal test conditions. The measurement shall be performed only on the lowest and the highest frequency within the ststed frequency range. Using software to force the EUT to hop or transmit on a single Hopping frequency. In case of conducted measurements the transmitter shall be connected to the measuring equipment via a suitable attenuator. Controlling software (Button Function) has been activated to set the EUT on specific status.

5.5 TEST RESULTS

EUT :	Wireless Earphone	Model Name :	AirBuds 10
Temperature :	26°C	Relative Humidity :	60 %
Pressure :	1012 hPa	Test Voltage :	DC 3.7V
Test Mode :	BT-GFSK/π/4-DQPSK -(CH00/CH78)		

Test data reference attachment

6. TRANSMITTER UNWANTED EMISSIONS IN THE OUT-OF-BAND DOMAIN

6.1 LIMITS OF TRANSMITTER UNWANTED EMISSIONS IN THE OUT-OF-BAND DOMAIN

Refer to chapter 4.3.1.9.3 of ETSI EN 300 328 V2.2.2 (2019-07)

TRANSMITTER UNWANTED EMISSIONS IN THE OUT-OF-BAND DOMAIN	
Condition	Limit
Under all test conditions	The transmitter unwanted emissions in the out-of-band domain but outside the allocated band, shall not exceed the values provided by the mask in below figure.

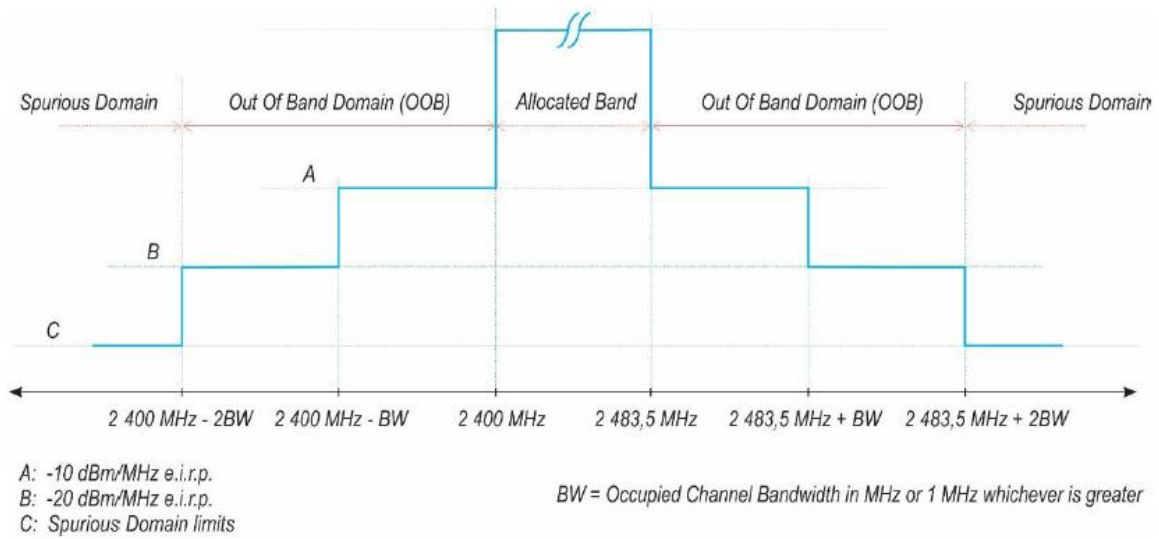

Figure 1: Transmit mask

6.2 TEST PROCEDURE

Refer to chapter 5.4.8.2 of ETSI EN 300 328 V2.2.2 (2019-07)

Measurement	
<input checked="" type="checkbox"/> Conducted measurement	<input type="checkbox"/> Radiated measurement

The setting of the Spectrum Analyzer

Span	0Hz
Filter Mode	Channel Filter
Trace Mode	Clear/Write
Trigger Mode	Video Trigger
Detector	RMS
Sweep Point / Sweep Mode	5000 / Continuous
RBW / VBW	1MHz / 3MHz

6.3 DEVIATION FROM TEST STANDARD

No deviation

6.4 TEST SETUP

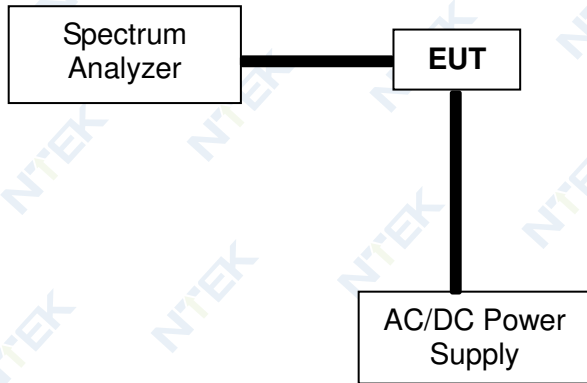

According to the ETSI EN 300328 V2.2.2 clause 5.4.8.1: These measurements shall only be performed at normal test conditions. For equipment using FHSS modulation, the measurements shall be performed during normal operation (hopping).

For equipment using wide band modulations other than FHSS, the measurement shall be performed at the lowest and the highest channel on which the equipment can operate. These operating channels shall be recorded.

The equipment shall be configured to operate under its worst case situation with respect to output power.

If the equipment can operate with different Nominal Channel Bandwidths (e.g. 20 MHz and 40 MHz), then each channel bandwidth shall be tested separately.

6.5 TEST RESULTS

EUT :	Wireless Earphone	Model Name :	AirBuds 10
Temperature :	26°C	Relative Humidity :	60 %
Pressure :	1012 hPa	Test Voltage :	DC 3.7V
Test Mode :	BT-GFSK/π/4-DQPSK -(CH78)		

Test data reference attachment

7. HOPPING FREQUENCY SEPARATION

7.1 LIMITS OF HOPPING FREQUENCY SEPARATION

Refer to chapter 4.3.1.5.3 of ETSI EN 300 328 V2.2.2 (2019-07)

HOPPING FREQUENCY SEPARATION	
Condition	Limit
<input type="checkbox"/> Non-adaptive frequency hopping systems	The minimum Hopping Frequency Separation shall be equal to or greater than occupied channel bandwidth of a single hop, with a minimum separation of 100 kHz.
<input checked="" type="checkbox"/> Adaptive frequency hopping systems	The minimum Hopping Frequency Separation shall be 100 kHz.

7.2 TEST PROCEDURE

Refer to chapter 5.4.5.2 of ETSI EN 300 328 V2.2.2 (2019-07)

Measurement	
<input checked="" type="checkbox"/> Conducted measurement	<input type="checkbox"/> Radiated measurement

The setting of the Spectrum Analyzer

Center Frequency	Centre of the two adjacent hopping frequencies
Frequency Span	Sufficient to see the complete power envelope of both hopping frequencies
Detector	Max Peak
RBW	~ 1 % of the span
VBW	3 × RBW
Trace	Max hold
Sweep Time	Auto

7.3 DEVIATION FROM TEST STANDARD

No deviation

7.4 TEST SETUP



The measurements were performed at normal test conditions. The measurement was performed on 2 adjacent hopping frequencies. In case of conducted measurements the transmitter shall be connected to the measuring equipment via a suitable attenuator. Controlling software (Button Function) has been activated to set the EUT on specific status.

7.5 TEST RESULTS

EUT :	Wireless Earphone	Model Name :	AirBuds 10
Temperature :	26°C	Relative Humidity :	60 %
Pressure :	1012 hPa	Test Voltage :	DC 3.7V
Test Mode :	BT-GFSK/π/4-DQPSK -(CH00/CH39/CH78)		

Test data reference attachment

- Note: 1.The limitation is from OCB of a single hop and this value must greater and equal to 100kHz.
 2.The device will never “hop” to its neighbour channel, therefore the “effective” channel separation becomes 2x the “normal” channel separation.

8. TRANSMITTER UNWANTED EMISSIONS IN THE SPURIOUS DOMAIN

8.1 LIMITS OF TRANSMITTER TRANSMITTER UNWANTED EMISSIONS IN THE SPURIOUS DOMAIN

Refer to chapter 4.3.1.10.3 of ETSI EN 300 328 V2.2.2 (2019-07)

TRANSMITTER UNWANTED EMISSIONS IN THE SPURIOUS DOMAIN		
Frequency Range	Maximum Power Limit (E.R.P.(≤1 GHz) E.I.R.P.(> 1 GHz))	Bandwidth
30 MHz to 47 MHz	-36dBm	100 kHz
47 MHz to 74 MHz	-54dBm	100 kHz
74 MHz to 87.5 MHz	-36dBm	100 kHz
87.5 MHz to 118 MHz	-54dBm	100 kHz
118 MHz to 174 MHz	-36dBm	100 kHz
174 MHz to 230 MHz	-54dBm	100 kHz
230 MHz to 470 MHz	-36dBm	100 kHz
470 MHz to 694 MHz	-54dBm	100 kHz
694 MHz to 1 GHz	-36dBm	100 kHz
1 GHz ~ 12.75 GHz	-30dBm	1 MHz

8.2 TEST PROCEDURE

Refer to chapter 5.4.9.2 of ETSI EN 300 328 V2.2.2 (2019-07)

Measurement	
<input checked="" type="checkbox"/> Conducted measurement	<input checked="" type="checkbox"/> Radiated measurement

The setting of the Spectrum Analyzer

RBW	100K(<1GHz) / 1M(>1GHz)
VBW	300K(<1GHz) / 3M(>1GHz)

8.3 DEVIATION FROM TEST STANDARD

No deviation

8.4 TEST SETUP

Radiated measurement:

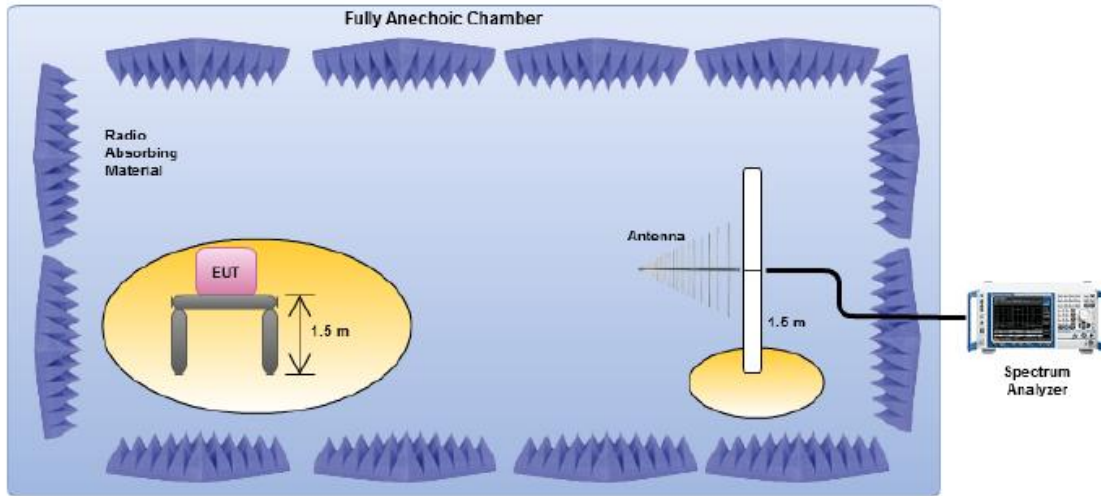

Conducted measurement:



1. For the actual test configuration, please refer to the related Item in this test report (Photographs of the Test Configuration).
2. The measurements were performed when normal hopping was disabled. In this case measurements were performed when operating at the lowest and the highest hopping frequency.
3. The equipment was configured to operate under its worst case situation with respect to output power.
4. The test setup has been constructed as the normal use condition. Controlling software (Button Function) has been activated to set the EUT on specific status.

8.5 TEST RESULTS (Radiated measurement)
BELOW 1 GHz WORST- CASE DATA (30 MHz ~ 1GHz)

EUT :	Wireless Earphone	Model Name :	AirBuds 10
Temperature :	24 °C	Relative Humidity	54%
Pressure :	1010 hPa	Test Power :	DC 3.7V
Test Mode :	BT-GFSK (CH00)		

Left

Polar (H/V)	Frequency	Meter Reading	Factor	Emission Level	Limits	Margin	Remark
	(MHz)	(dBm)	(dB)	(dBm)	(dBm)	(dB)	
V	46.8663	-82.08	16.22	-65.86	-36	-29.86	peak
V	116.496	-80.13	14.71	-65.42	-54	-11.42	peak
V	209.8266	-82.84	12.67	-70.17	-54	-16.17	peak
V	456.211	-86.47	14.64	-71.83	-36	-35.83	peak
V	494.5887	-82.6	12.98	-69.62	-54	-15.62	peak
V	703.7657	-85.91	14.48	-71.43	-36	-35.43	peak
H	41.9812	-77.51	19.90	-57.61	-36	-21.61	peak
H	114.7743	-78.34	13.65	-64.69	-54	-10.69	peak
H	223.2427	-86.56	14.28	-72.28	-54	-18.28	peak
H	245.2828	-84.75	14.56	-70.19	-36	-34.19	peak
H	452.1218	-77.75	15.81	-61.94	-36	-25.94	peak
H	819.8235	-81.78	14.48	-67.30	-36	-31.30	peak

Remark:

1. Emission Level= Meter Reading+ Factor, Margin= Limit- Emission Level.
2. All the modes had been tested, but only the worst data recorded in the report.

Right

Polar (H/V)	Frequency	Meter Reading	Factor	Emission Level	Limits	Margin	Remark
	(MHz)	(dBm)	(dB)	(dBm)	(dBm)	(dB)	
V	34.0178	-83.74	17.32	-66.42	-36	-30.42	peak
V	96.1453	-85.93	15.32	-70.61	-54	-16.61	peak
V	205.8274	-87.66	14.21	-73.45	-54	-19.45	peak
V	301.3266	-85	17.21	-67.79	-36	-31.79	peak
V	503.429	-87.88	15.92	-71.96	-54	-17.96	peak
V	737.1765	-83.84	17.32	-66.52	-36	-30.52	peak
H	32.1629	-80.19	16.81	-63.38	-36	-27.38	peak
H	93.2201	-82.54	15.62	-66.92	-54	-12.92	peak
H	177.9442	-84.69	15.13	-69.56	-54	-15.56	peak
H	434.837	-86.86	15.45	-71.41	-36	-35.41	peak
H	309.6106	-85.71	18.31	-67.40	-36	-31.40	peak
H	822.2497	-84.63	17.11	-67.52	-36	-31.52	peak

Remark:

1. Emission Level= Meter Reading+ Factor, Margin= Limit- Emission Level.
2. All the modes had been tested, but only the worst data recorded in the report.

ABOVE 1 GHz WORST- CASE DATA (1GHz ~ 12.75GHz)

EUT :	Wireless Earphone	Model Name :	AirBuds 10
Temperature :	24 °C	Relative Humidity	54%
Pressure :	1010 hPa	Test Power :	DC 3.7V
Test Mode :	GFSK (CH00/CH39/CH78)		

Left

Polar (H/V)	Frequency	Meter Reading	Factor	Emission Level	Limits	Margin	Remark
	(MHz)	(dBm)	(dB)	(dBm)	(dBm)	(dB)	
operation frequency:2402							
V	4804.520	-66.10	25.63	-40.47	-30	-10.47	peak
V	7206.830	-70.20	29.83	-40.37	-30	-10.37	peak
H	4804.520	-69.70	25.63	-44.07	-30	-14.07	peak
H	7206.830	-69.80	29.83	-39.97	-30	-9.97	peak
operation frequency:2441							
V	4882.610	-72.70	26.62	-46.08	-30	-16.08	peak
V	7324.850	-70.60	29.64	-40.96	-30	-10.96	peak
H	4882.610	-71.40	26.62	-44.78	-30	-14.78	peak
H	7324.850	-73.40	29.64	-43.76	-30	-13.76	peak
operation frequency:2480							
V	4961.700	-66.40	27.49	-38.91	-30	-8.91	peak
V	7440.770	-72.40	29.82	-42.58	-30	-12.58	peak
H	4961.700	-72.00	27.49	-44.51	-30	-14.51	peak
H	7440.770	-72.70	29.82	-42.88	-30	-12.88	peak

Remark:

1. Emission Level= Meter Reading+ Factor, Margin= Limit- Emission Level.
2. All the modes had been tested, but only the worst data recorded in the report.

Right

Polar (H/V)	Frequency	Meter Reading	Factor	Emission Level	Limits	Margin	Remark
	(MHz)	(dBm)	(dB)	(dBm)	(dBm)	(dB)	
operation frequency:2402							
V	4804.05	-66.10	25.63	-40.47	-30	-10.47	peak
V	7206.22	-75.10	29.83	-45.27	-30	-15.27	peak
H	4804.05	-73.70	25.63	-48.07	-30	-18.07	peak
H	7206.22	-71.70	29.83	-41.87	-30	-11.87	peak
operation frequency:2441							
V	4882.58	-75.10	26.62	-48.48	-30	-18.48	peak
V	7324.5	-76.10	29.64	-46.46	-30	-16.46	peak
H	4882.58	-71.00	26.62	-44.38	-30	-14.38	peak
H	7324.5	-79.40	29.64	-49.76	-30	-19.76	peak
operation frequency:2480							
V	4961.84	-71.30	27.49	-43.81	-30	-13.81	peak
V	7440.99	-74.40	29.82	-44.58	-30	-14.58	peak
H	4961.84	-66.20	27.49	-38.71	-30	-8.71	peak
H	7440.99	-74.60	29.82	-44.78	-30	-14.78	peak
Remark:							
1. Emission Level= Meter Reading+ Factor, Margin= Limit- Emission Level.							
2. All the modes had been tested, but only the worst data recorded in the report.							

8.6 TEST RESULTS (Conducted measurement)

Test data reference attachment

9. RECEIVER SPURIOUS EMISSIONS

9.1 LIMITS OF RECEIVER SPURIOUS RADIATION

Refer to chapter 4.3.1.11.3 of ETSI EN 300 328 V2.2.2 (2019-07)

RECEIVER SPURIOUS EMISSIONS		
Frequency Range	Maximum Power Limit (E.R.P.(≤1 GHz) E.I.R.P.(> 1 GHz))	Measurement Bandwidth
30 MHz ~ 1 GHz	-57dBm	100KHz
1 GHz ~ 12.75 GHz	-47dBm	1MHz

9.2 TEST PROCEDURE

Refer to chapter 5.4.10.2 of ETSI EN 300 328 V2.2.2 (2019-07)

Measurement	
<input checked="" type="checkbox"/> Conducted measurement	<input checked="" type="checkbox"/> Radiated measurement

The setting of the Spectrum Analyzer

RBW	100K(<1GHz) / 1M(>1GHz)
VBW	300K(<1GHz) / 3M(>1GHz)

9.3 DEVIATION FROM TEST STANDARD

No deviation

9.4 TEST SETUP

Radiated measurement:

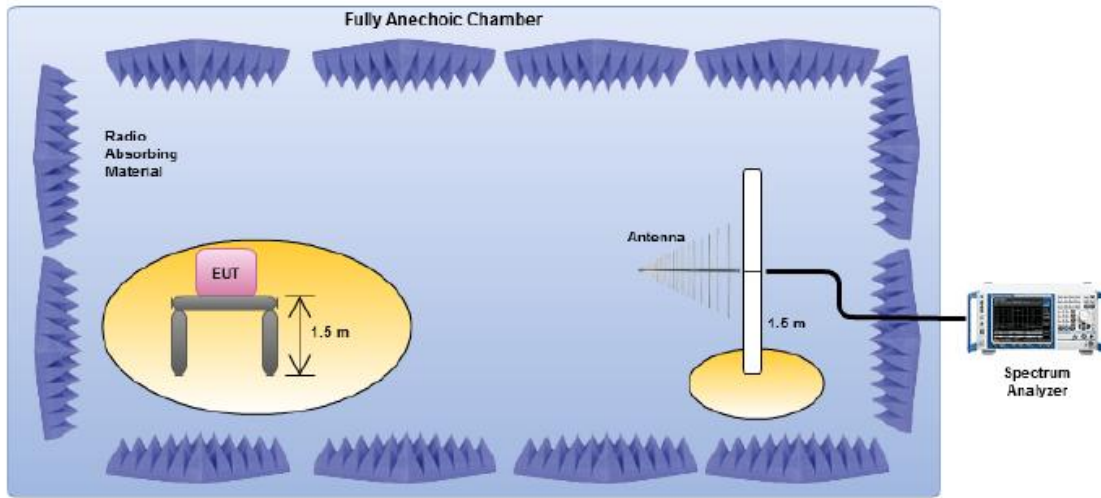

Conducted measurement:

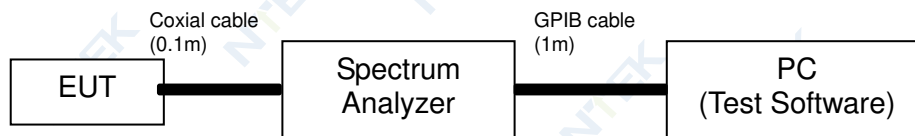

1. For the actual test configuration, please refer to the related Item in this test report (Photographs of the Test Configuration).
2. Testing was performed when the equipment was in a receive-only mode.
3. The measurements were performed when normal hopping was disabled. In this case measurements were performed when operating at the lowest and the highest hopping frequency.
4. The test setup has been constructed as the normal use condition. Controlling software (Button Function) has been activated to set the EUT on specific status.

9.5 TEST RESULTS (Radiated measurement)

RX BELOW 1 GHz WORST- CASE DATA (30 MHz ~ 1GHz)

EUT :	Wireless Earphone	Model Name :	AirBuds 10
Temperature :	24 °C	Relative Humidity	54%
Pressure :	1010 hPa	Test Power :	DC 3.7V
Test Mode :	GFSK(CH00)		

Left

Polar (H/V)	Frequency	Meter Reading	Factor	Emission Level	Limits	Margin	Remark
	(MHz)	(dBm)	(dB)	(dBm)	(dBm)	(dB)	
V	32.9995	-79.11	16.13	-62.98	-57	-5.98	peak
V	105.675	-87.05	14.82	-72.23	-57	-15.23	peak
V	178.5842	-89.54	22.09	-67.45	-57	-10.45	peak
V	442.2866	-83.35	14.80	-68.55	-57	-11.55	peak
V	496.2673	-89.72	13.40	-76.32	-57	-19.32	peak
V	752.7719	-81.46	14.60	-66.86	-57	-9.86	peak
H	36.264	-84.93	21.75	-63.18	-57	-6.18	peak
H	114.3233	-86.53	21.26	-65.27	-57	-8.27	peak
H	213.7413	-88.43	13.45	-74.98	-57	-17.98	peak
H	352.557	-83.87	18.15	-65.72	-57	-8.72	peak
H	606.2867	-87.7	16.78	-70.92	-57	-13.92	peak
H	716.2182	-89.71	17.78	-71.93	-57	-14.93	peak

Remark:

1. Emission Level= Meter Reading+ Factor, Margin= Limit- Emission Level.
2. All the modes had been tested, but only the worst data recorded in the report.

Right

Polar (H/V)	Frequency	Meter Reading	Factor	Emission Level	Limits	Margin	Remark
	(MHz)	(dBm)	(dB)	(dBm)	(dBm)	(dB)	
V	44.7829	-87.27	13.98	-73.29	-57	-16.29	peak
V	90.706	-83.37	12.26	-71.11	-57	-14.11	peak
V	194.7027	-88.82	13.94	-74.88	-57	-17.88	peak
V	429.7235	-89.73	14.65	-75.08	-57	-18.08	peak
V	554.2137	-87.1	16.23	-70.87	-57	-13.87	peak
V	750.2688	-79.87	14.12	-65.75	-57	-8.75	peak
H	38.2664	-85.39	13.26	-72.13	-57	-15.13	peak
H	107.8301	-81.62	15.13	-66.49	-57	-9.49	peak
H	216.8004	-81.11	13.30	-67.81	-57	-10.81	peak
H	286.2748	-88.74	18.00	-70.74	-57	-13.74	peak
H	618.457	-83.66	16.63	-67.03	-57	-10.03	peak
H	728.1512	-86.13	17.63	-68.50	-57	-11.50	peak

Remark:

1. Emission Level= Meter Reading+ Factor, Margin= Limit- Emission Level.
2. All the modes had been tested, but only the worst data recorded in the report.

RX ABOVE 1 GHz WORST- CASE DATA (1GHz ~ 12.75GHz)

EUT :	Wireless Earphone	Model Name :	AirBuds 10
Temperature :	24 °C	Relative Humidity	54%
Pressure :	1010 hPa	Test Power :	DC 3.7V
Test Mode :	GFSK (CH00)		

Left

Polar (H/V)	Frequency	Meter Reading	Factor	Emission Level	Limits	Margin	Remark
	(MHz)	(dBm)	(dB)	(dBm)	(dBm)	(dB)	
V	1948.185	-83.73	18.94	-64.79	-47	-17.79	peak
V	2397.104	-85.65	18.82	-66.83	-47	-19.83	peak
V	3000.765	-89.87	19.02	-70.85	-47	-23.85	peak
V	4417.29	-86.98	20.13	-66.85	-47	-19.85	peak
V	4852.159	-87.9	22.16	-65.74	-47	-18.74	peak
V	5559.619	-91.27	25.19	-66.08	-47	-19.08	peak
H	2604.44	-88.86	19.11	-69.75	-47	-22.75	peak
H	2916.635	-91.34	19.68	-71.66	-47	-24.66	peak
H	3305.976	-87.9	19.21	-68.69	-47	-21.69	peak
H	3695.649	-85.08	20.23	-64.85	-47	-17.85	peak
H	4471.047	-91.02	17.60	-73.42	-47	-26.42	peak
H	5869.616	-85.82	23.56	-62.26	-47	-15.26	peak

1. Emission Level= Meter Reading+ Factor, Margin= Limit- Emission Level.
2. All the modes had been tested, but only the worst data recorded in the report.

Right

Polar (H/V)	Frequency	Meter Reading	Factor	Emission Level	Limits	Margin	Remark
	(MHz)	(dBm)	(dB)	(dBm)	(dBm)	(dB)	
V	1512.81	-83.09	17.09	-66.00	-47	-19.00	peak
V	2793.145	-84.93	18.02	-66.91	-47	-19.91	peak
V	3803.692	-84.91	19.12	-65.79	-47	-18.79	peak
V	4418.813	-86.60	19.28	-67.32	-47	-20.32	peak
V	4839.435	-86.10	22.34	-63.76	-47	-16.76	peak
V	5626.723	-83.32	24.69	-58.63	-47	-11.63	peak
H	2249.463	-87.70	13.22	-74.48	-47	-27.48	peak
H	2899.393	-83.30	13.81	-69.49	-47	-22.49	peak
H	3159.114	-86.46	13.33	-73.13	-47	-26.13	peak
H	3557.338	-81.05	14.28	-66.77	-47	-19.77	peak
H	4376.447	-85.17	15.57	-69.60	-47	-22.60	peak
H	5434.641	-86.12	21.71	-64.41	-47	-17.41	peak

1. Emission Level= Meter Reading+ Factor, Margin= Limit- Emission Level.
2. All the modes had been tested, but only the worst data recorded in the report.

9.6 TEST RESULTS (Conducted measurement)

Test data reference attachment

10. RECEIVER BLOCKING

10.1 PERFORMANCE CRITERIA

The minimum performance criterion shall be a PER less than or equal to 10 %. The manufacturer may declare alternative performance criteria as long as that is appropriate for the intended use of the equipment (see clause 5.4.1.t)).

10.2 LIMITS OF RECEIVER BLOCKING

While maintaining the minimum performance criteria as defined in clause 4.3.1.12.3, the blocking levels at specified frequency offsets shall be equal to or greater than the limits defined for the applicable receiver category provided in table 6, table 7 or table 8.

Table 6: Receiver Blocking parameters for Receiver Category 1 equipment

Wanted signal mean power from companion device (dBm) (see notes 1 and 4)	Blocking signal Frequency (MHz)	Blocking signal power (dBm) (see note 4)	Type of blocking signal
(-133 dBm + 10 × log ₁₀ (OCBW)) or -68 dBm whichever is less (see note 2)	2 380	-34	CW
	2 504		
(-139 dBm + 10 × log ₁₀ (OCBW)) or -74 dBm whichever is less (see note 3)	2 300		
	2 330		
	2 360		
	2524		
	2584		
	2674		

NOTE 1: OCBW is in Hz.

NOTE 2: In case of radiated measurements using a companion device and the level of the wanted signal from the companion device cannot be determined, a relative test may be performed using a wanted signal up to P_{min} + 26 dB where P_{min} is the minimum level of wanted signal required to meet the minimum performance criteria as defined in clause 4.3.1.12.3 in the absence of any blocking signal.

NOTE 3: In case of radiated measurements using a companion device and the level of the wanted signal from the companion device cannot be determined, a relative test may be performed using a wanted signal up to P_{min} + 20 dB where P_{min} is the minimum level of wanted signal required to meet the minimum performance criteria as defined in clause 4.3.1.12.3 in the absence of any blocking signal.

NOTE 4: The level specified is the level at the UUT receiver input assuming a 0 dBi antenna assembly gain. In case of conducted measurements, this level has to be corrected for the (in-band) antenna assembly gain (G). In case of radiated measurements, this level is equivalent to a power flux density (PFD) in front of the UUT antenna with the UUT being configured/positioned as recorded in clause 5.4.3.2.2.

Table 7: Receiver Blocking parameters receiver category 2 equipment

Wanted signal mean power from companion device (dBm) (see notes 1 and 3)	Blocking signal Frequency (MHz)	Blocking signal power (dBm) (see note 3)	Type of blocking signal
(-139 dBm + 10 × log ₁₀ (OCBW) + 10 dB) or (-74 dBm + 10 dB) whichever is less (see note 2)	2 380	-34	CW
	2 504		
	2 300		
	2 584		

NOTE 1: OCBW is in Hz.

NOTE 2: In case of radiated measurements using a companion device and the level of the wanted signal from the companion device cannot be determined, a relative test may be performed using a wanted signal up to P_{min} + 26 dB where P_{min} is the minimum level of wanted signal required to meet the minimum performance criteria as defined in clause 4.3.1.12.3 in the absence of any blocking signal.

NOTE 3: The level specified is the level at the UUT receiver input assuming a 0 dBi antenna assembly gain. In case of conducted measurements, this level has to be corrected for the (in-band) antenna assembly gain (G). In case of radiated measurements, this level is equivalent to a power flux density (PFD) in front of the UUT antenna with the UUT being configured/positioned as recorded in clause 5.4.3.2.2.

Table 8: Receiver Blocking parameters receiver category 3 equipment

Wanted signal mean power from companion device (dBm)	Blocking signal Frequency (MHz)	Blocking signal power (dBm) (see note 2)	Type of blocking signal
(-139 dBm + 10 × log ₁₀ (OCBW) + 20 dB) or (-74 dBm + 20 dB) whichever is less (see note 2)	2 380	-34	CW
	2 504		
	2 300		
	2 584		

NOTE 1: OCBW is in Hz.

NOTE 2: In case of radiated measurements using a companion device and the level of the wanted signal from the companion device cannot be determined, a relative the test may be performed using a wanted signal up to P_{min} + 30 dB where P_{min} is the minimum level of wanted signal required to meet the minimum performance criteria as defined in clause 4.3.1.12.3 in the absence of any blocking signal.

NOTE 3: The level specified is the level at the UUT receiver input assuming a 0 dBi antenna assembly gain. In case of conducted measurements, this level has to be corrected for the (in-band) antenna assembly gain (G). In case of radiated measurements, this level is equivalent to a power flux density (PFD) in front of the UUT antenna with the UUT being configured/positioned as recorded in clause 5.4.3.2.2.

10.3 TEST PROCEDURE

Refer to chapter 5.4.11.2 of ETSI EN 300 328 V2.2.2 (2019-07)

Measurement	
<input checked="" type="checkbox"/> Conducted measurement	<input type="checkbox"/> Radiated measurement

10.4 DEVIATION FROM TEST STANDARD

No deviation

10.5 TEST SETUP

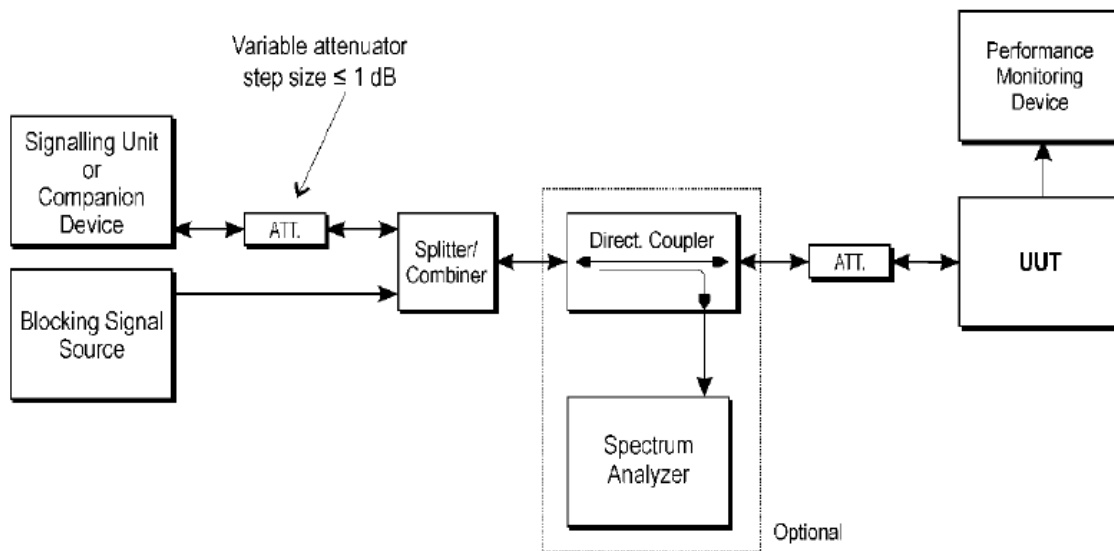

10.6 TEST RESULTS

EUT :	Wireless Earphone	Model Name :	AirBuds 10
Temperature :	24 °C	Relative Humidity	54%
Pressure :	1010 hPa	Test Power :	DC 3.7V
Test Mode :	GFSK Hopping mode (RX)- Left		

CH00

receiver category 2

Wanted signal mean power from companion device (dBm) (see notes 1 and 3)	Blocking signal Frequency (MHz)	Blocking signal power(dBm) (see note 3)	PER %	PER Limit %
-69.49	2 380	-34	0.96%	≤10
	2 504		0.23%	
	2 300		0.63%	≤10
	2 584		0.37%	

CH78

receiver category 3

Wanted signal mean power from companion device (dBm) (see notes 1 and 3)	Blocking signal Frequency (MHz)	Blocking signal power(dBm) (see note 3)	PER %	PER Limit %
-59.45	2 380	-34	0.82%	≤10
	2 504		0.88%	
	2 300		0.76%	≤10
	2 584		0.67%	

Note: (1) The above results were obtained from laboratory tests.

EUT :	Wireless Earphone	Model Name :	AirBuds 10
Temperature :	24 °C	Relative Humidity	54%
Pressure :	1010 hPa	Test Power :	DC 3.7V
Test Mode :	π/4 DQPSK Hopping mode (RX)- Left		

CH00

receiver category 3

Wanted signal mean power from companion device (dBm) (see notes 1 and 3)	Blocking signal Frequency (MHz)	Blocking signal power(dBm) (see note 3)	PER %	PER Limit %
-58.22	2 380	-34	0.56%	≤10
	2 504		0.76%	
	2 300		0.40%	≤10
	2 584		0.10%	

CH78

receiver category 3

Wanted signal mean power from companion device (dBm) (see notes 1 and 3)	Blocking signal Frequency (MHz)	Blocking signal power(dBm) (see note 3)	PER %	PER Limit %
-58.26	2 380	-34	0.52%	≤10
	2 504		0.89%	
	2 300		0.57%	≤10
	2 584		0.47%	

Note: (1) The above results were obtained from laboratory tests.

EUT :	Wireless Earphone	Model Name :	AirBuds 10
Temperature :	24 °C	Relative Humidity	54%
Pressure :	1010 hPa	Test Power :	DC 3.7V
Test Mode :	GFSK Hopping mode (RX) - Right		

CH00

receiver category 3

Wanted signal mean power from companion device (dBm) (see notes 1 and 3)	Blocking signal Frequency (MHz)	Blocking signal power(dBm) (see note 3)	PER %	PER Limit %
-59.53	2 380	-34	0.09%	≤10
	2 504		0.85%	
	2 300		0.24%	≤10
	2 584		0.72%	

CH78

receiver category 3

Wanted signal mean power from companion device (dBm) (see notes 1 and 3)	Blocking signal Frequency (MHz)	Blocking signal power(dBm) (see note 3)	PER %	PER Limit %
-59.47	2 380	-34	0.38%	≤10
	2 504		0.68%	
	2 300		0.57%	≤10
	2 584		0.90%	

Note: (1) The above results were obtained from laboratory tests.

EUT :	Wireless Earphone	Model Name :	AirBuds 10
Temperature :	24 °C	Relative Humidity	54%
Pressure :	1010 hPa	Test Power :	DC 3.7V
Test Mode :	π/4 DQPSK Hopping mode (RX)- Right		

CH00

receiver category 3

Wanted signal mean power from companion device (dBm) (see notes 1 and 3)	Blocking signal Frequency (MHz)	Blocking signal power(dBm) (see note 3)	PER %	PER Limit %
-58.23	2 380	-34	0.85%	≤10
	2 504		0.93%	
	2 300		0.03%	≤10
	2 584		0.49%	

CH78

receiver category 3

Wanted signal mean power from companion device (dBm) (see notes 1 and 3)	Blocking signal Frequency (MHz)	Blocking signal power(dBm) (see note 3)	PER %	PER Limit %
-58.26	2 380	-34	0.82%	≤10
	2 504		0.96%	
	2 300		0.55%	≤10
	2 584		0.37%	

Note: (1) The above results were obtained from laboratory tests.

11. TEST RESULTS

Left

11.1 Accumulated Transmit Time

Condition	Mode	Frequency (MHz)	Antenna	Accumulated Transmit Time (ms)	Limit (ms)	Sweep Time (ms)	Burst Number	Verdict
NVNT	1-DH1	2402	Ant1	122.56	400	31600	320	Pass
NVNT	1-DH1	2480	Ant1	122.177	400	31600	319	Pass
NVNT	1-DH3	2402	Ant1	283.72	400	31600	173	Pass
NVNT	1-DH3	2480	Ant1	265.68	400	31600	162	Pass
NVNT	1-DH5	2402	Ant1	303.45	400	31600	105	Pass
NVNT	1-DH5	2480	Ant1	314.683	400	31600	109	Pass
NVNT	2-DH1	2402	Ant1	124.264	400	31600	317	Pass
NVNT	2-DH1	2480	Ant1	124.656	400	31600	318	Pass
NVNT	2-DH3	2402	Ant1	253.89	400	31600	155	Pass
NVNT	2-DH3	2480	Ant1	251.532	400	31600	153	Pass
NVNT	2-DH5	2402	Ant1	294.984	400	31600	102	Pass
NVNT	2-DH5	2480	Ant1	294.984	400	31600	102	Pass

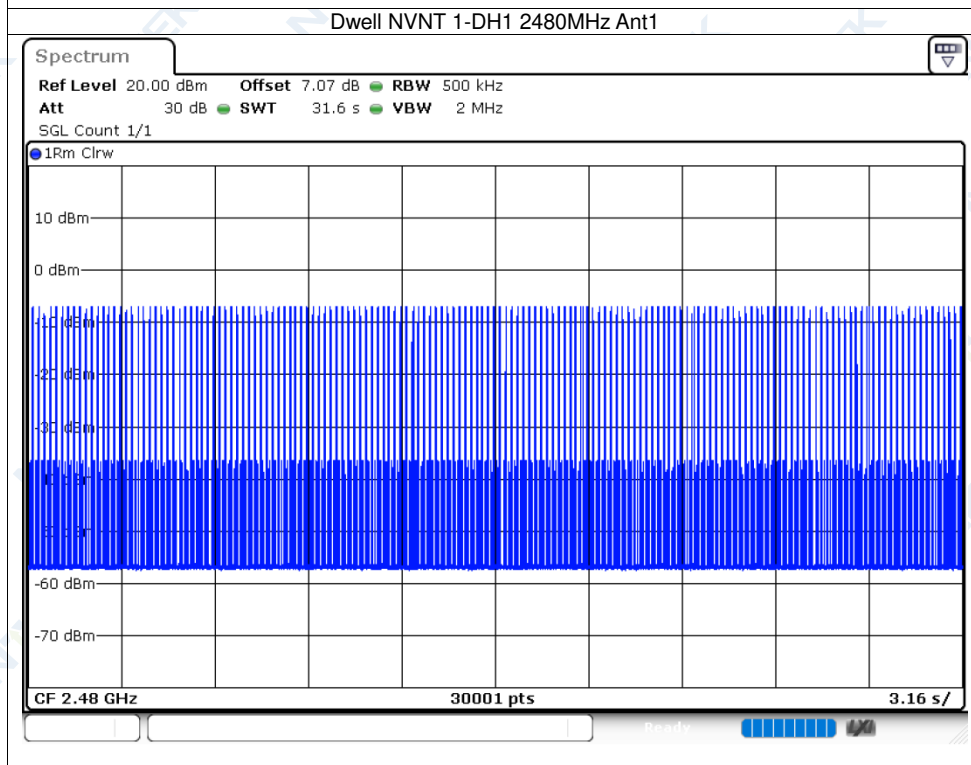
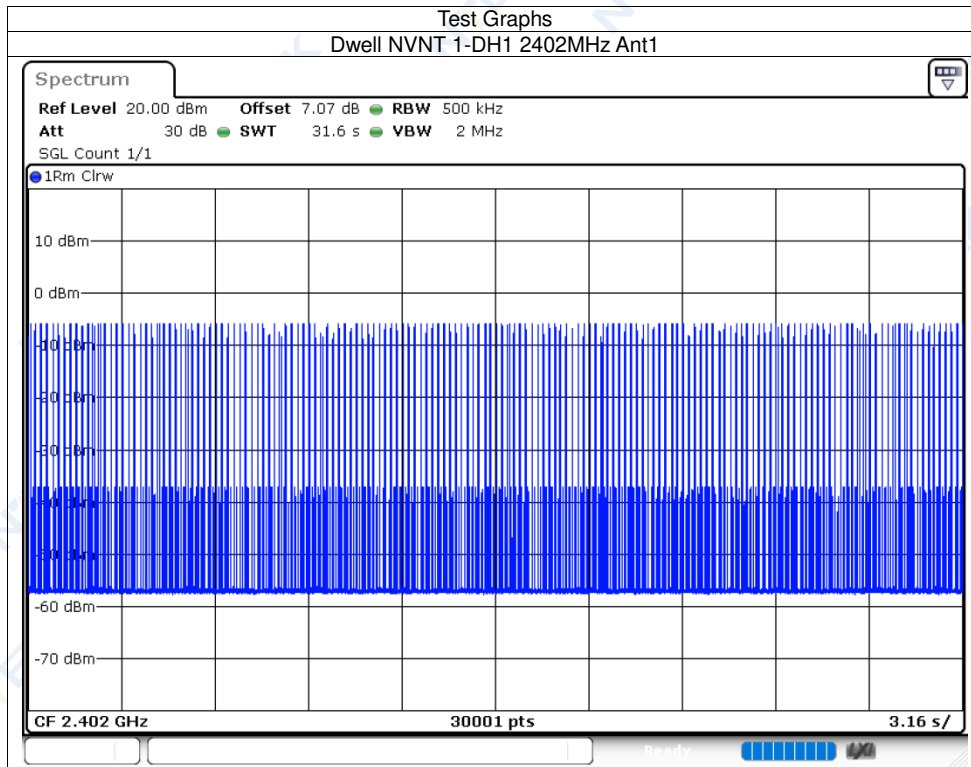

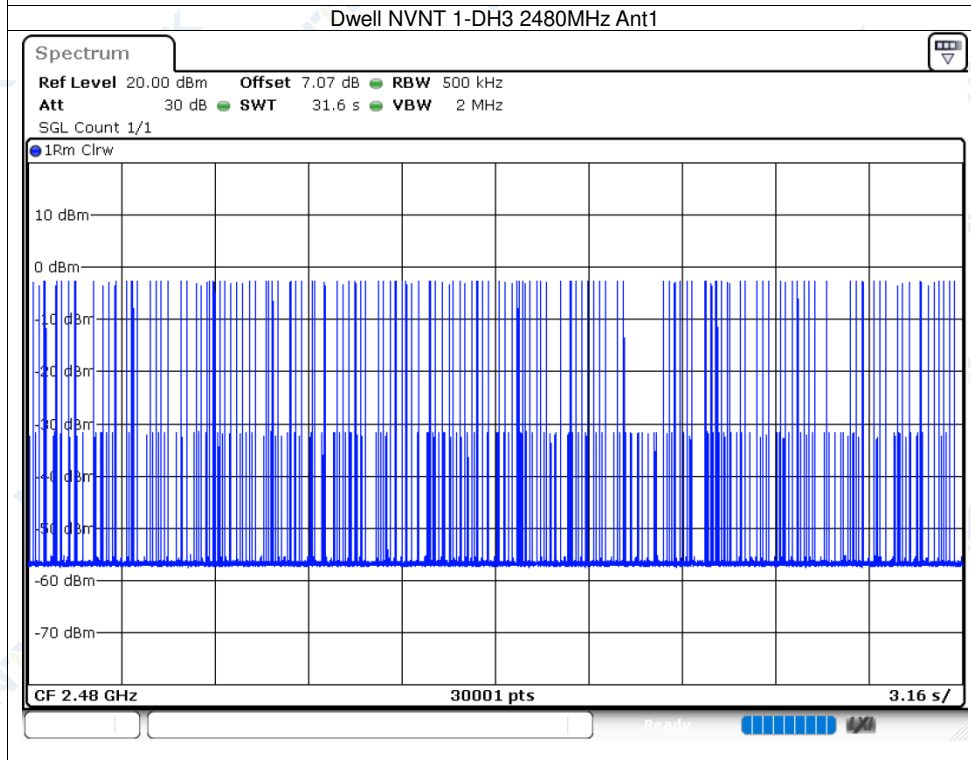
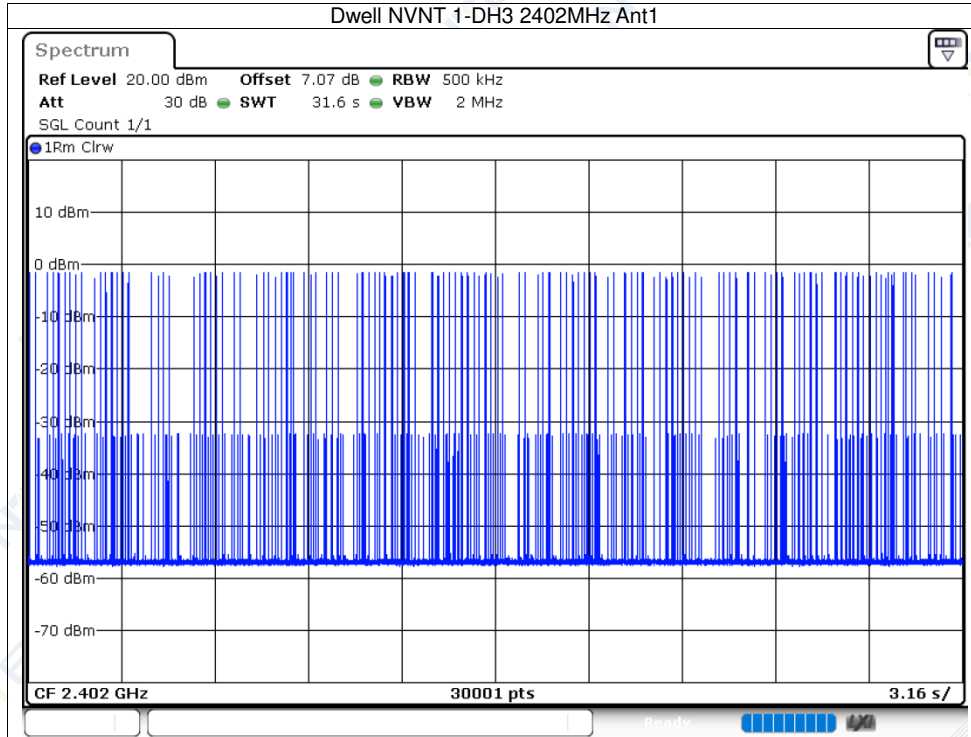

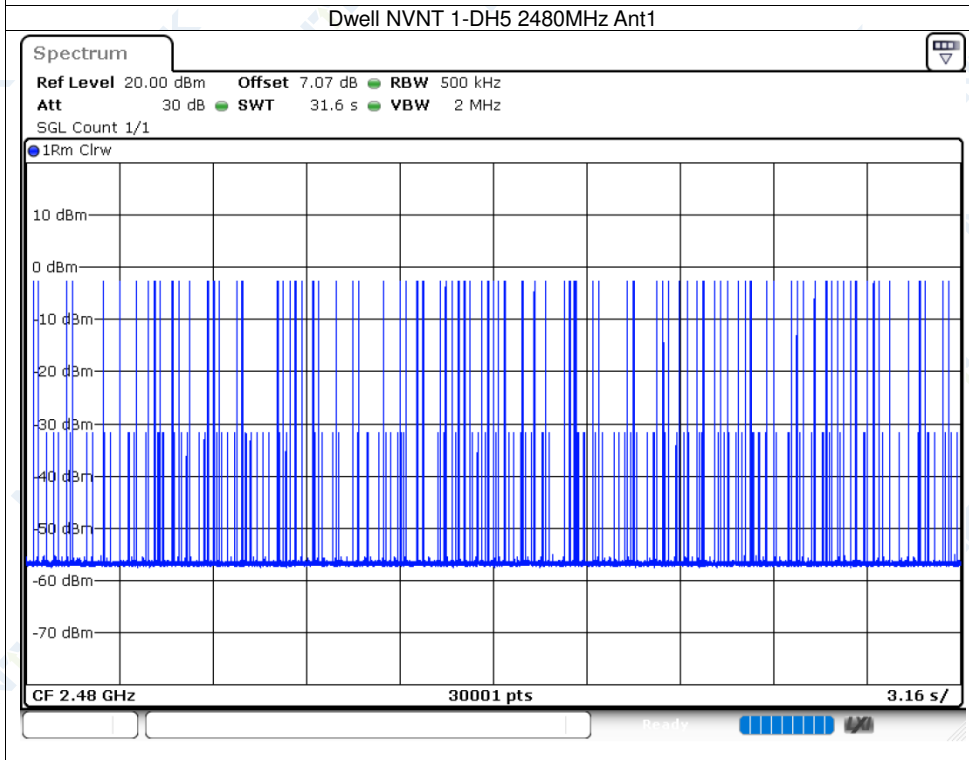
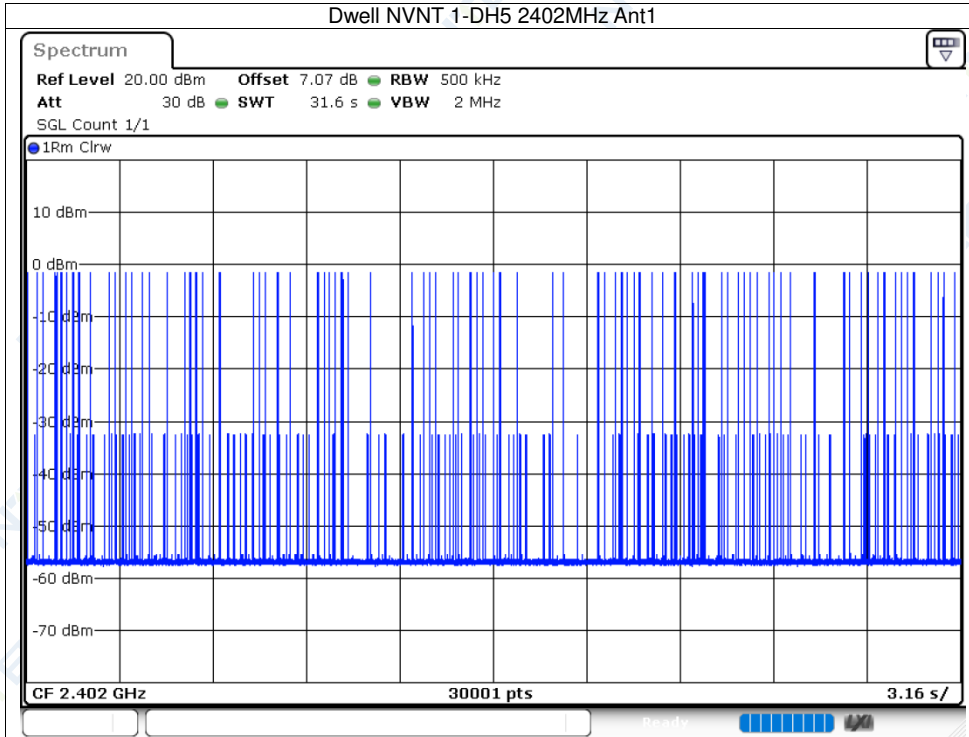

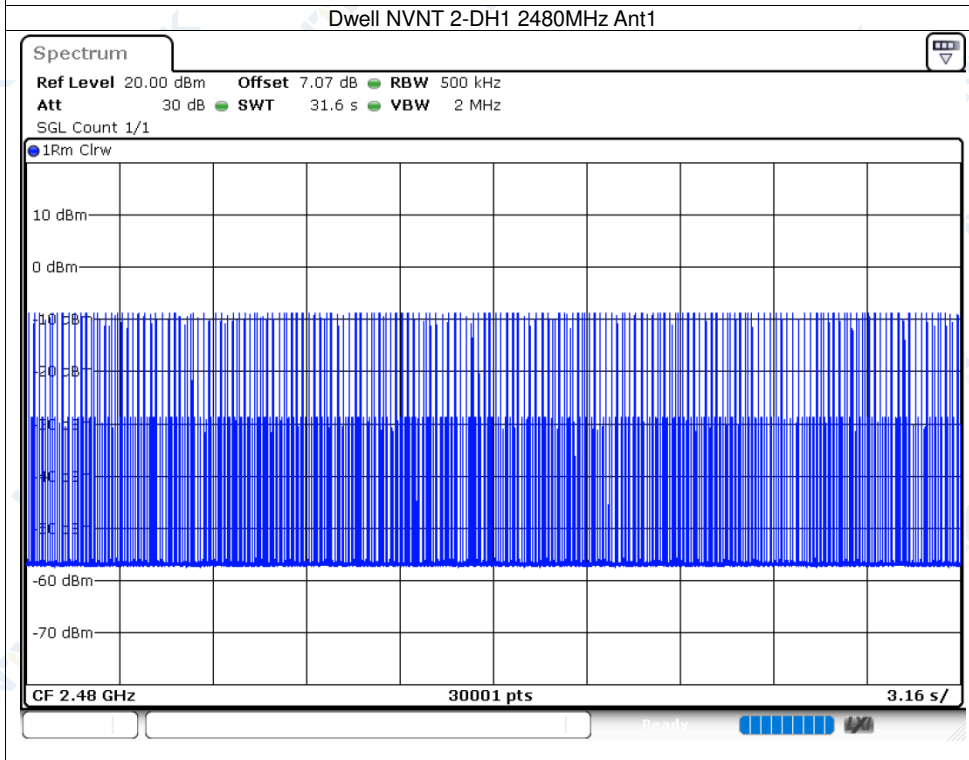
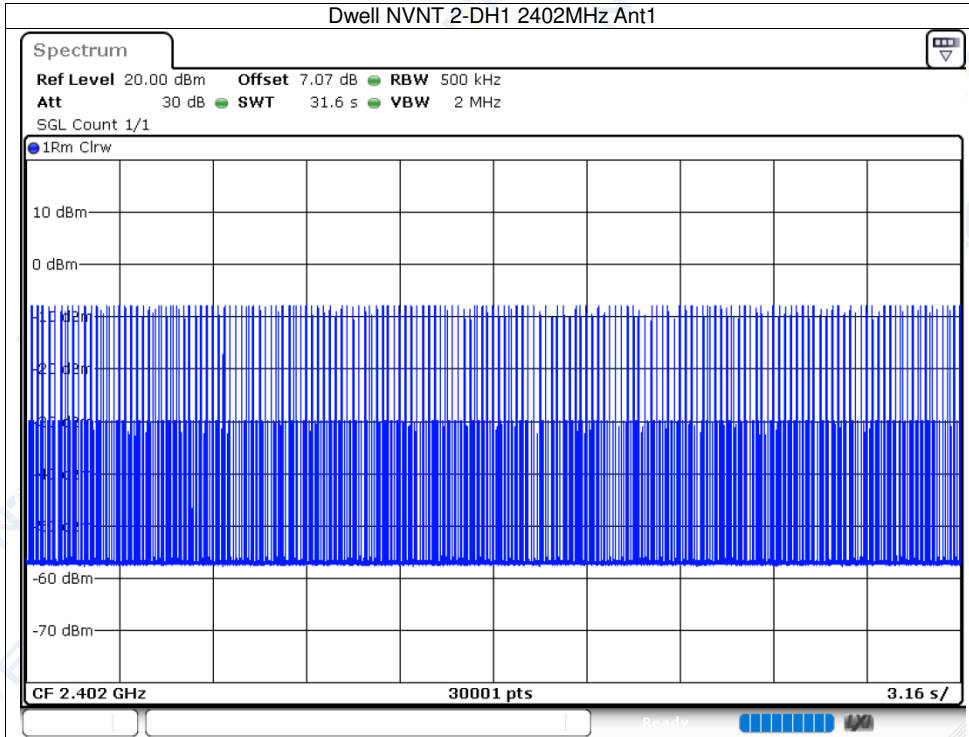

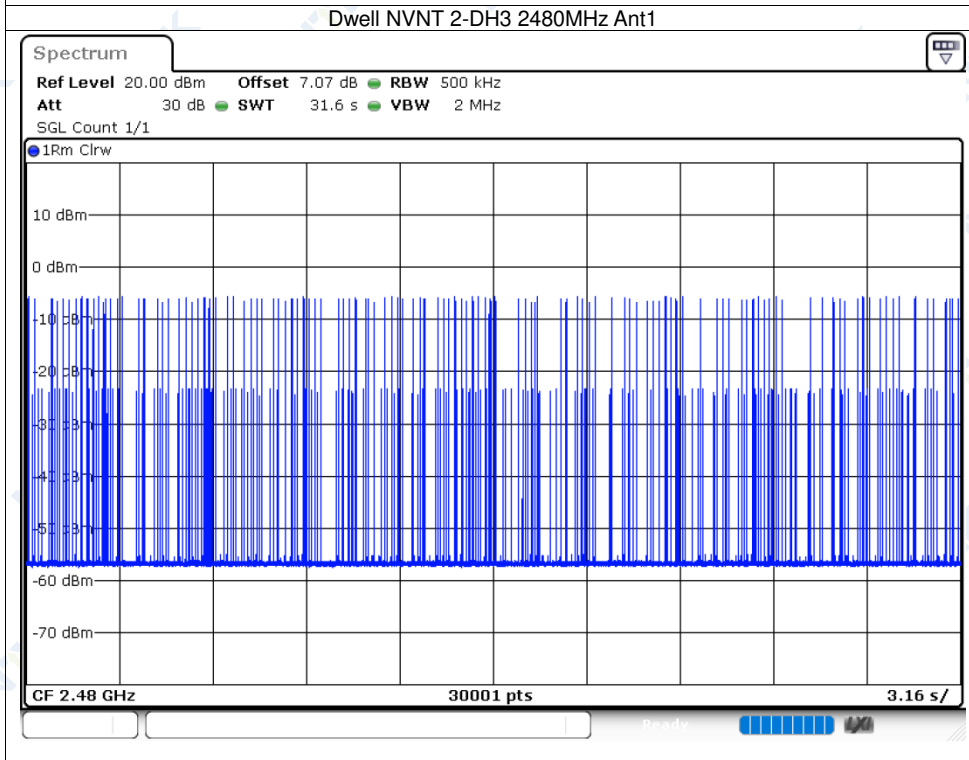
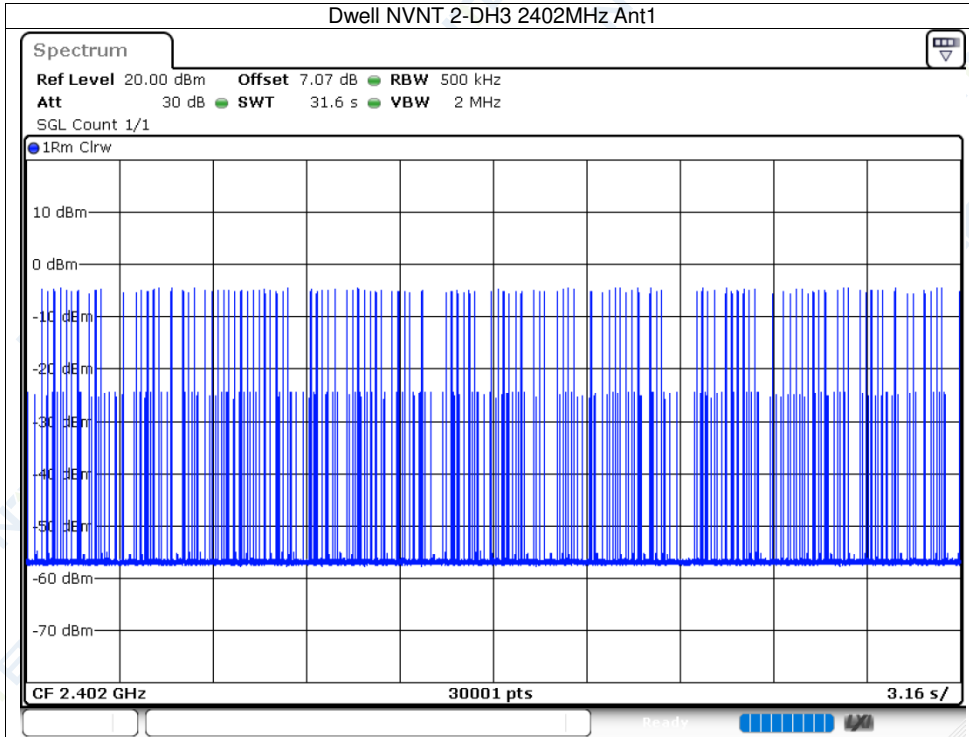

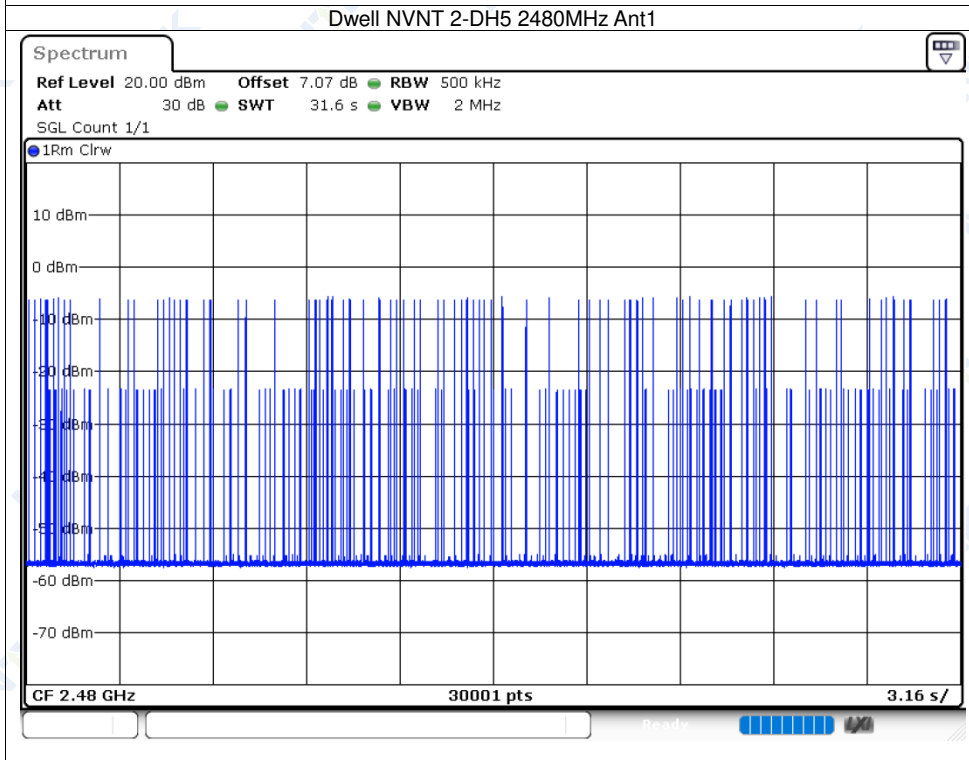
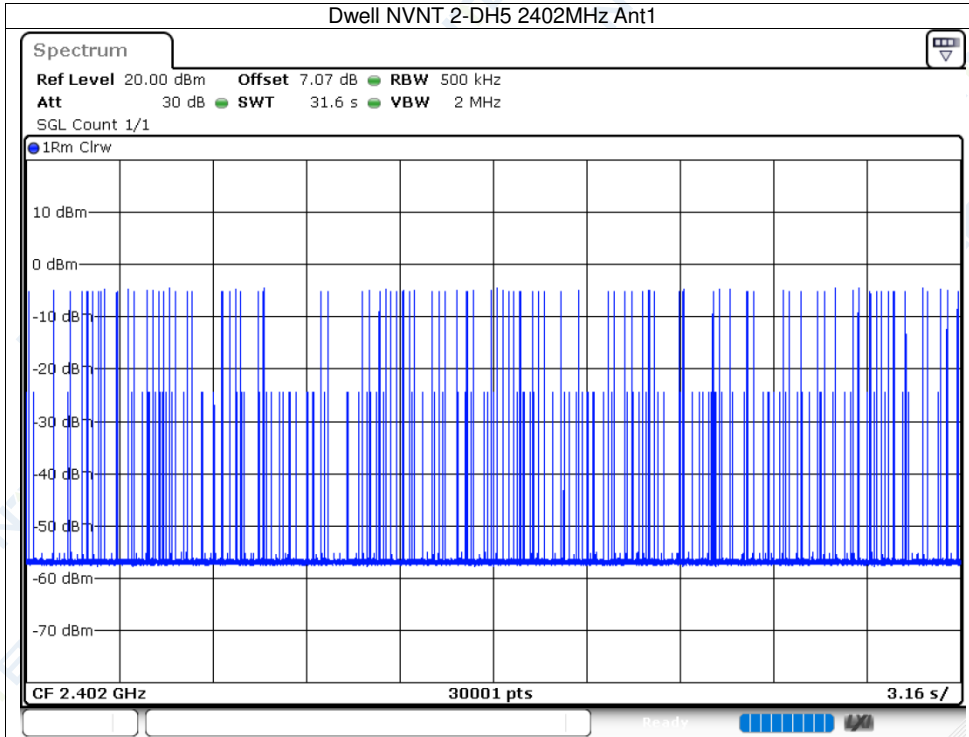

11.2 Frequency Occupation

Condition	Mode	Frequency (MHz)	Antenna	Burst Number	Limit	Sweep Time (ms)	Verdict
NVNT	1-DH1	2402	Ant1	1	1	121.028	Pass
NVNT	1-DH1	2480	Ant1	2	1	121.028	Pass
NVNT	1-DH3	2402	Ant1	2	1	518.24	Pass
NVNT	1-DH3	2480	Ant1	2	1	518.24	Pass
NVNT	1-DH5	2402	Ant1	2	1	913.24	Pass
NVNT	1-DH5	2480	Ant1	4	1	912.292	Pass
NVNT	2-DH1	2402	Ant1	1	1	123.872	Pass
NVNT	2-DH1	2480	Ant1	2	1	123.872	Pass
NVNT	2-DH3	2402	Ant1	1	1	517.608	Pass
NVNT	2-DH3	2480	Ant1	1	1	519.504	Pass
NVNT	2-DH5	2402	Ant1	4	1	913.872	Pass
NVNT	2-DH5	2480	Ant1	1	1	913.872	Pass

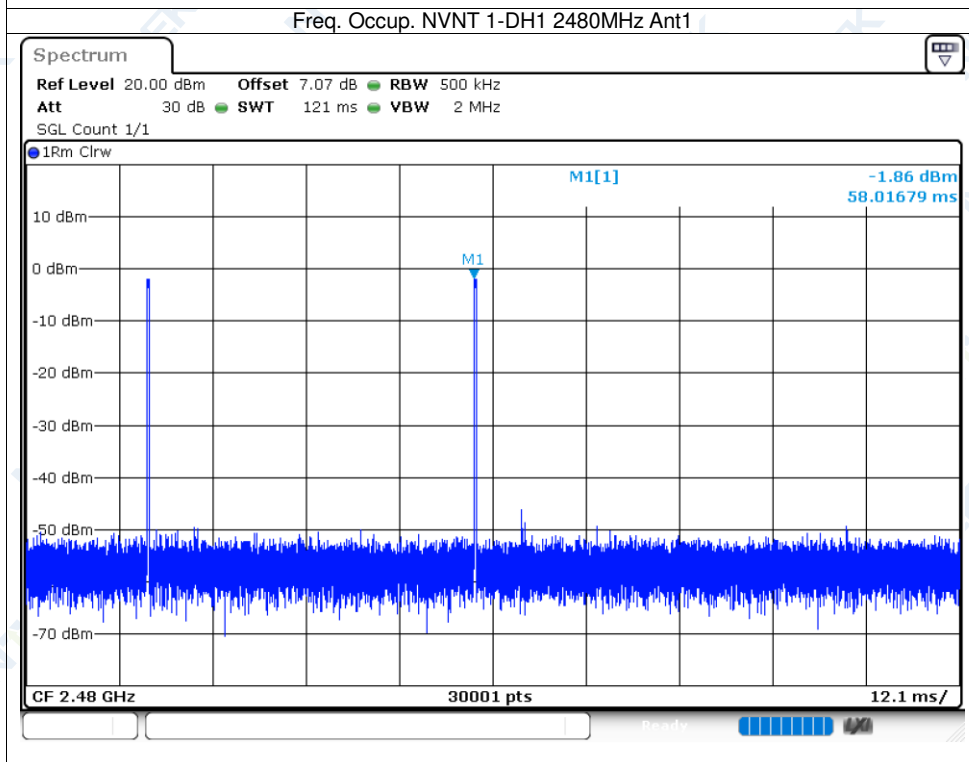
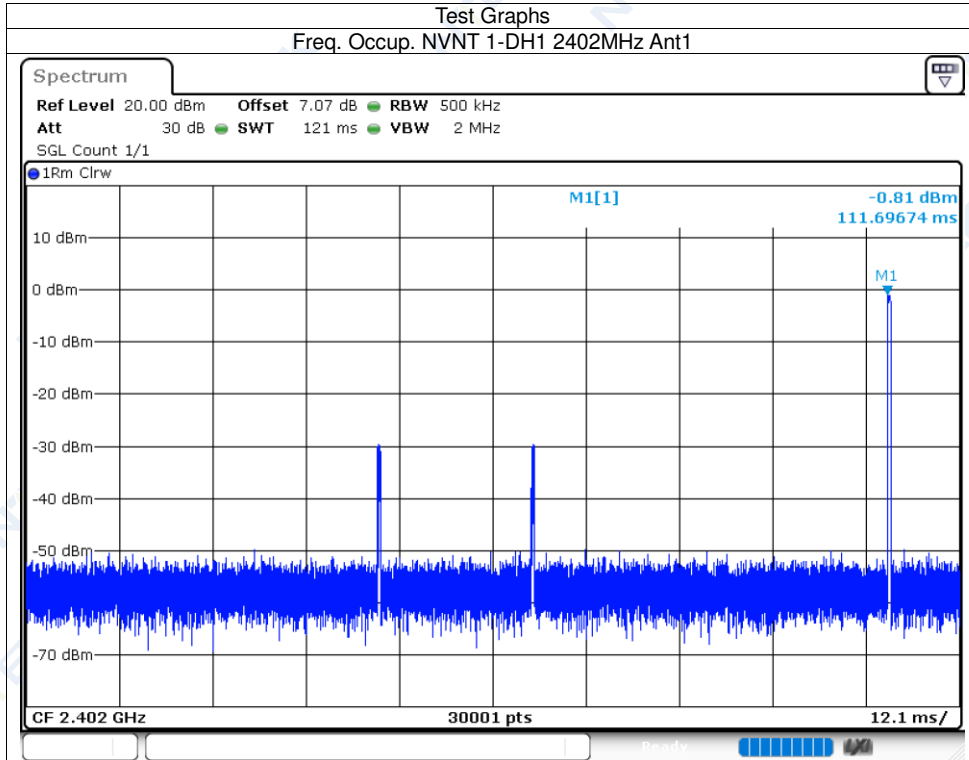

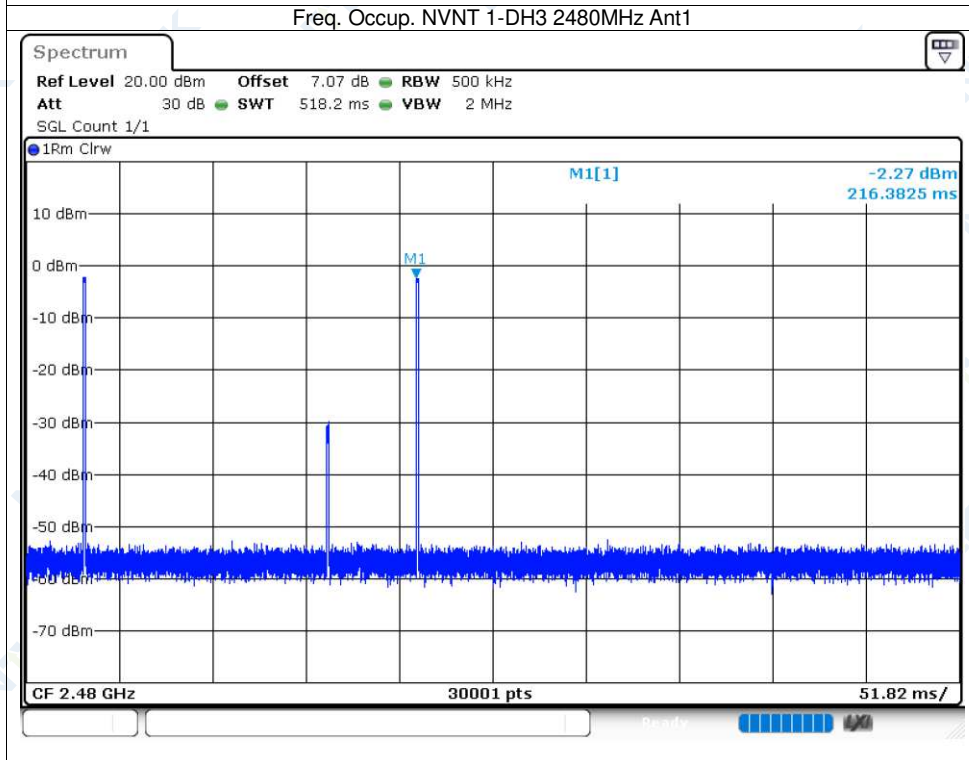
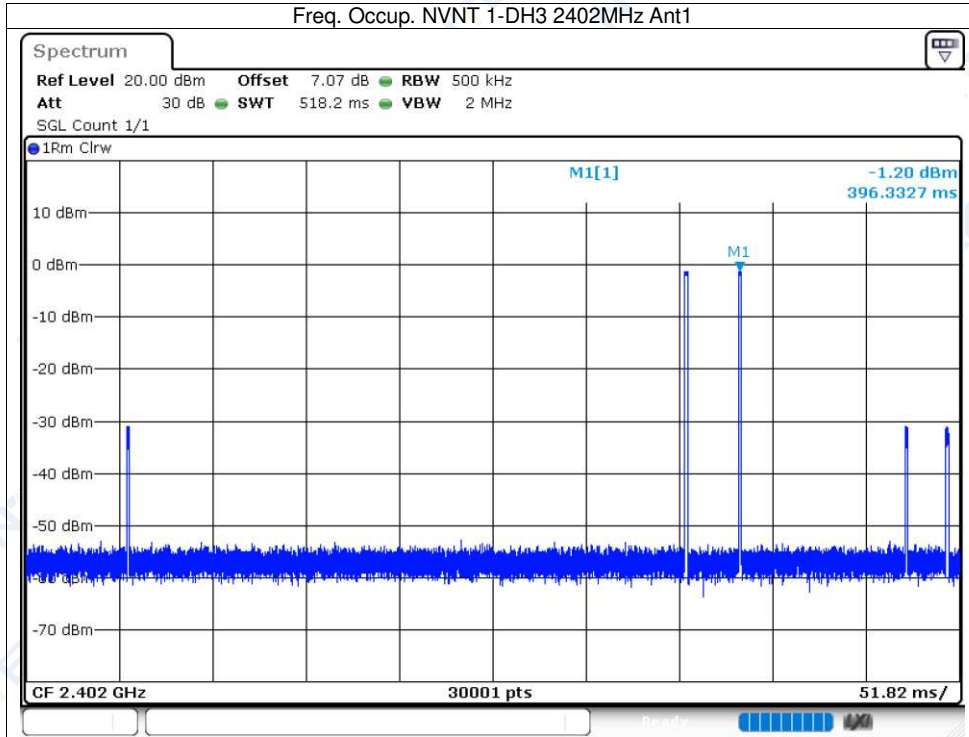

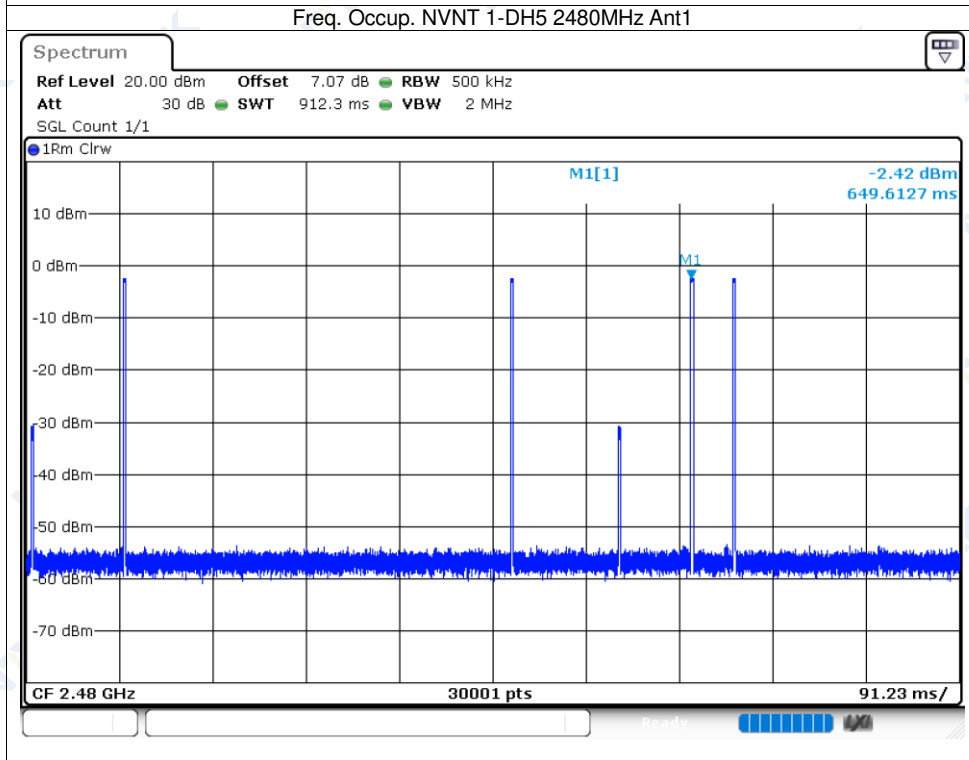
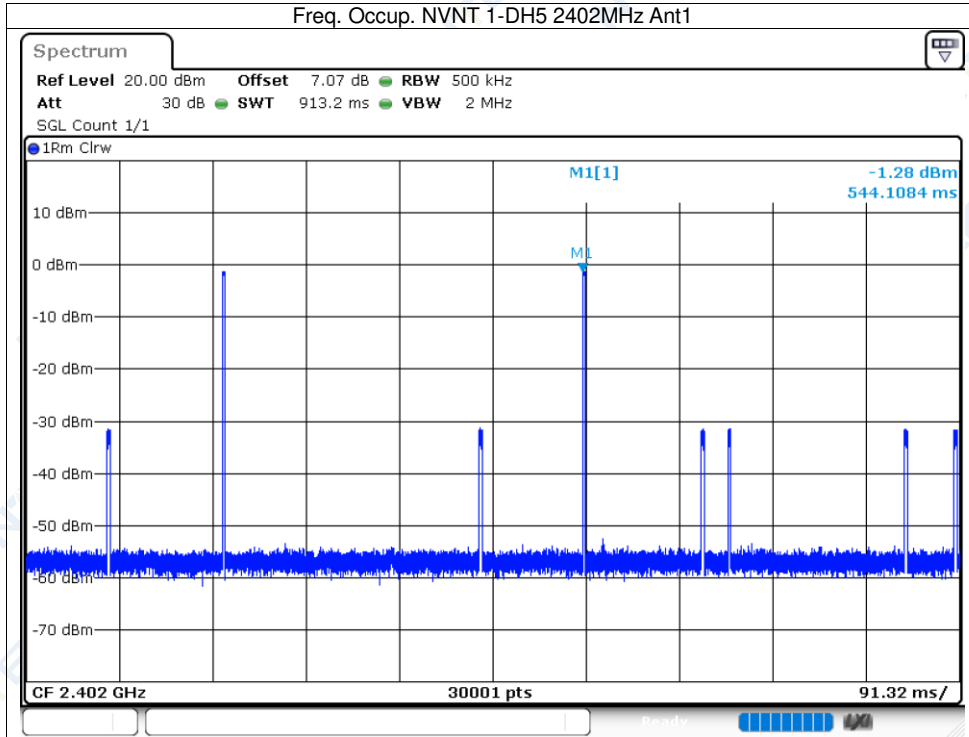

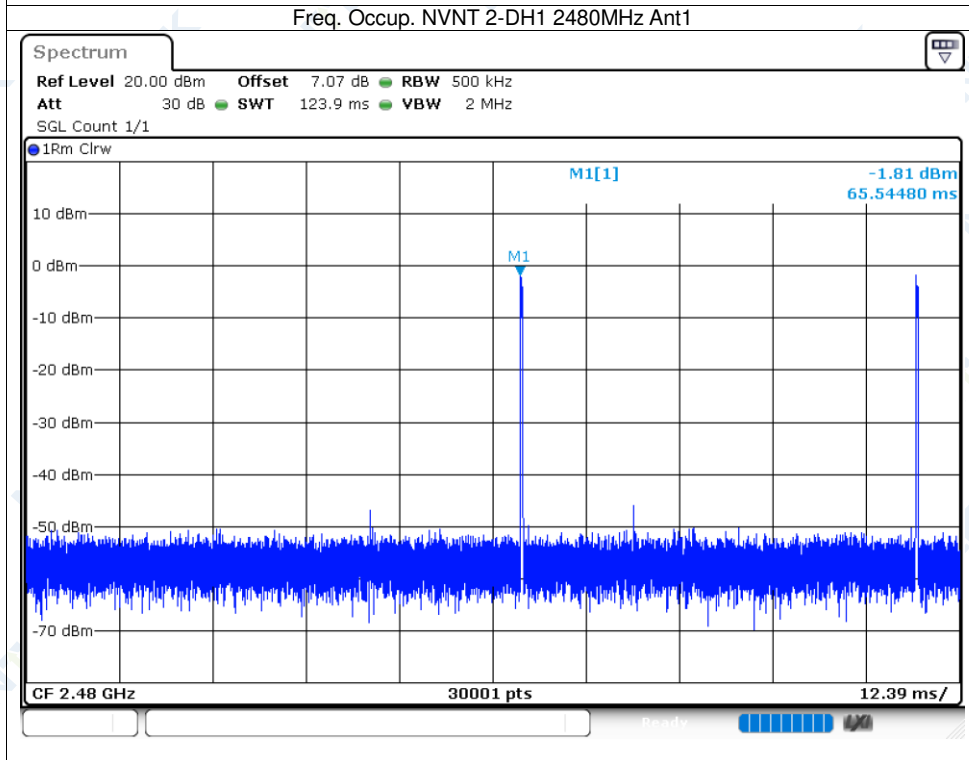
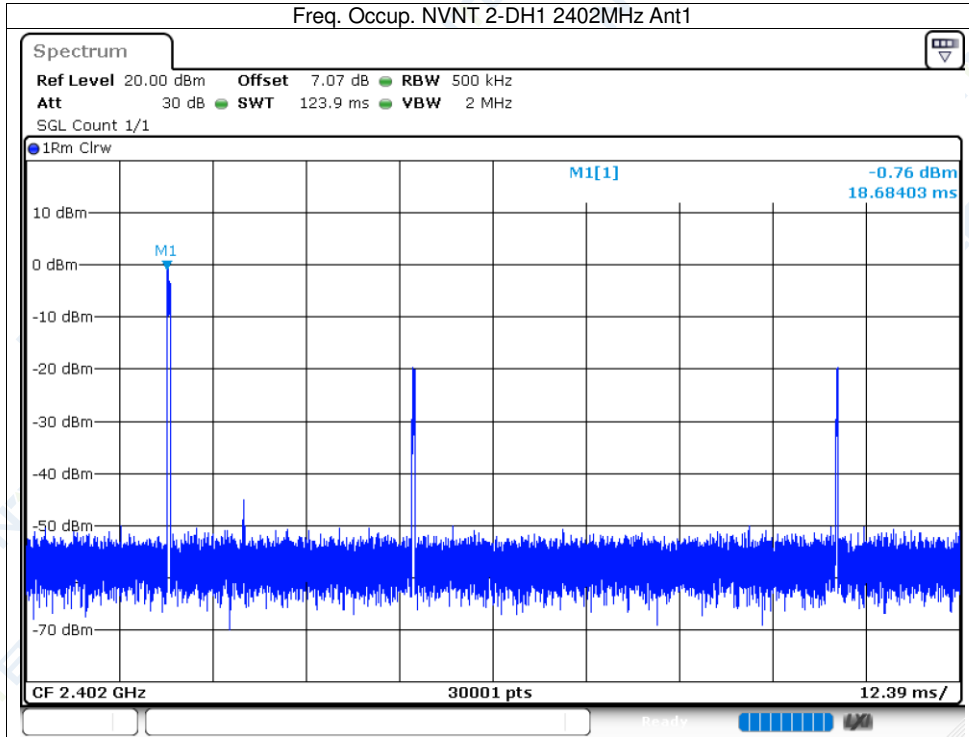

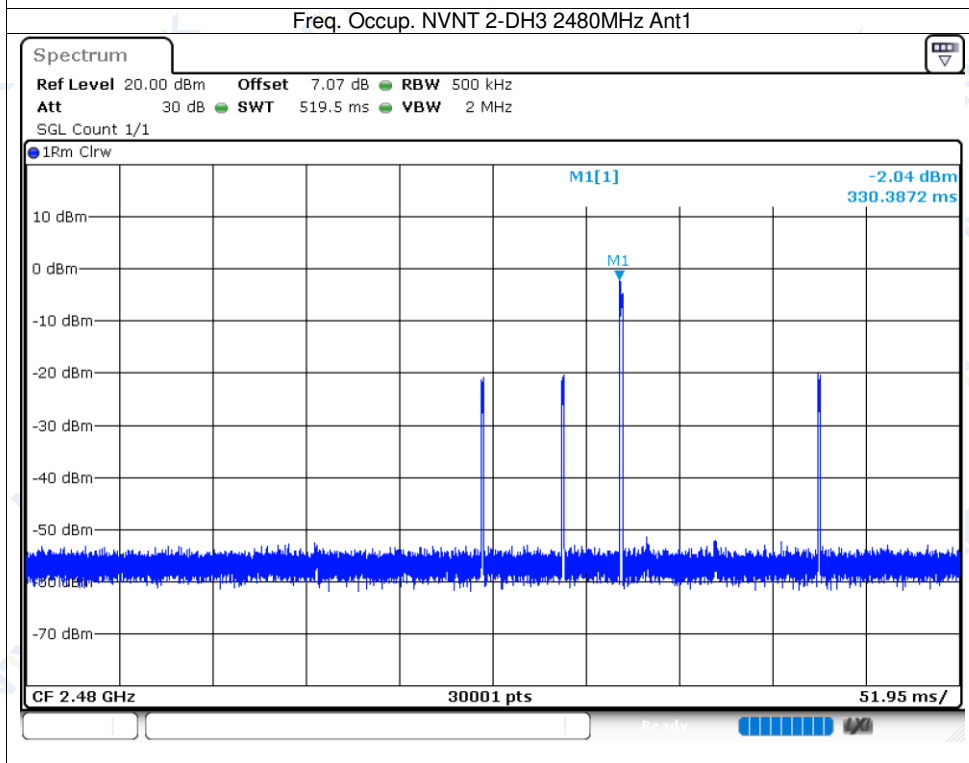
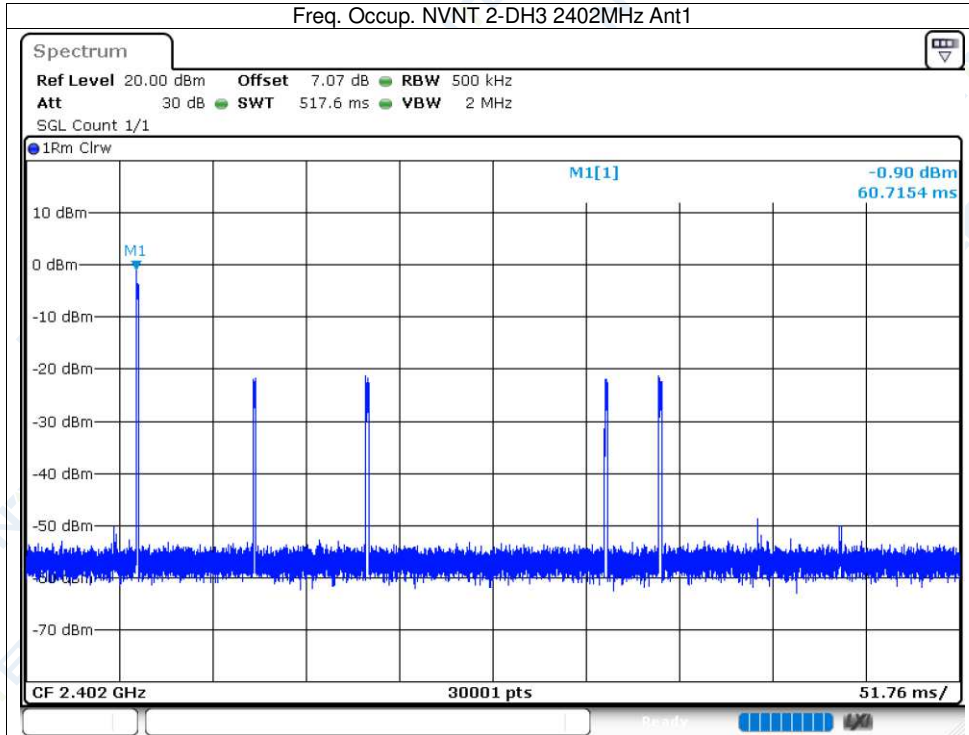

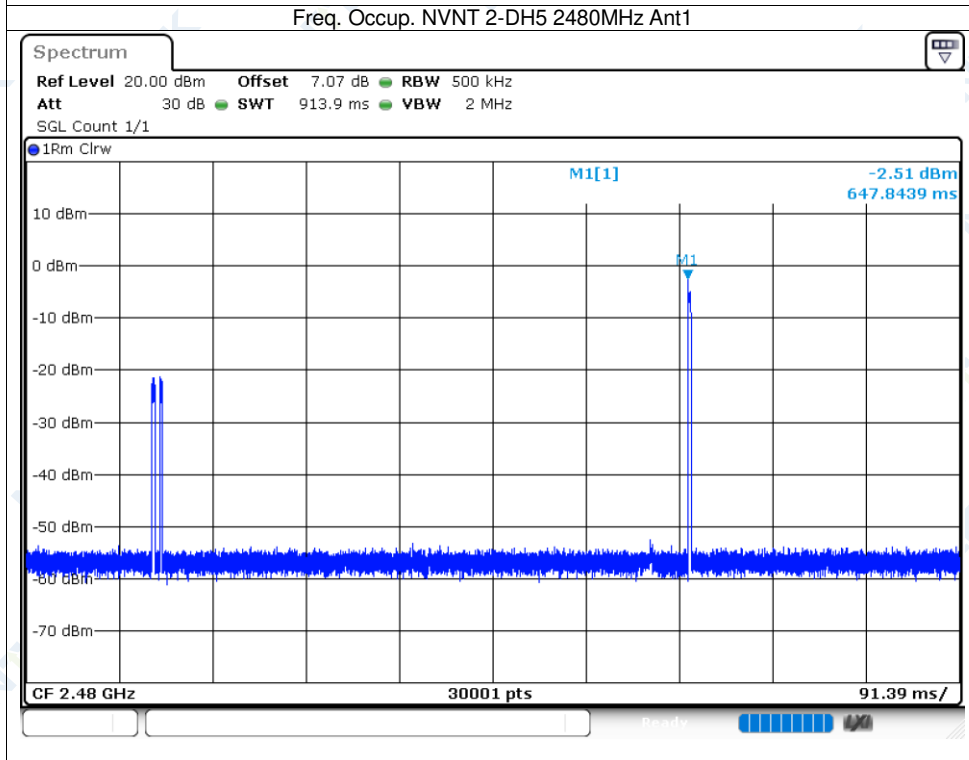
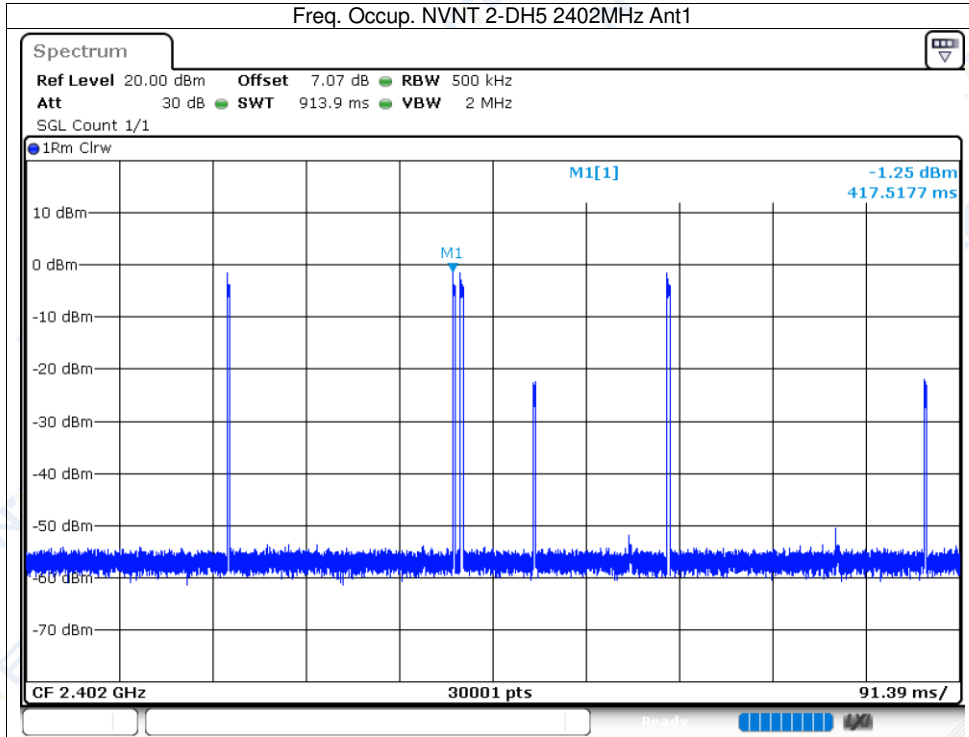

11.3 Dwell Time One Burst

Condition	Mode	Frequency (MHz)	Antenna	Pulse Time (ms)
NVNT	1-DH1	2402	Ant1	0.383
NVNT	1-DH1	2480	Ant1	0.383
NVNT	1-DH3	2402	Ant1	1.64
NVNT	1-DH3	2480	Ant1	1.64
NVNT	1-DH5	2402	Ant1	2.887
NVNT	1-DH5	2480	Ant1	2.887
NVNT	2-DH1	2402	Ant1	0.392
NVNT	2-DH1	2480	Ant1	0.392
NVNT	2-DH3	2402	Ant1	1.638
NVNT	2-DH3	2480	Ant1	1.644
NVNT	2-DH5	2402	Ant1	2.892
NVNT	2-DH5	2480	Ant1	2.892

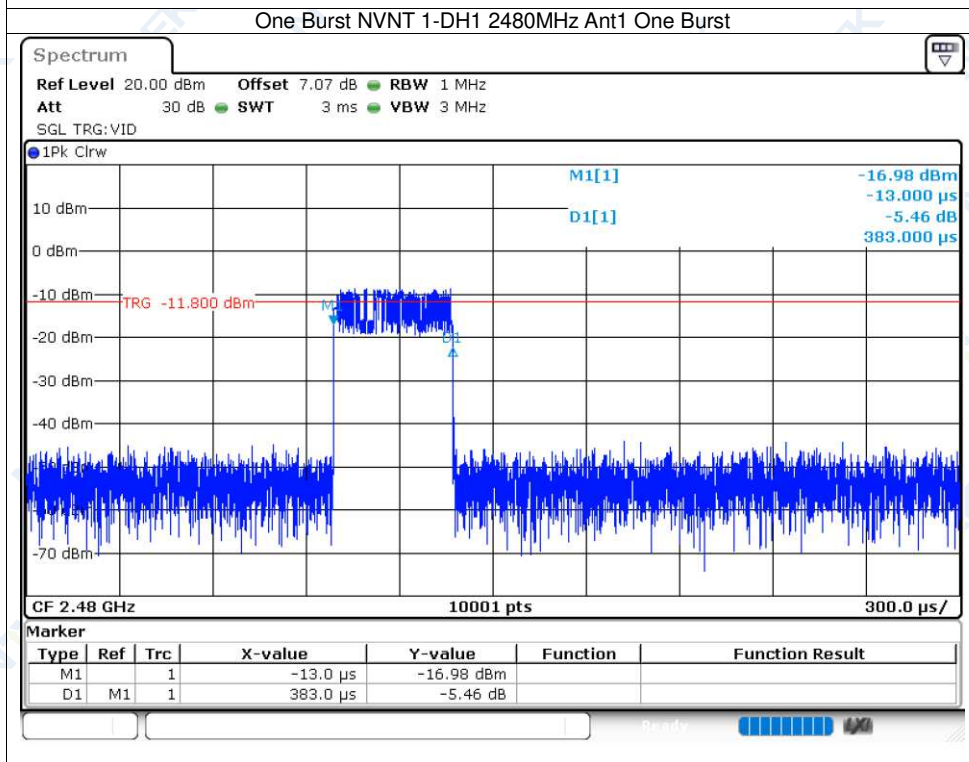
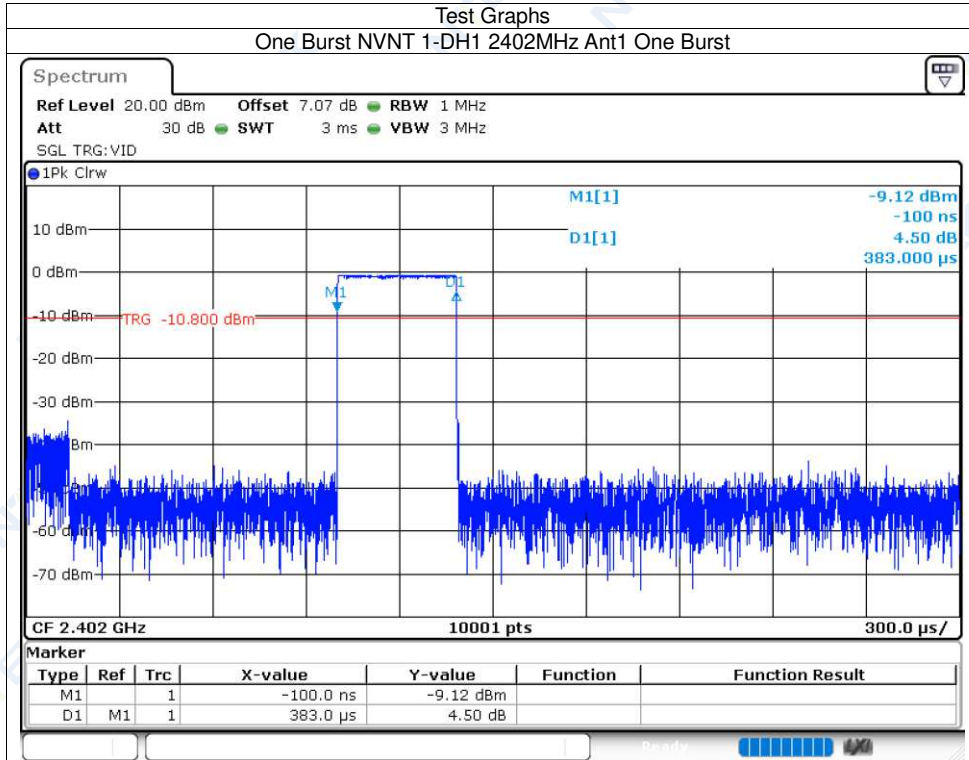

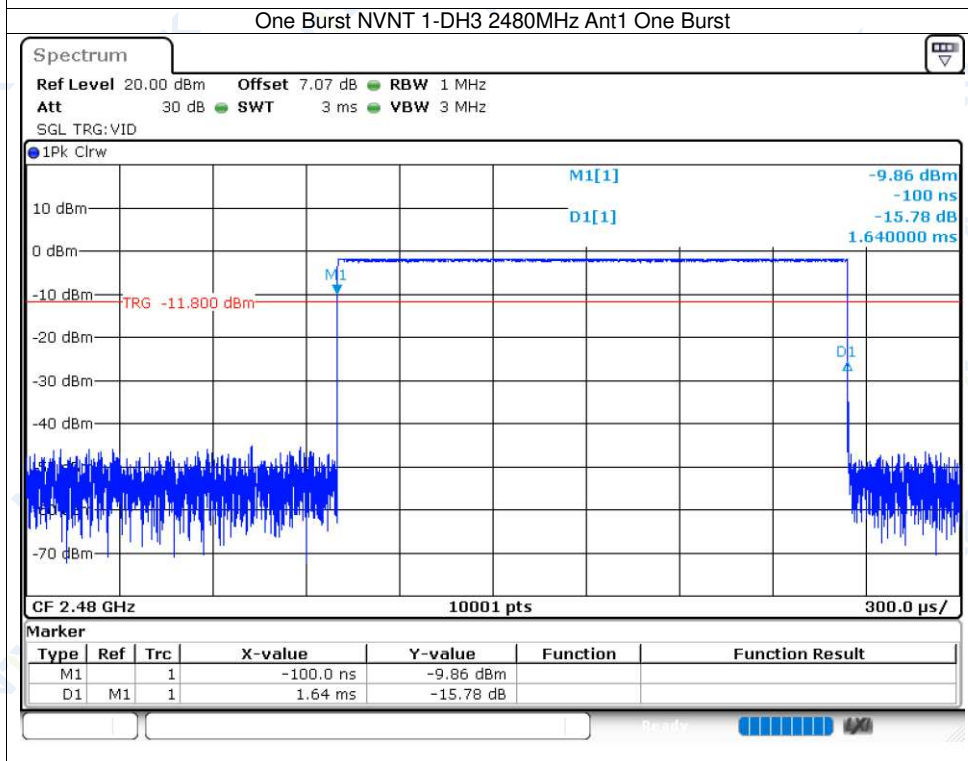
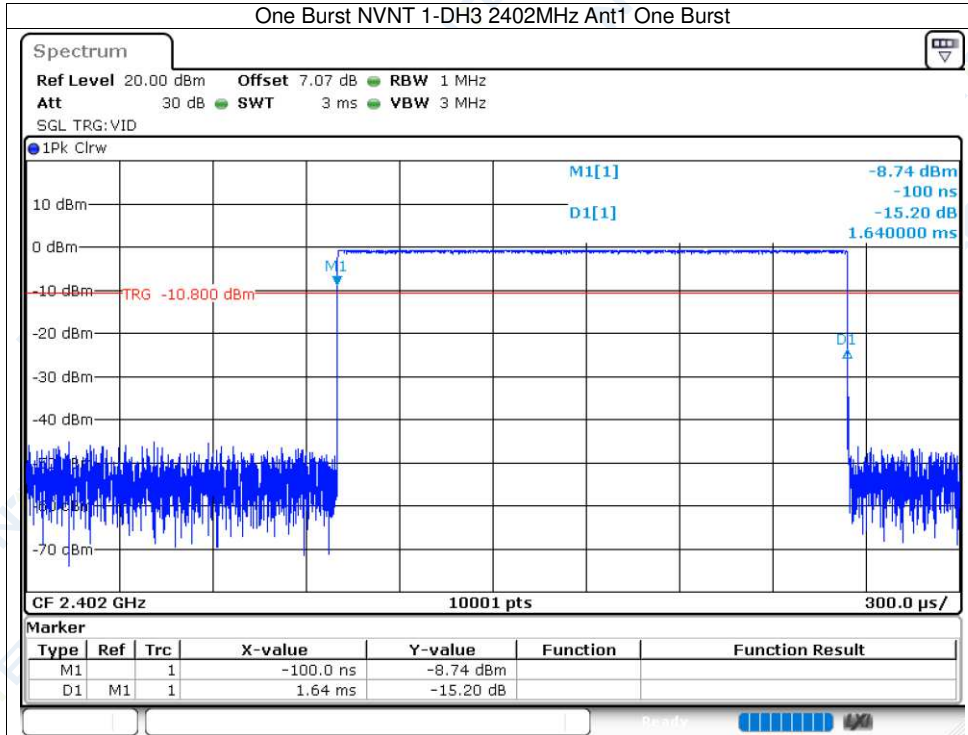

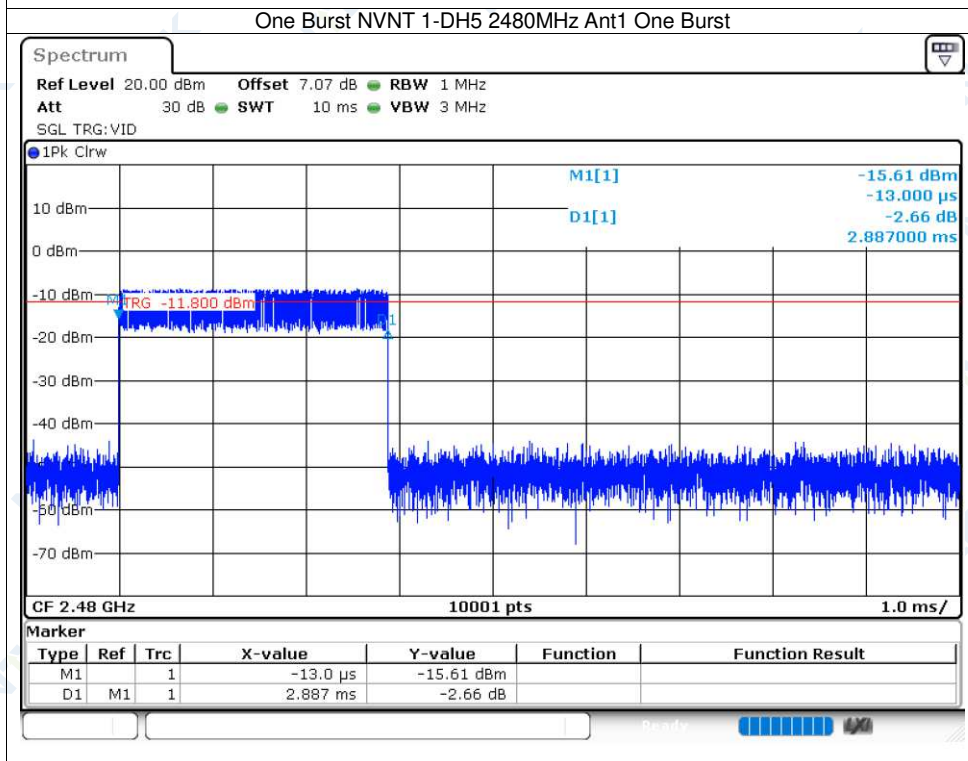
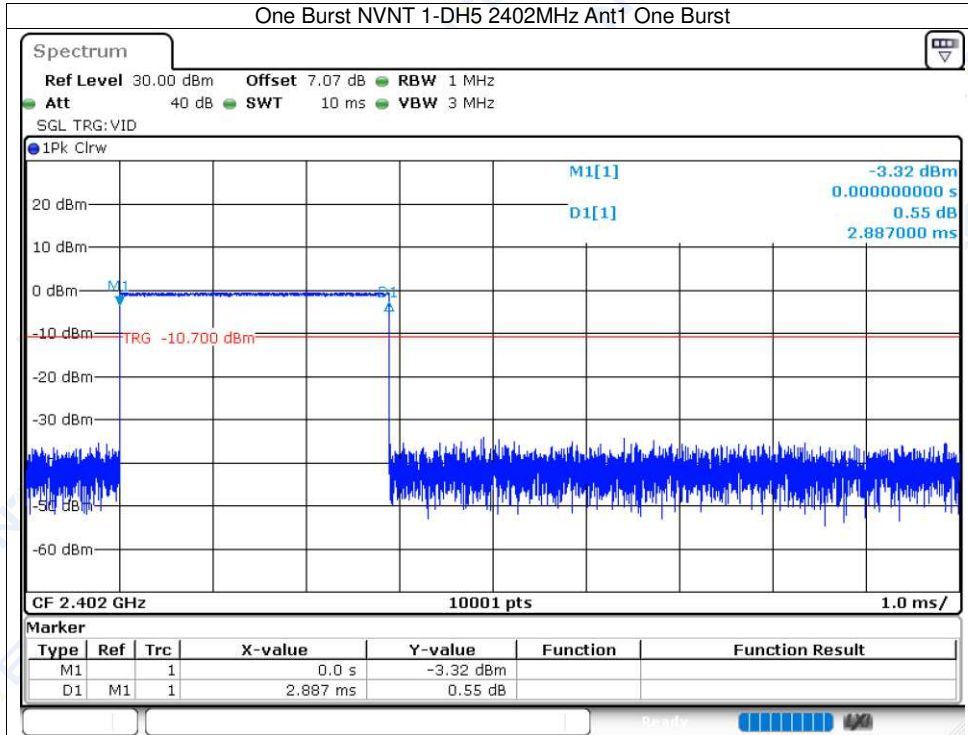

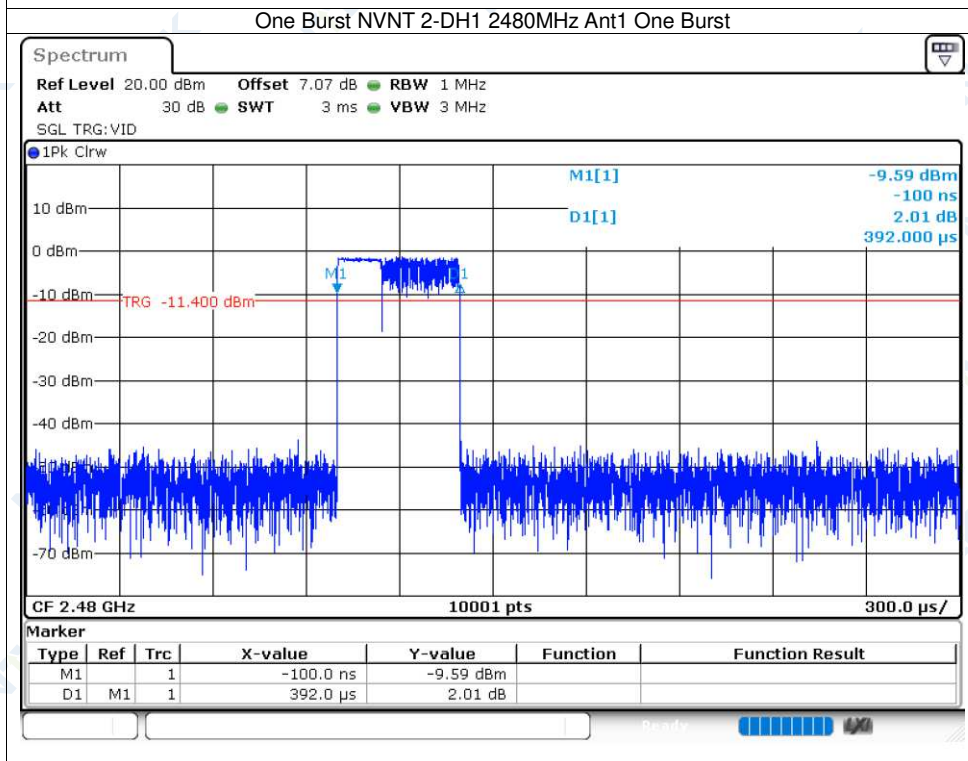
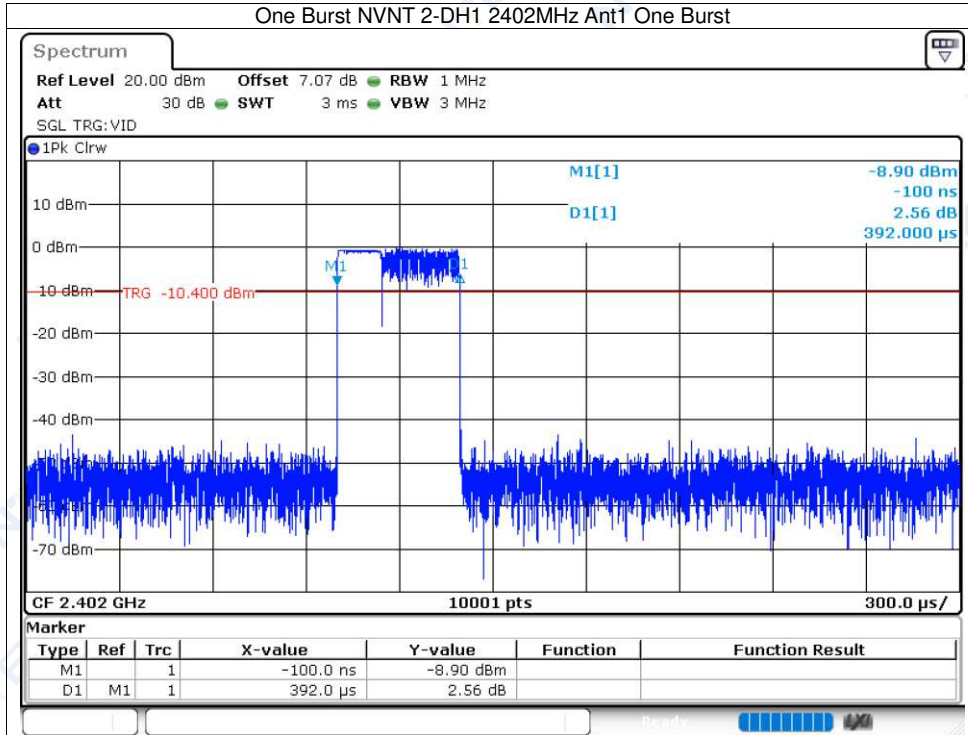

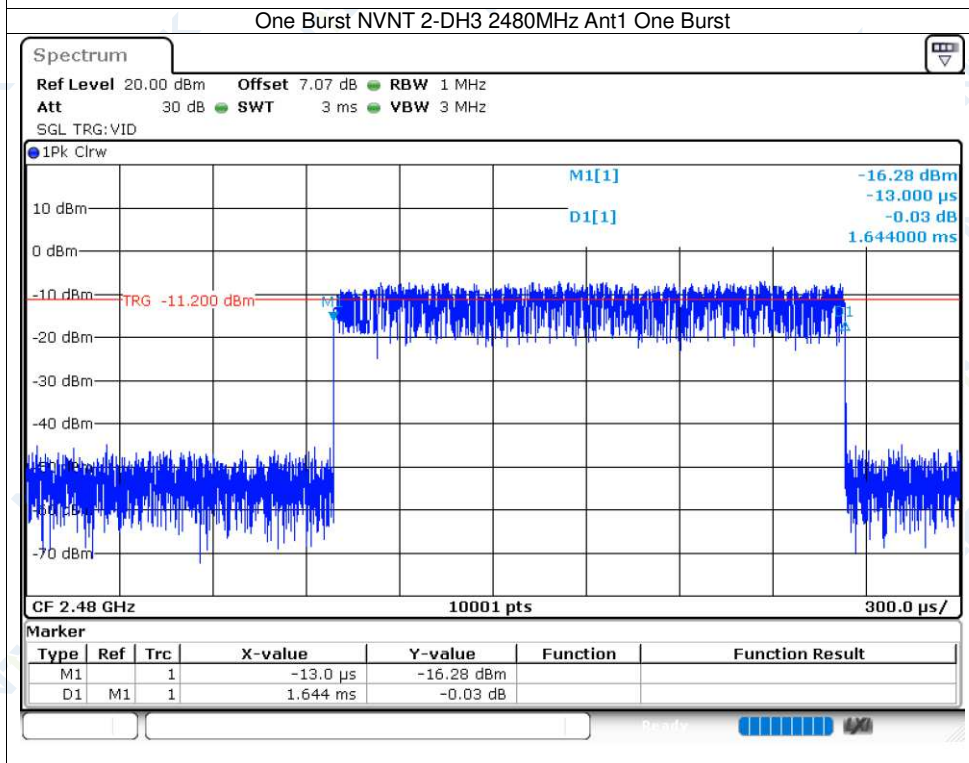
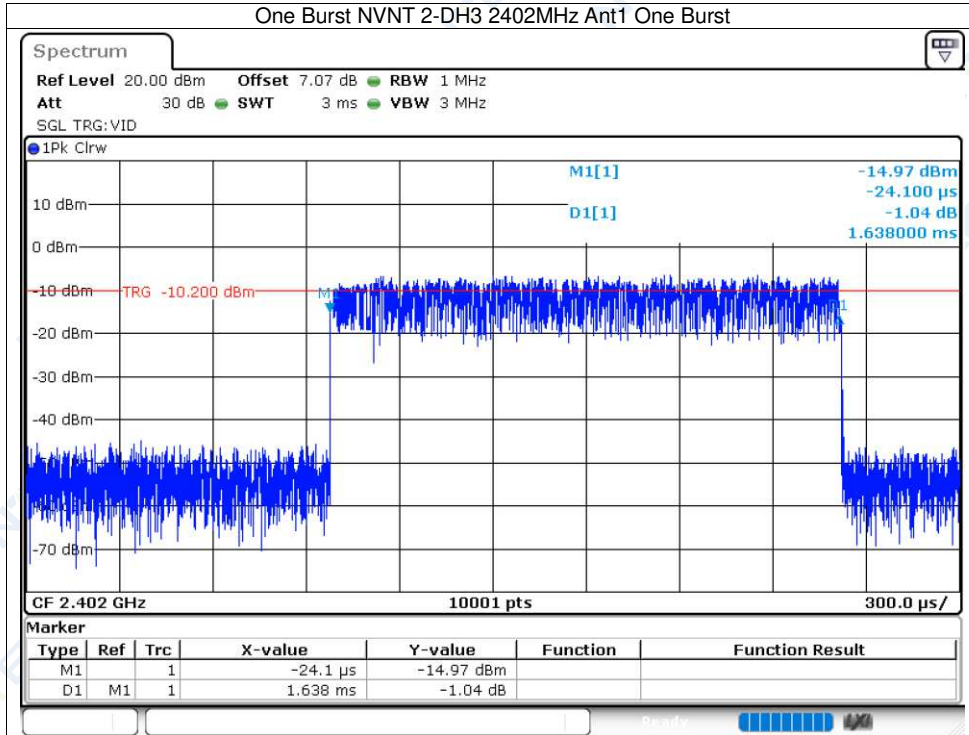

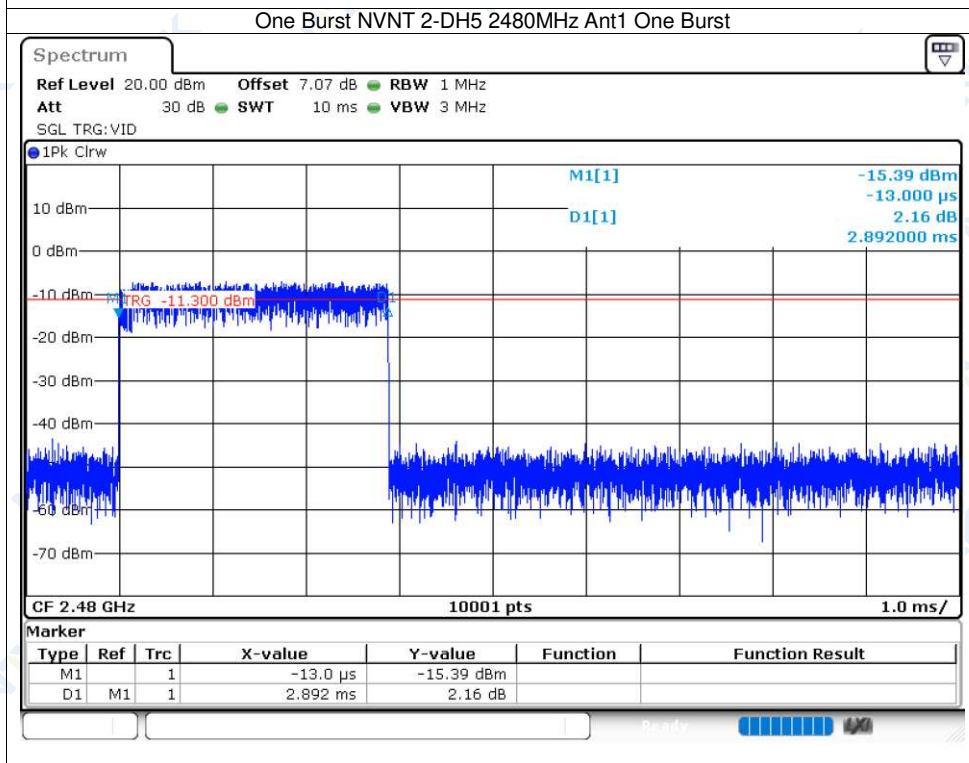
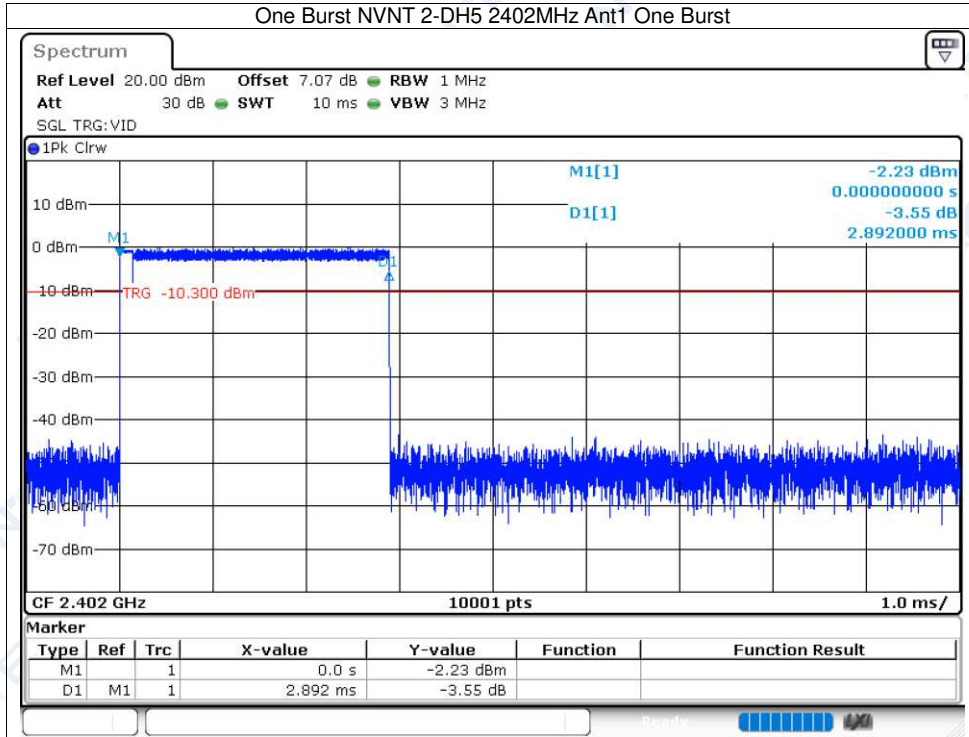

11.4 RF Output Power

Condition	Mode	Frequency (MHz)	Antenna	Max Burst RMS Power (dBm)	Burst Number	Max EIRP (dBm)	Limit (dBm)	Verdict
NVNT	1-DH5	hopping	Ant1	-1.52	27	0.23	20	Pass
NVNT	2-DH5	hopping	Ant1	-1.87	37	-0.12	20	Pass
NVLT	1-DH5	hopping	Ant1	-2.30	27	-0.55	20	Pass
NVLT	2-DH5	hopping	Ant1	-2.48	37	-0.73	20	Pass
NVHT	1-DH5	hopping	Ant1	-2.28	27	-0.53	20	Pass
NVHT	2-DH5	hopping	Ant1	-2.52	37	-0.77	20	Pass

Test Graphs
Power NVNT 1-DH5 2402MHz Ant1

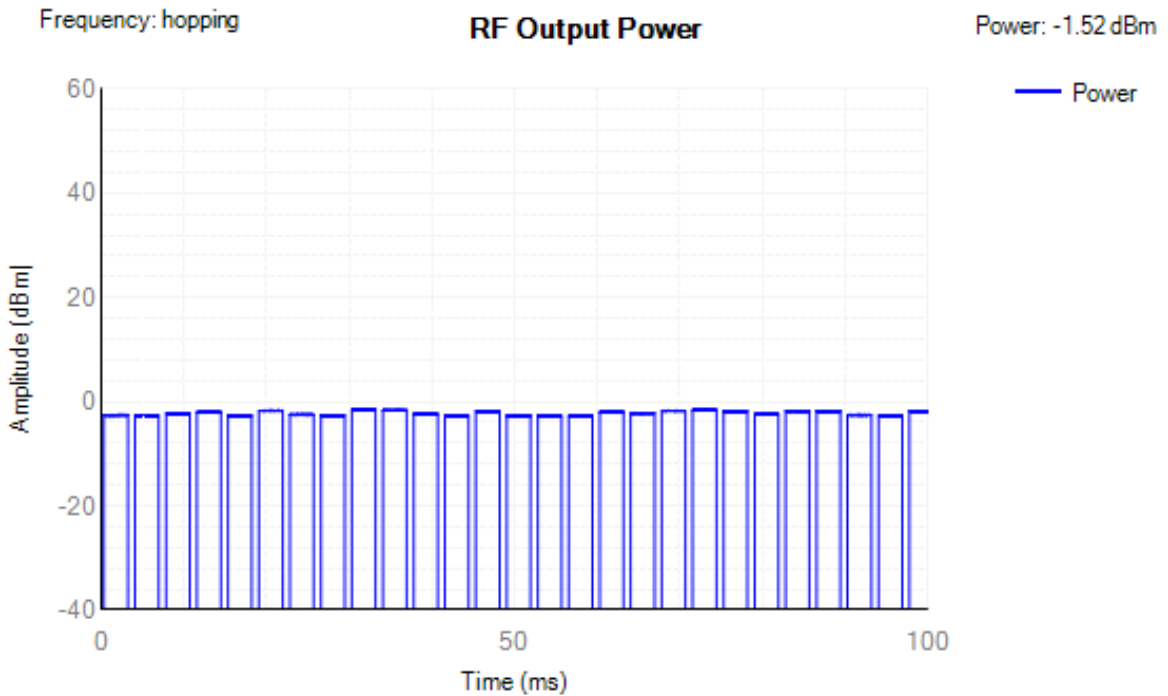

Power NVNT 2-DH5 2402MHz Ant1

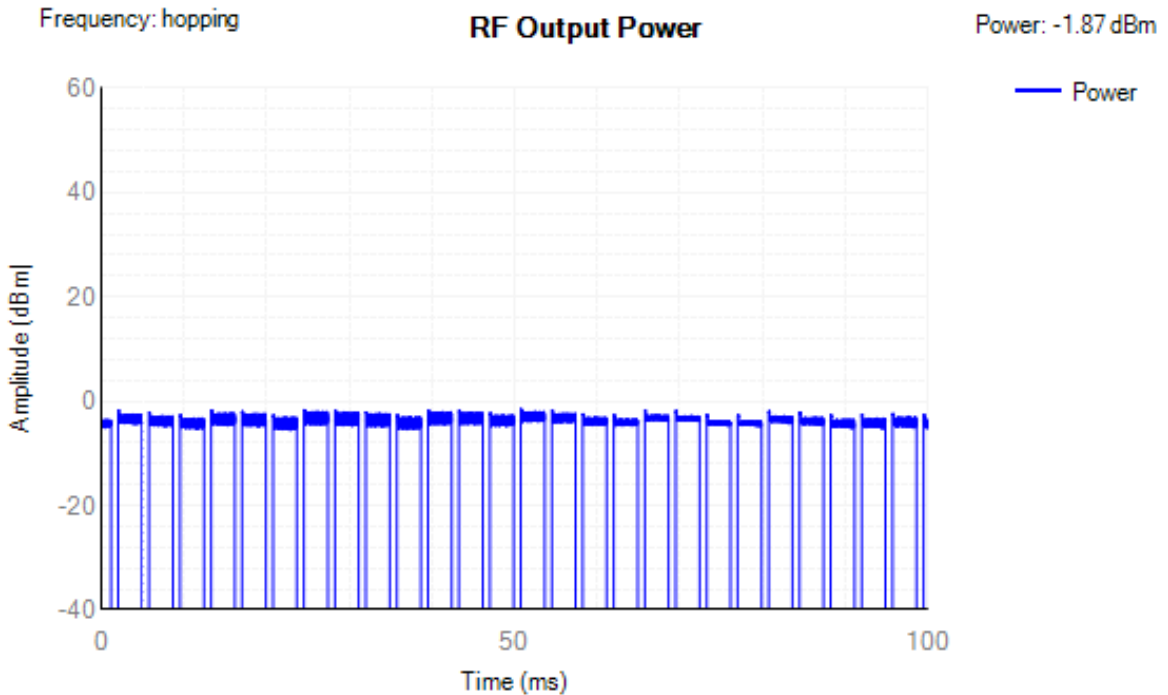

11.5 Hopping Frequency Separation

Condition	Mode	Antenna	Hopping Freq1 (MHz)	Hopping Freq2 (MHz)	HFS (MHz)	Limit (MHz)	Verdict
NVNT	1-DH5	Ant1	2402.033	2403.034	1.001	0.1	Pass
NVNT	1-DH5	Ant1	2441.031	2442.037	1.006	0.1	Pass
NVNT	1-DH5	Ant1	2479.033	2480.038	1.005	0.1	Pass
NVNT	2-DH5	Ant1	2402.018	2403.02	1.002	0.1	Pass
NVNT	2-DH5	Ant1	2441.018	2442.02	1.002	0.1	Pass
NVNT	2-DH5	Ant1	2479.018	2480.02	1.002	0.1	Pass

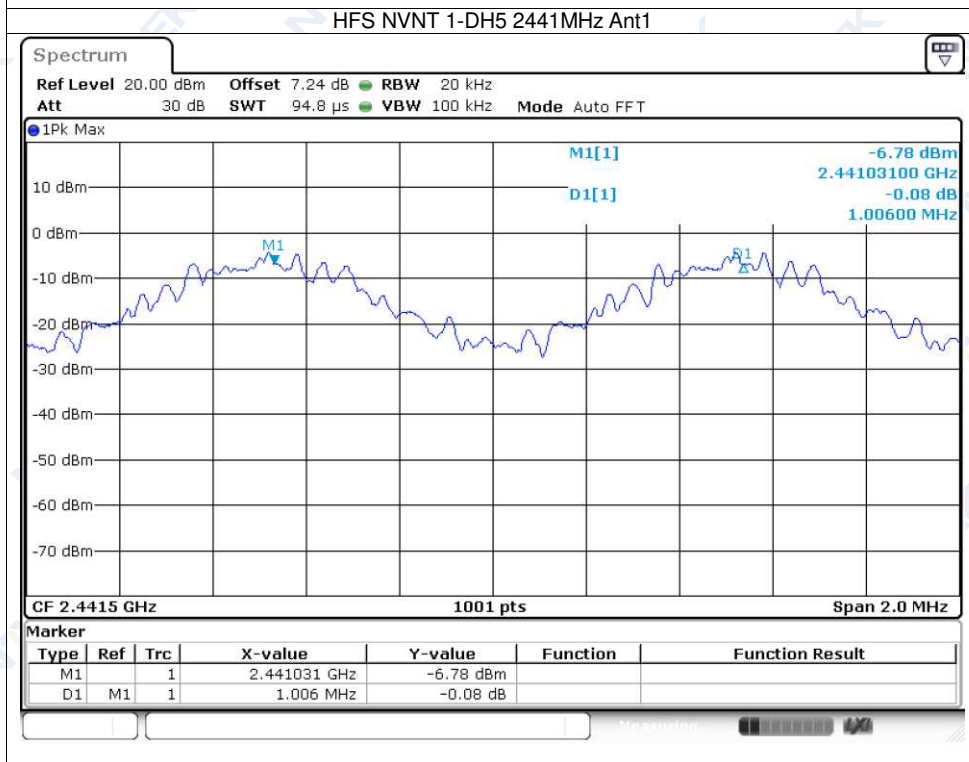
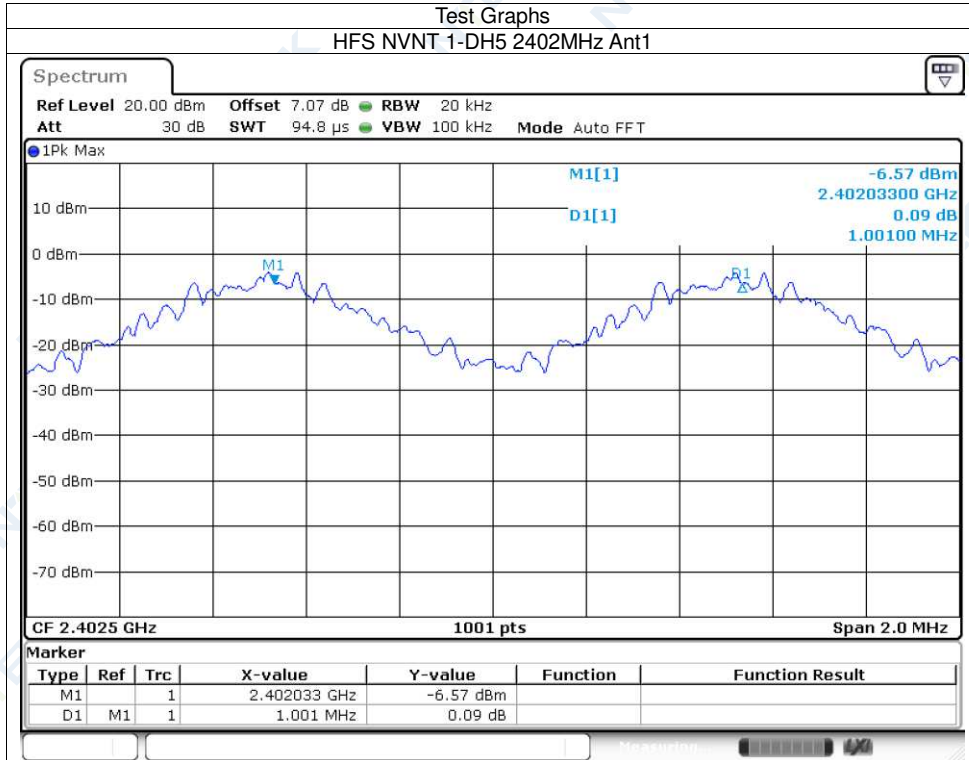

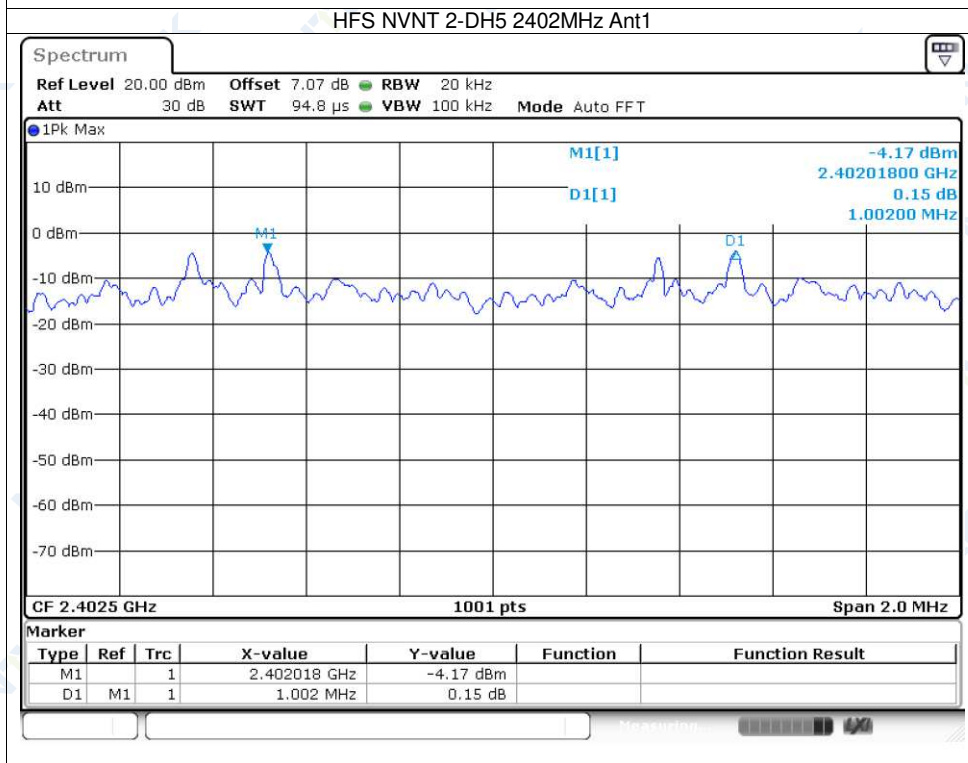
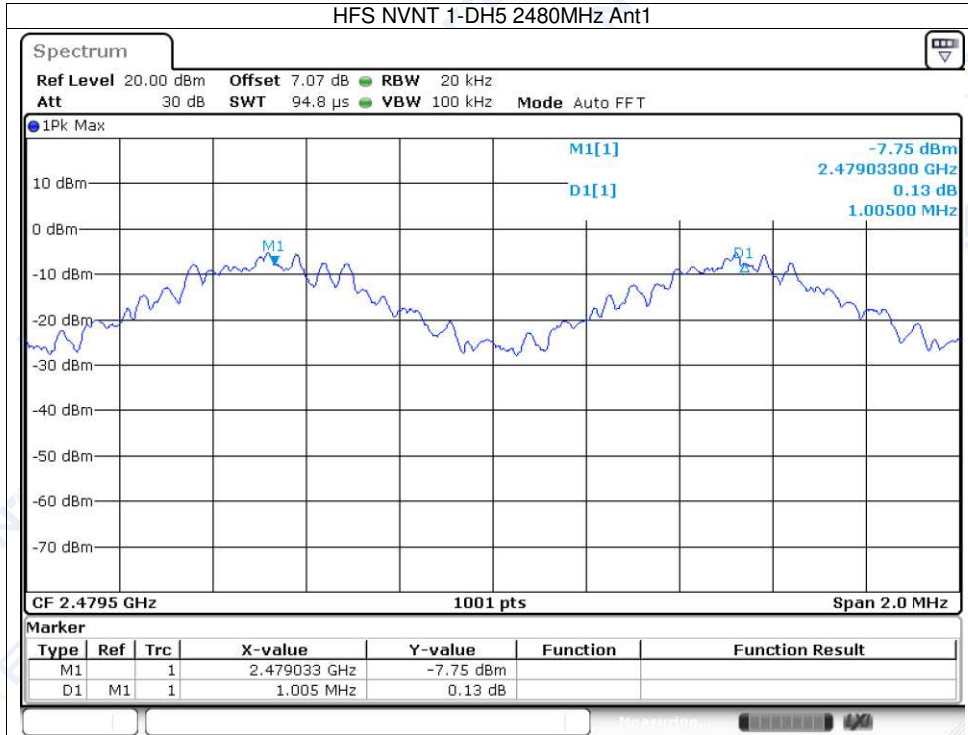

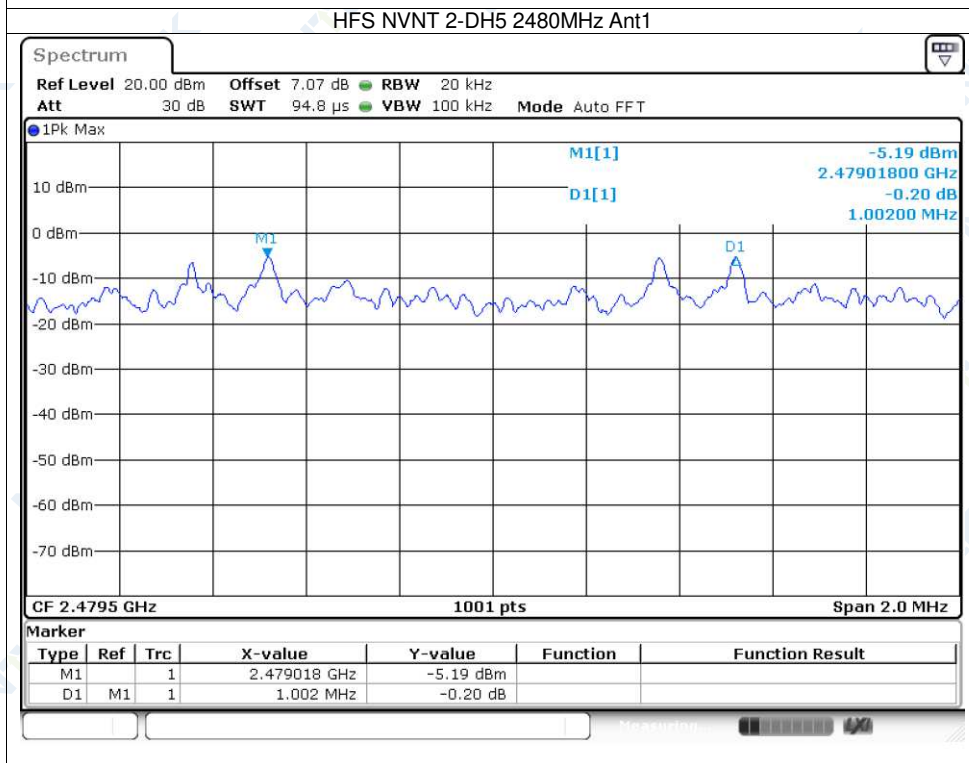
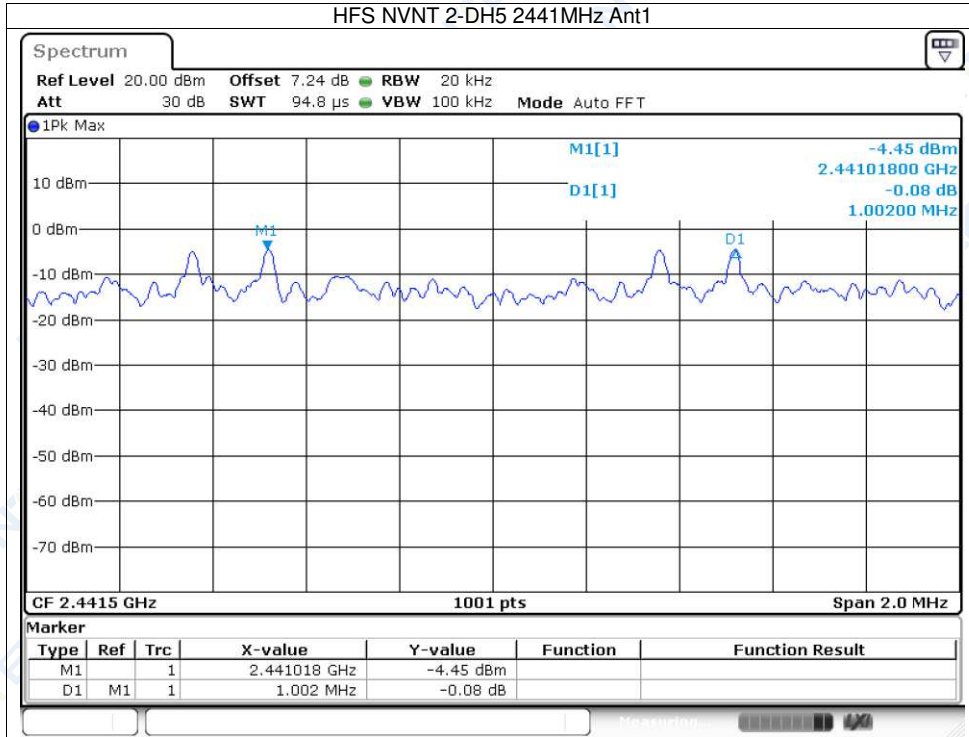

11.6 Occupied Channel Bandwidth

Condition	Mode	Frequency (MHz)	Antenna	Center Frequency (MHz)	OBW (MHz)	Lower Edge (MHz)	Upper Edge (MHz)	Limit OBW (MHz)	Verdict
NVNT	1-DH5	2402	Ant1	2402.021	0.894	2401.574	2402.468	2400 - 2483.5MHz	Pass
NVNT	1-DH5	2480	Ant1	2480.022	0.902	2479.571	2480.474	2400 - 2483.5MHz	Pass
NVNT	2-DH5	2402	Ant1	2402.02	1.196	2401.422	2402.618	2400 - 2483.5MHz	Pass
NVNT	2-DH5	2480	Ant1	2480.02	1.186	2479.427	2480.613	2400 - 2483.5MHz	Pass

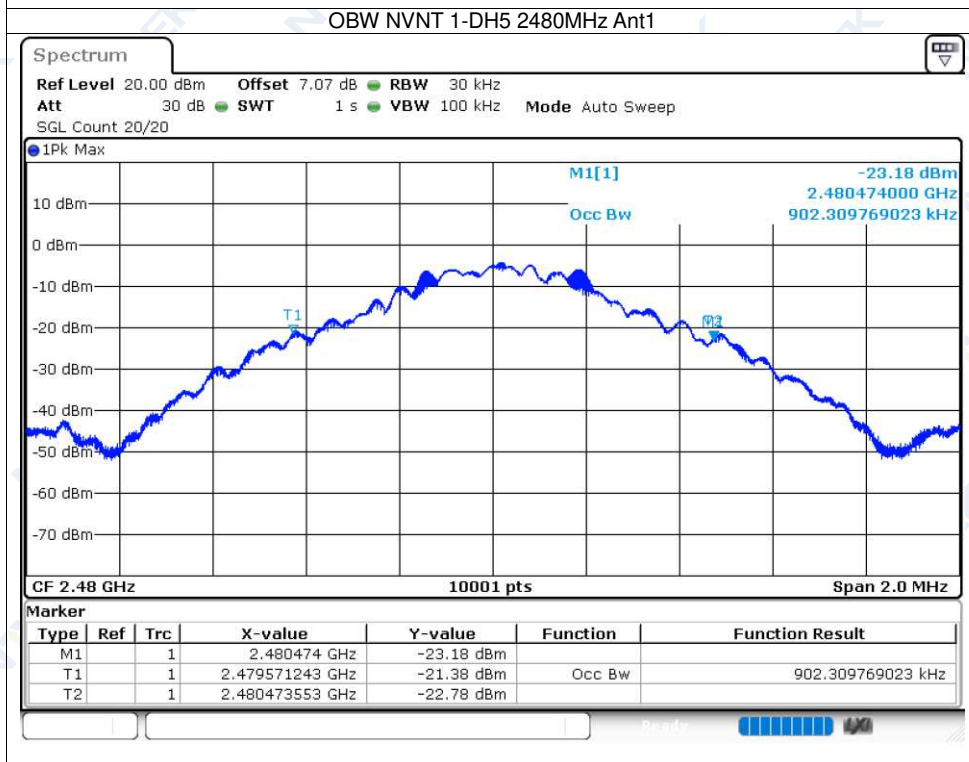
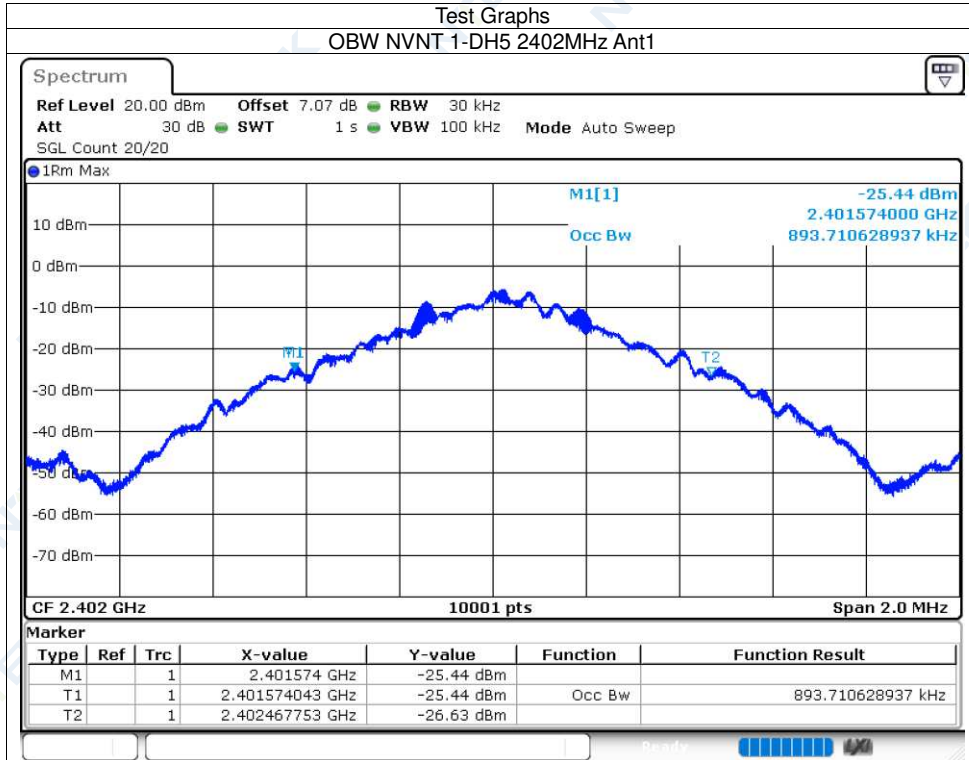

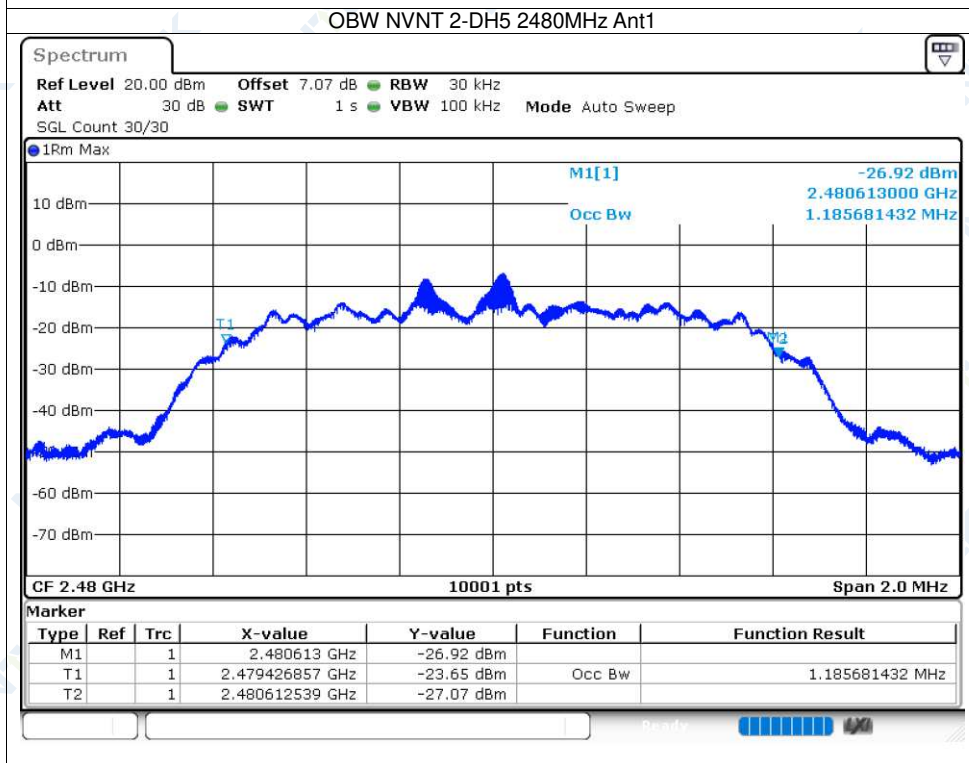
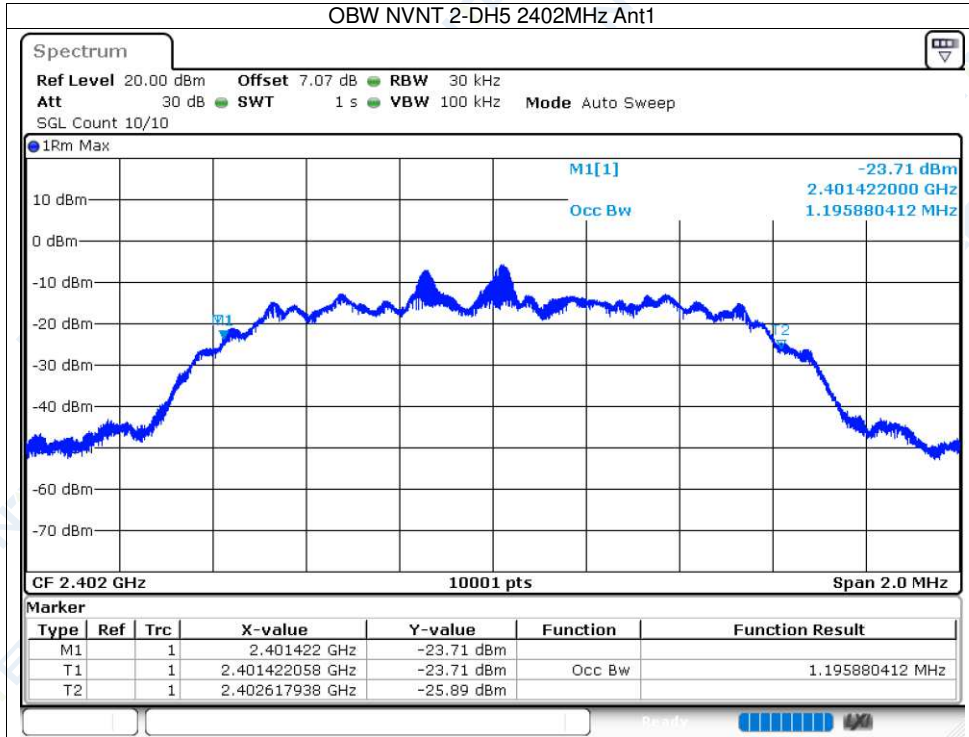

11.7 Transmitter unwanted emissions in the out-of-band domain

Condition	Mode	Frequency (MHz)	Antenna	OOB Frequency (MHz)	Level (dBm/MHz)	Limit (dBm/MHz)	Verdict
NVNT	1-DH5	Hopping	Ant1	2399.5	-46.42	-10	Pass
NVNT	1-DH5	Hopping	Ant1	2398.5	-45.93	-20	Pass
NVNT	1-DH5	Hopping	Ant1	2484	-45.73	-10	Pass
NVNT	1-DH5	Hopping	Ant1	2485	-45.74	-20	Pass
NVNT	1-DH5	Hopping	Ant1	2399.5	-46.46	-10	Pass
NVNT	1-DH5	Hopping	Ant1	2484	-45.77	-10	Pass
NVNT	1-DH5	Hopping	Ant1	2485	-45.78	-20	Pass
NVNT	2-DH5	Hopping	Ant1	2399.5	-46.46	-10	Pass
NVNT	2-DH5	Hopping	Ant1	2398.5	-45.94	-20	Pass
NVNT	2-DH5	Hopping	Ant1	2484	-45.77	-10	Pass
NVNT	2-DH5	Hopping	Ant1	2485	-45.78	-20	Pass
NVNT	2-DH5	Hopping	Ant1	2399.5	-46.44	-10	Pass
NVNT	2-DH5	Hopping	Ant1	2398.5	-45.95	-20	Pass
NVNT	2-DH5	Hopping	Ant1	2484	-45.76	-10	Pass
NVNT	2-DH5	Hopping	Ant1	2485	-45.76	-20	Pass

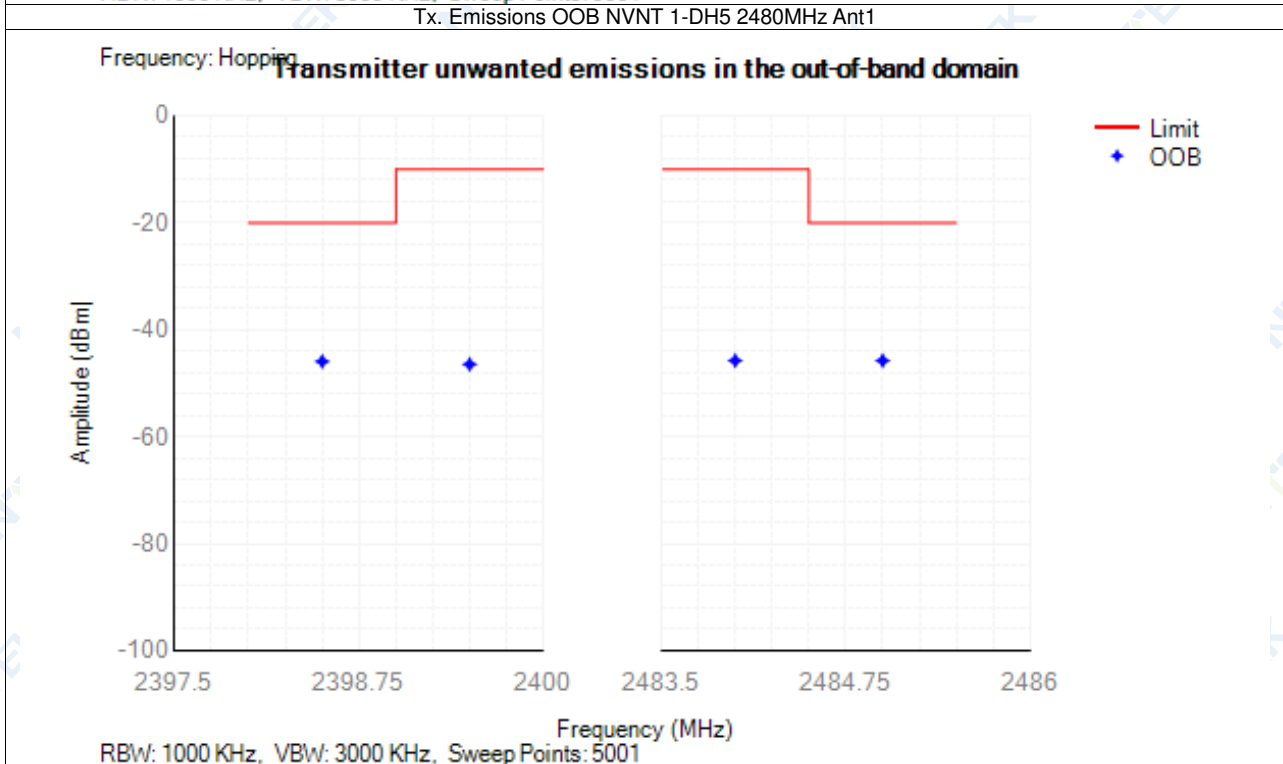
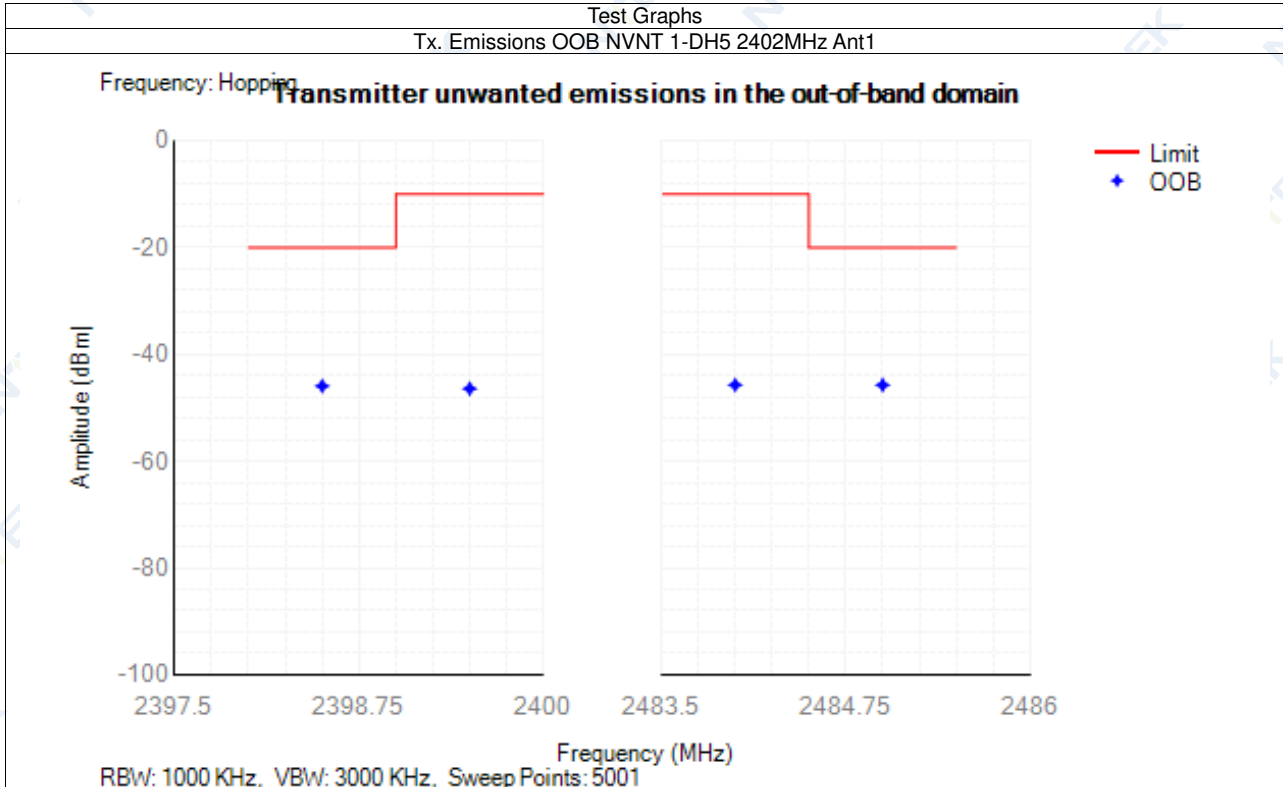

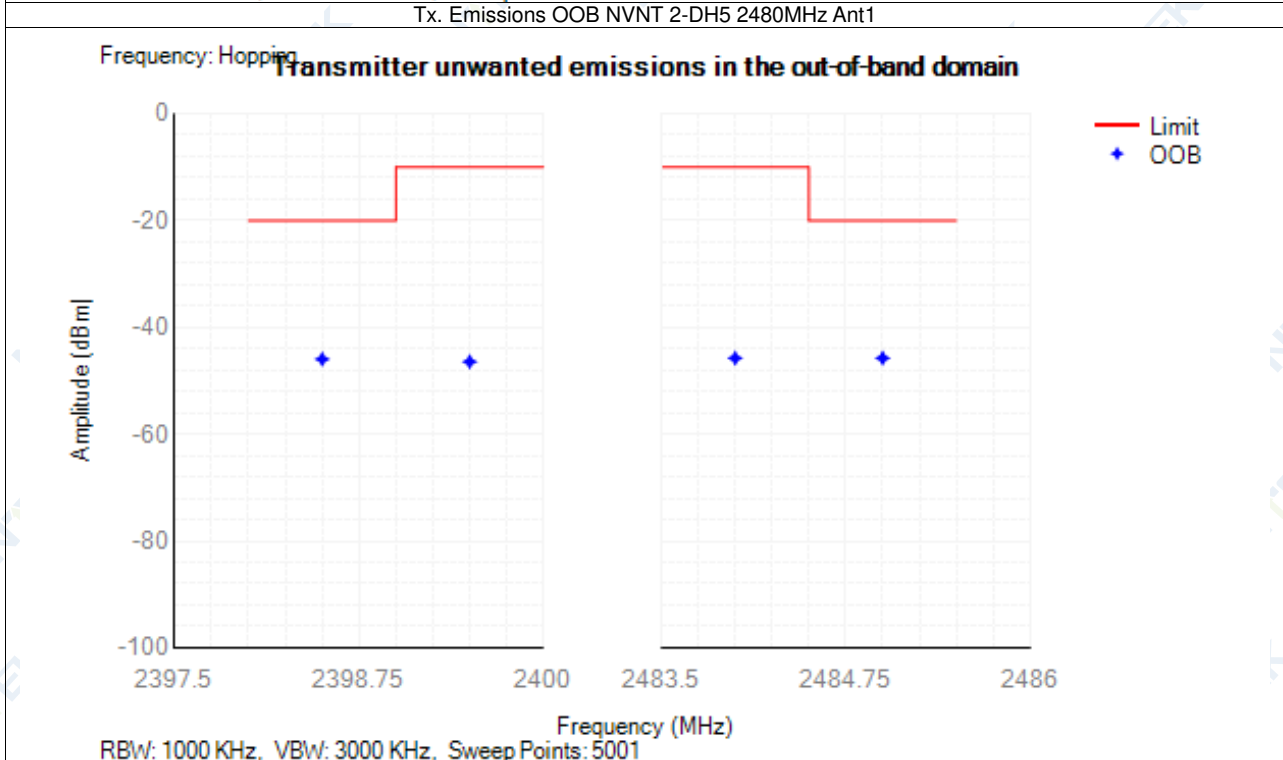
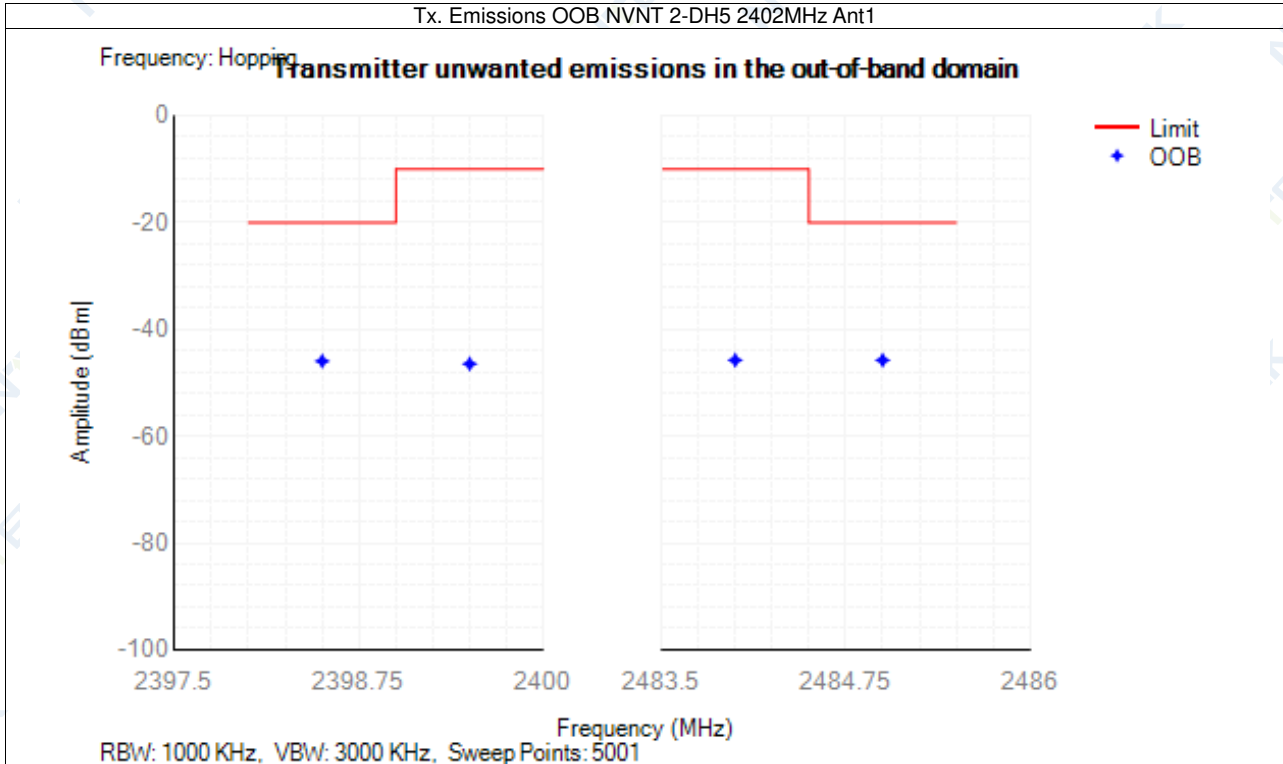

11.8 Transmitter unwanted emissions in the spurious domain

Condition	Mode	Frequency (MHz)	Antenna	Range (MHz)	Spur Freq (MHz)	Peak (dBm)	RMS (dBm)	Limit (dBm)	Verdict
NVNT	1-DH5	2402	Ant1	30 -47	39.20	-76.13	NA	-36	Pass
NVNT	1-DH5	2402	Ant1	47 -74	73.06	-75.98	NA	-54	Pass
NVNT	1-DH5	2402	Ant1	74 -87.5	87.02	-76.58	NA	-36	Pass
NVNT	1-DH5	2402	Ant1	87.5 -118	117.33	-75.91	NA	-54	Pass
NVNT	1-DH5	2402	Ant1	118 -174	157.79	-74.73	NA	-36	Pass
NVNT	1-DH5	2402	Ant1	174 -230	192.05	-75.01	NA	-54	Pass
NVNT	1-DH5	2402	Ant1	230 -470	345.55	-73.99	NA	-36	Pass
NVNT	1-DH5	2402	Ant1	470 -694	682.80	-74.15	NA	-54	Pass
NVNT	1-DH5	2402	Ant1	694 -1000	921.93	-73.90	NA	-36	Pass
NVNT	1-DH5	2402	Ant1	1000 -2398	2209.50	-46.11	NA	-30	Pass
NVNT	1-DH5	2402	Ant1	2485.5 -12750	4804.00	-44.30	NA	-30	Pass
NVNT	1-DH5	534.65	Ant1	30 -47	34.90	-75.93	NA	-36	Pass
NVNT	1-DH5	534.65	Ant1	47 -74	70.20	-76.08	NA	-54	Pass
NVNT	1-DH5	534.65	Ant1	74 -87.5	75.70	-76.44	NA	-36	Pass
NVNT	1-DH5	534.65	Ant1	87.5 -118	111.00	-75.82	NA	-54	Pass
NVNT	1-DH5	534.65	Ant1	118 -174	156.00	-75.03	NA	-36	Pass
NVNT	1-DH5	534.65	Ant1	174 -230	201.60	-74.82	NA	-54	Pass
NVNT	1-DH5	534.65	Ant1	230 -470	466.00	-73.82	NA	-36	Pass
NVNT	1-DH5	534.65	Ant1	470 -694	519.10	-74.56	NA	-54	Pass
NVNT	1-DH5	534.65	Ant1	694 -1000	945.85	-73.40	NA	-36	Pass
NVNT	1-DH5	534.65	Ant1	1000 -2398	2249.00	-45.75	NA	-30	Pass
NVNT	1-DH5	534.65	Ant1	2485.5 -12750	4882.00	-44.01	NA	-30	Pass
NVNT	1-DH5	2480	Ant1	30 -47	42.55	-76.66	NA	-36	Pass
NVNT	1-DH5	2480	Ant1	47 -74	66.95	-75.23	NA	-54	Pass
NVNT	1-DH5	2480	Ant1	74 -87.5	80.90	-76.39	NA	-36	Pass
NVNT	1-DH5	2480	Ant1	87.5 -118	109.15	-76.12	NA	-54	Pass
NVNT	1-DH5	2480	Ant1	118 -174	169.85	-75.46	NA	-36	Pass
NVNT	1-DH5	2480	Ant1	174 -230	216.65	-74.78	NA	-54	Pass
NVNT	1-DH5	2480	Ant1	230 -470	288.05	-71.72	NA	-36	Pass
NVNT	1-DH5	2480	Ant1	470 -694	584.80	-74.36	NA	-54	Pass
NVNT	1-DH5	2480	Ant1	694 -1000	875.70	-73.69	NA	-36	Pass
NVNT	1-DH5	2480	Ant1	1000 -2398	2288.00	-44.95	NA	-30	Pass
NVNT	1-DH5	2480	Ant1	2485.5 -12750	4959.50	-44.13	NA	-30	Pass
NVNT	2-DH5	2402	Ant1	30 -47	30.20	-76.13	NA	-36	Pass
NVNT	2-DH5	2402	Ant1	47 -74	71.90	-76.13	NA	-54	Pass
NVNT	2-DH5	2402	Ant1	74 -87.5	87.10	-75.97	NA	-36	Pass
NVNT	2-DH5	2402	Ant1	87.5 -118	96.80	-76.01	NA	-54	Pass
NVNT	2-DH5	2402	Ant1	118 -174	144.00	-74.15	NA	-36	Pass
NVNT	2-DH5	2402	Ant1	174 -230	191.95	-74.98	NA	-54	Pass
NVNT	2-DH5	2402	Ant1	230 -470	334.05	-74.65	NA	-36	Pass
NVNT	2-DH5	2402	Ant1	470 -694	585.55	-74.17	NA	-54	Pass
NVNT	2-DH5	2402	Ant1	694 -1000	699.25	-69.32	NA	-36	Pass
NVNT	2-DH5	2402	Ant1	1000 -2398	2210.00	-46.79	NA	-30	Pass
NVNT	2-DH5	2402	Ant1	2485.5 -12750	6998.50	-44.70	NA	-30	Pass
NVNT	2-DH5	2441	Ant1	30 -47	42.65	-76.41	NA	-36	Pass
NVNT	2-DH5	2441	Ant1	47 -74	56.35	-75.58	NA	-54	Pass
NVNT	2-DH5	2441	Ant1	74 -87.5	80.45	-76.48	NA	-36	Pass
NVNT	2-DH5	2441	Ant1	87.5 -118	96.00	-69.50	NA	-54	Pass
NVNT	2-DH5	2441	Ant1	118 -174	137.55	-74.85	NA	-36	Pass
NVNT	2-DH5	2441	Ant1	174 -230	191.95	-74.39	NA	-54	Pass
NVNT	2-DH5	2441	Ant1	230 -470	288.00	-71.46	NA	-36	Pass
NVNT	2-DH5	2441	Ant1	470 -694	635.45	-74.63	NA	-54	Pass
NVNT	2-DH5	2441	Ant1	694 -1000	711.40	-67.63	NA	-36	Pass
NVNT	2-DH5	2441	Ant1	1000 -2398	2248.50	-46.47	NA	-30	Pass
NVNT	2-DH5	2441	Ant1	2485.5 -12750	4882.00	-45.14	NA	-30	Pass
NVNT	2-DH5	2480	Ant1	30 -47	41.90	-75.54	NA	-36	Pass
NVNT	2-DH5	2480	Ant1	47 -74	52.10	-75.88	NA	-54	Pass
NVNT	2-DH5	2480	Ant1	74 -87.5	82.35	-76.41	NA	-36	Pass
NVNT	2-DH5	2480	Ant1	87.5 -118	108.30	-75.82	NA	-54	Pass
NVNT	2-DH5	2480	Ant1	118 -174	168.45	-74.13	NA	-36	Pass
NVNT	2-DH5	2480	Ant1	174 -230	227.65	-74.44	NA	-54	Pass
NVNT	2-DH5	2480	Ant1	230 -470	288.05	-71.47	NA	-36	Pass
NVNT	2-DH5	2480	Ant1	470 -694	638.10	-74.74	NA	-54	Pass
NVNT	2-DH5	2480	Ant1	694 -1000	961.75	-73.27	NA	-36	Pass
NVNT	2-DH5	2480	Ant1	1000 -2398	2288.00	-45.08	NA	-30	Pass
NVNT	2-DH5	2480	Ant1	2485.5 -12750	4960.00	-45.00	NA	-30	Pass

Test Graphs

Tx. Spurious NVNT 1-DH5 2402MHz Ant1

Frequency: 2402 MHz

Transmitter unwanted emissions in the spurious domain

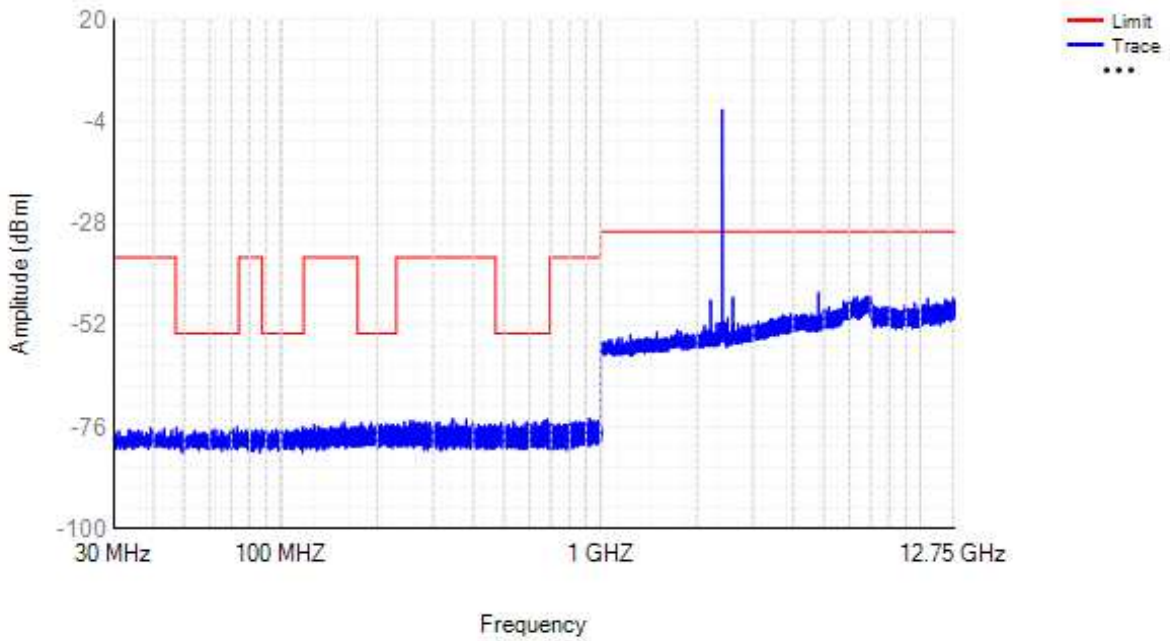

Tx. Spurious NVNT 1-DH5 534.65MHz Ant1

Frequency: 534.65 MHz

Transmitter unwanted emissions in the spurious domain

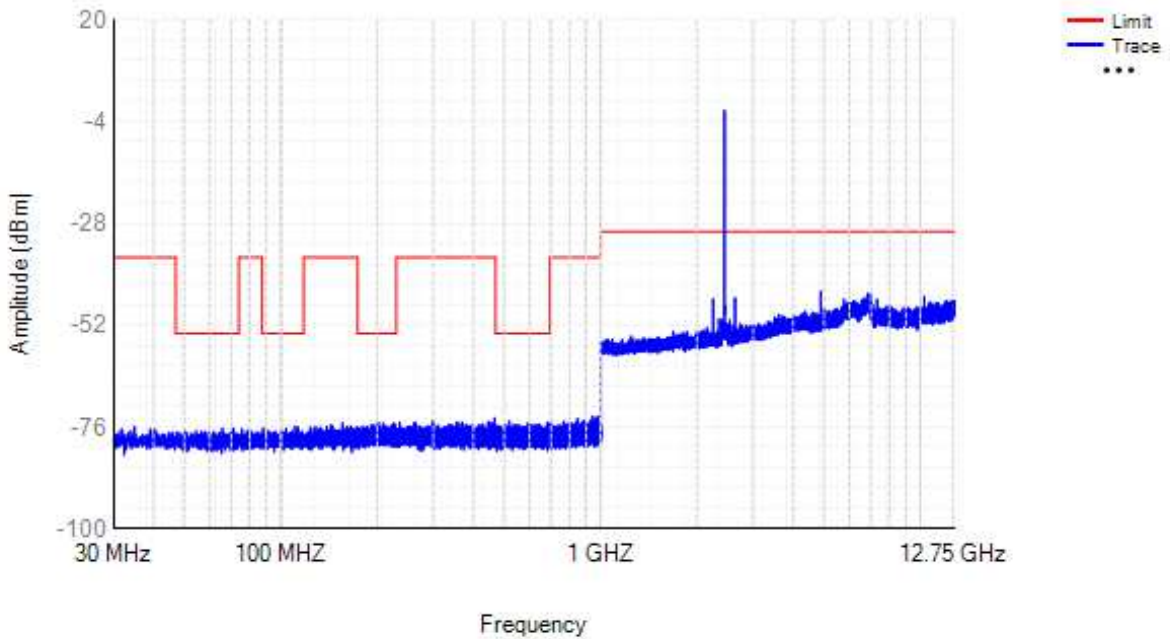

Tx. Spurious NVNT 1-DH5 2480MHz Ant1

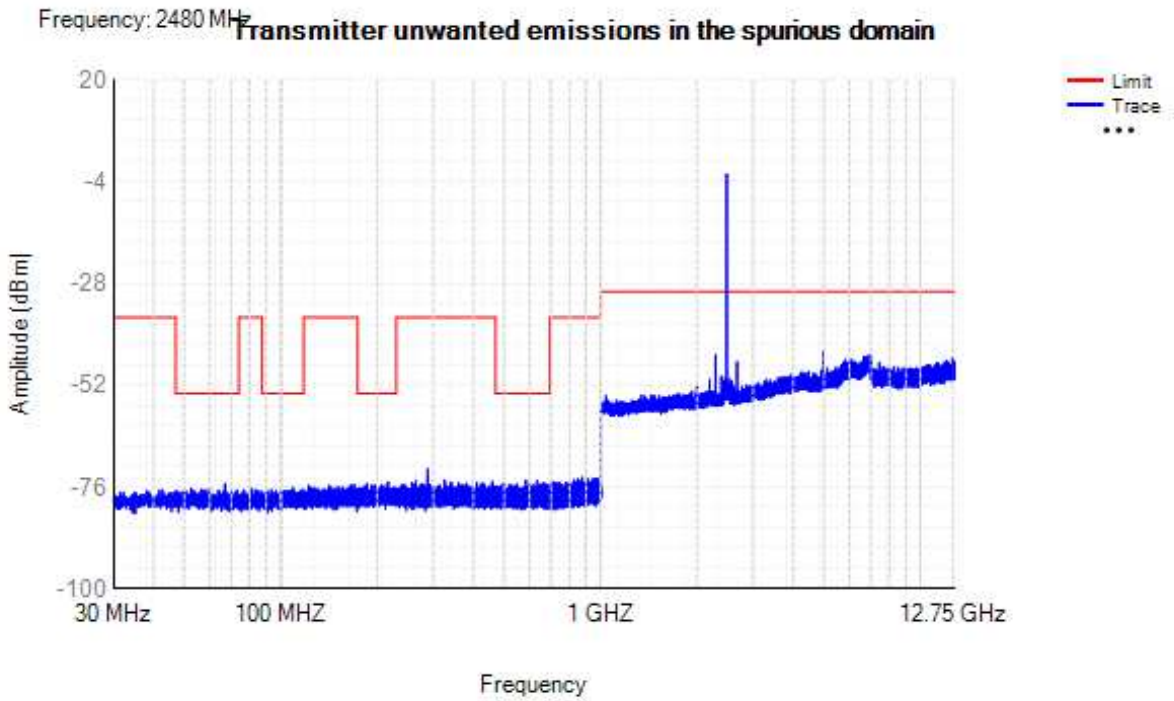

Tx. Spurious NVNT 2-DH5 2402MHz Ant1

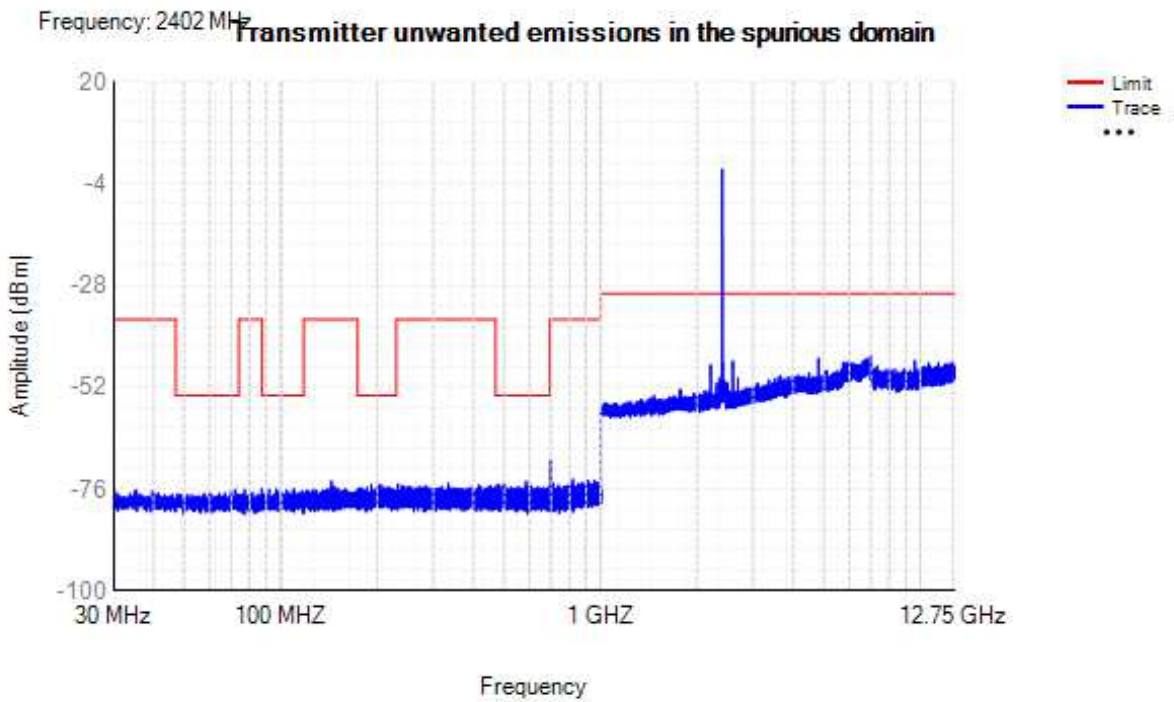

Tx. Spurious NVNT 2-DH5 2441MHz Ant1

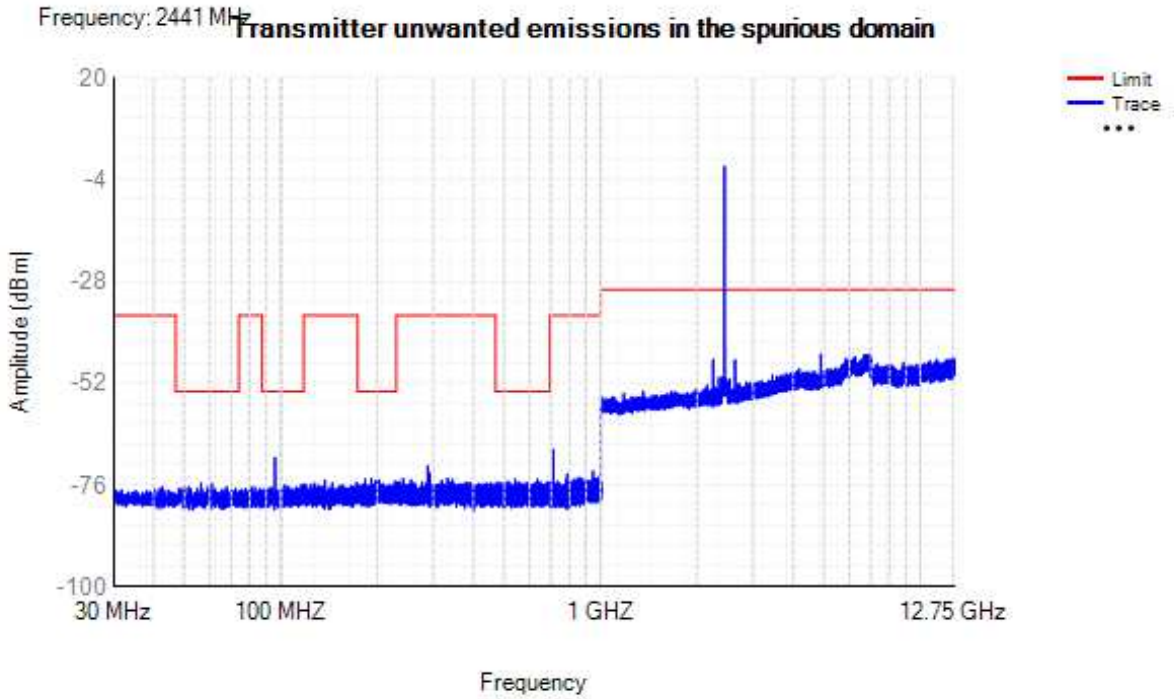

Tx. Spurious NVNT 2-DH5 2480MHz Ant1

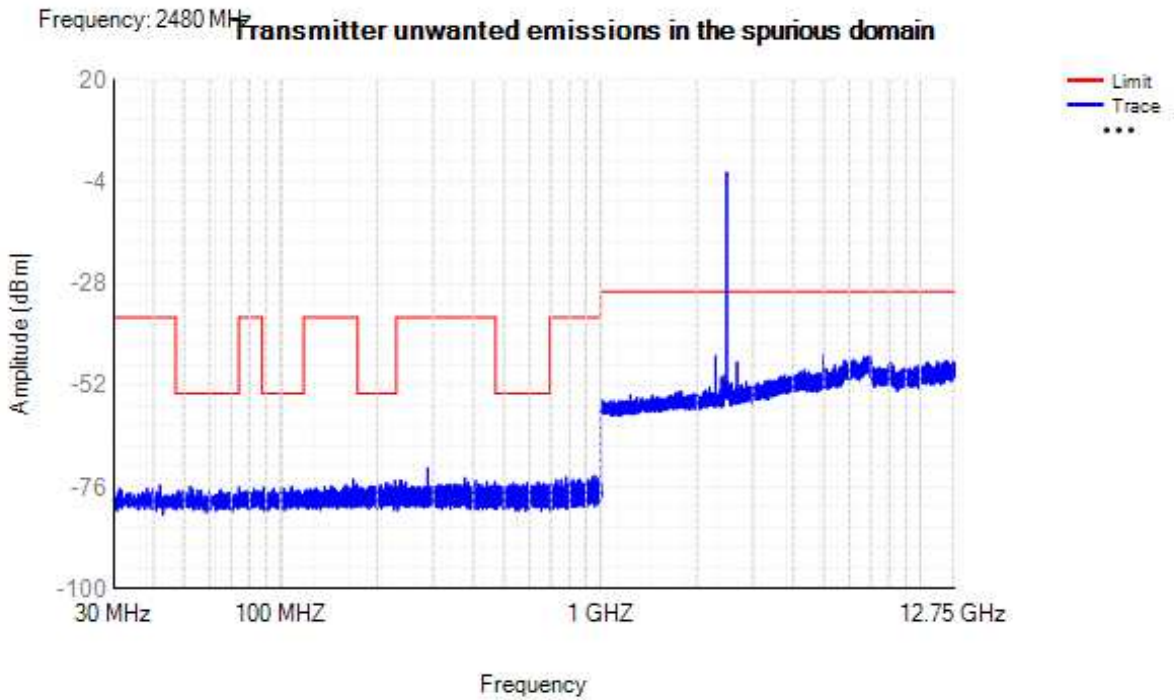

11.9 Receiver spurious emissions

Condition	Mode	Frequency (MHz)	Antenna	Range (MHz)	Spur Freq (MHz)	Peak (dBm)	RMS (dBm)	Limit (dBm)	Verdict
NVNT	1-DH5	2402	Ant1	30 -1000	978.15	-74.46	NA	-57	Pass
NVNT	1-DH5	2402	Ant1	1000 -12750	6736.5	-55.93	NA	-47	Pass
NVNT	1-DH5	2441	Ant1	30 -1000	373.25	-74.01	NA	-57	Pass
NVNT	1-DH5	2441	Ant1	1000 -12750	5846	-55.66	NA	-47	Pass
NVNT	1-DH5	2480	Ant1	30 -1000	967.85	-74.34	NA	-57	Pass
NVNT	1-DH5	2480	Ant1	1000 -12750	6806	-55.59	NA	-47	Pass
NVNT	2-DH5	2402	Ant1	30 -1000	914.4	-74.71	NA	-57	Pass
NVNT	2-DH5	2402	Ant1	1000 -12750	6957.5	-54.82	NA	-47	Pass
NVNT	2-DH5	2441	Ant1	30 -1000	617.55	-74.59	NA	-57	Pass
NVNT	2-DH5	2441	Ant1	1000 -12750	6734.5	-55.80	NA	-47	Pass
NVNT	2-DH5	2480	Ant1	30 -1000	927.45	-74.71	NA	-57	Pass
NVNT	2-DH5	2480	Ant1	1000 -12750	6797.5	-55.83	NA	-47	Pass

Test Graphs

Rx. Spurious NVNT 1-DH5 2402MHz Ant1

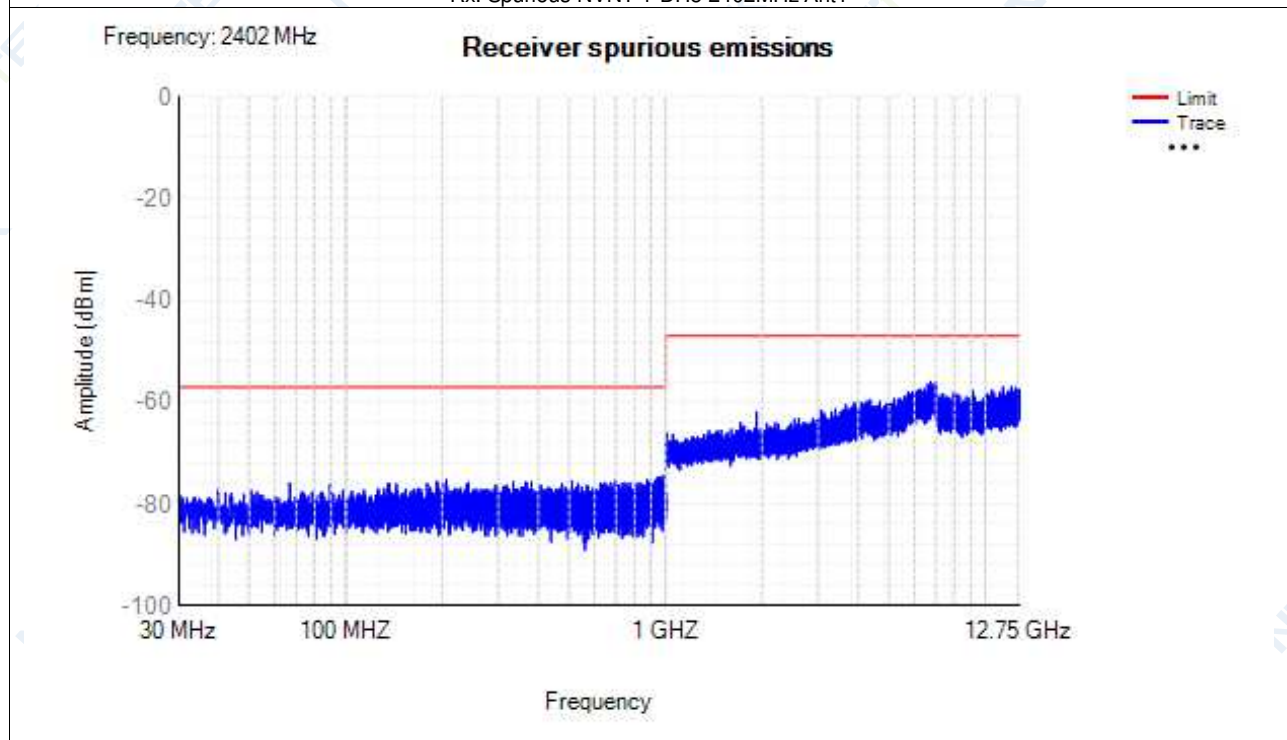

Rx. Spurious NVNT 1-DH5 2441MHz Ant1

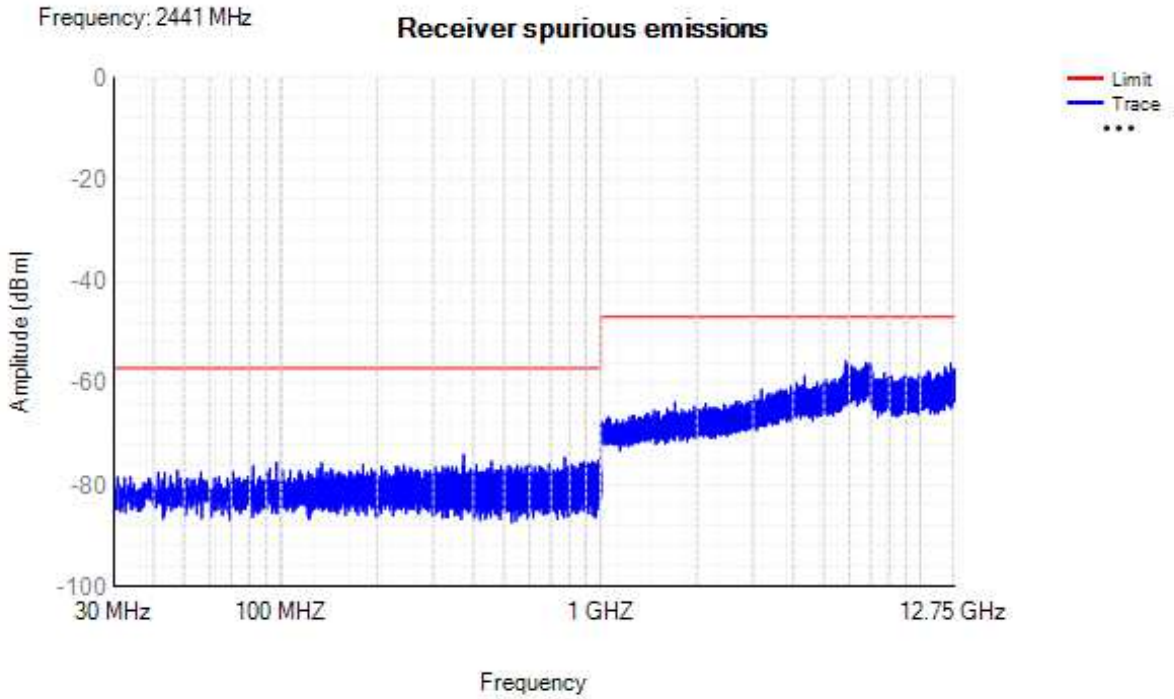

Rx. Spurious NVNT 1-DH5 2480MHz Ant1

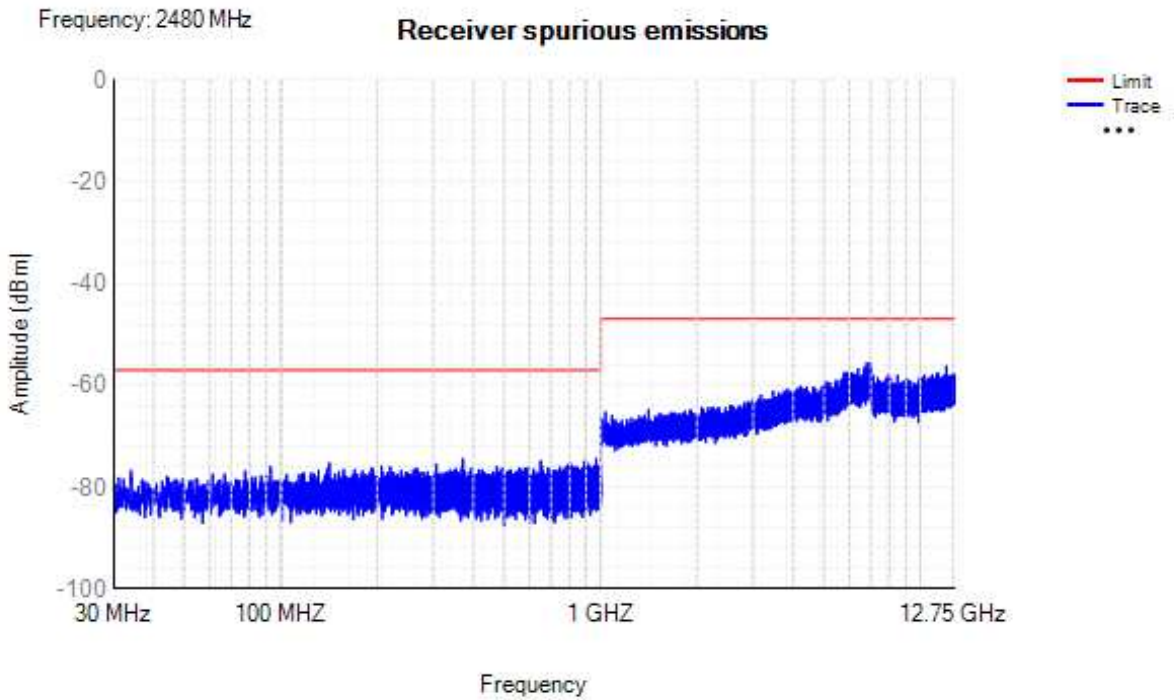

Rx. Spurious NVNT 2-DH5 2402MHz Ant1

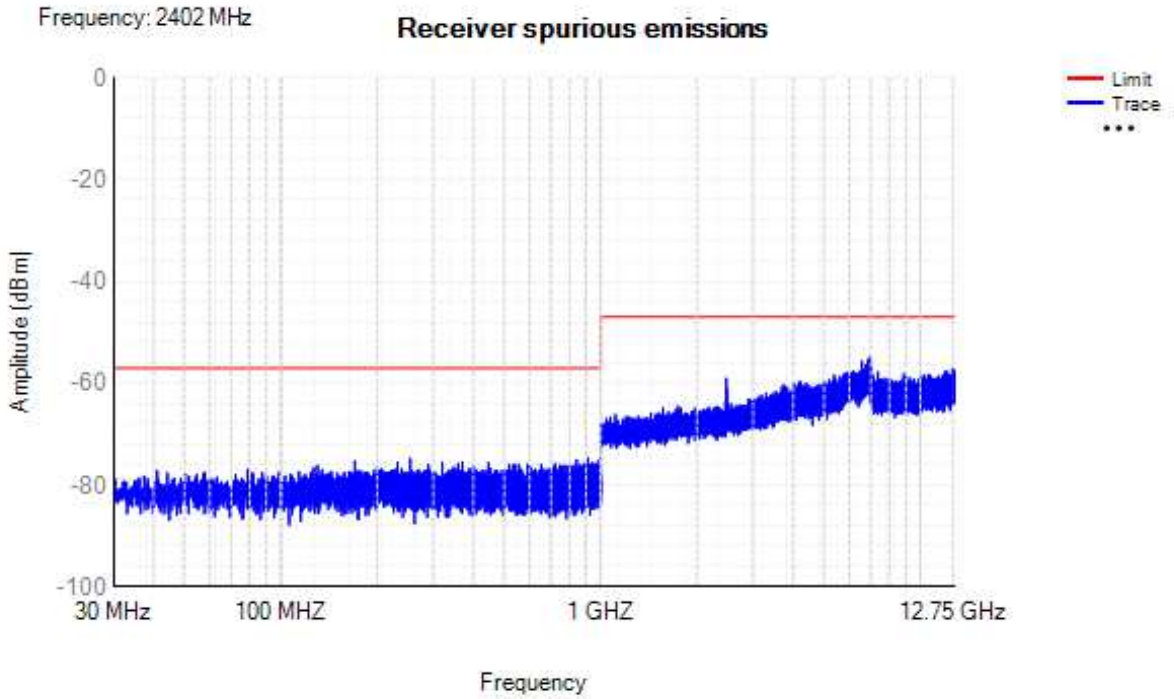

Rx. Spurious NVNT 2-DH5 2441MHz Ant1

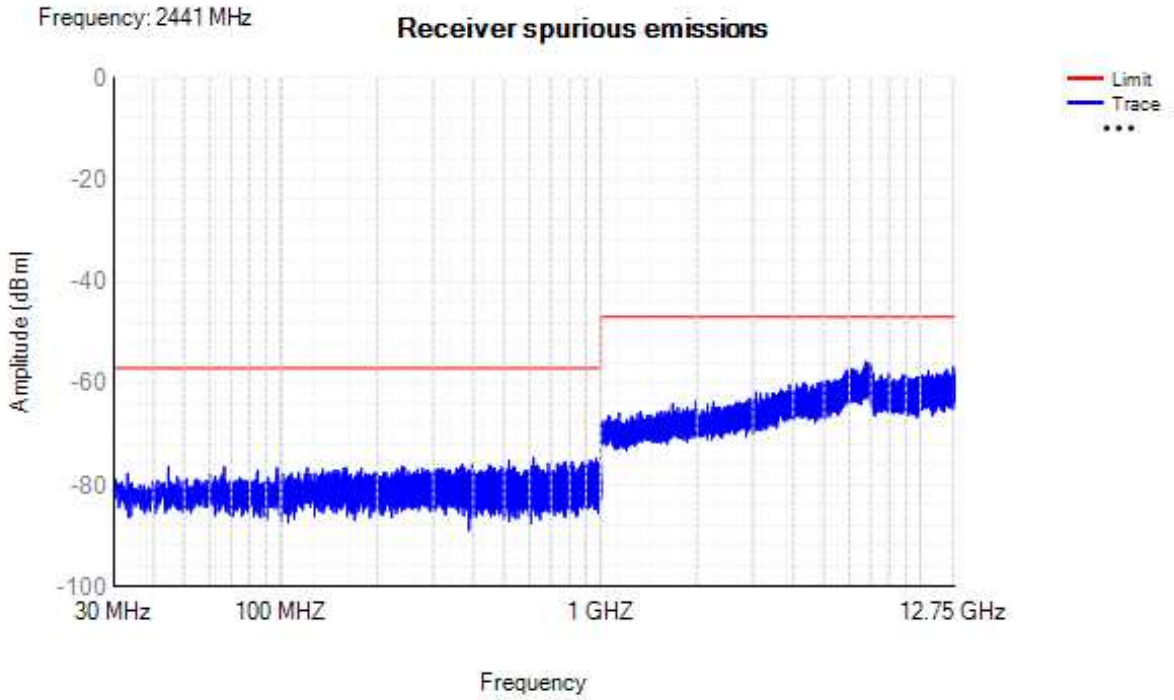

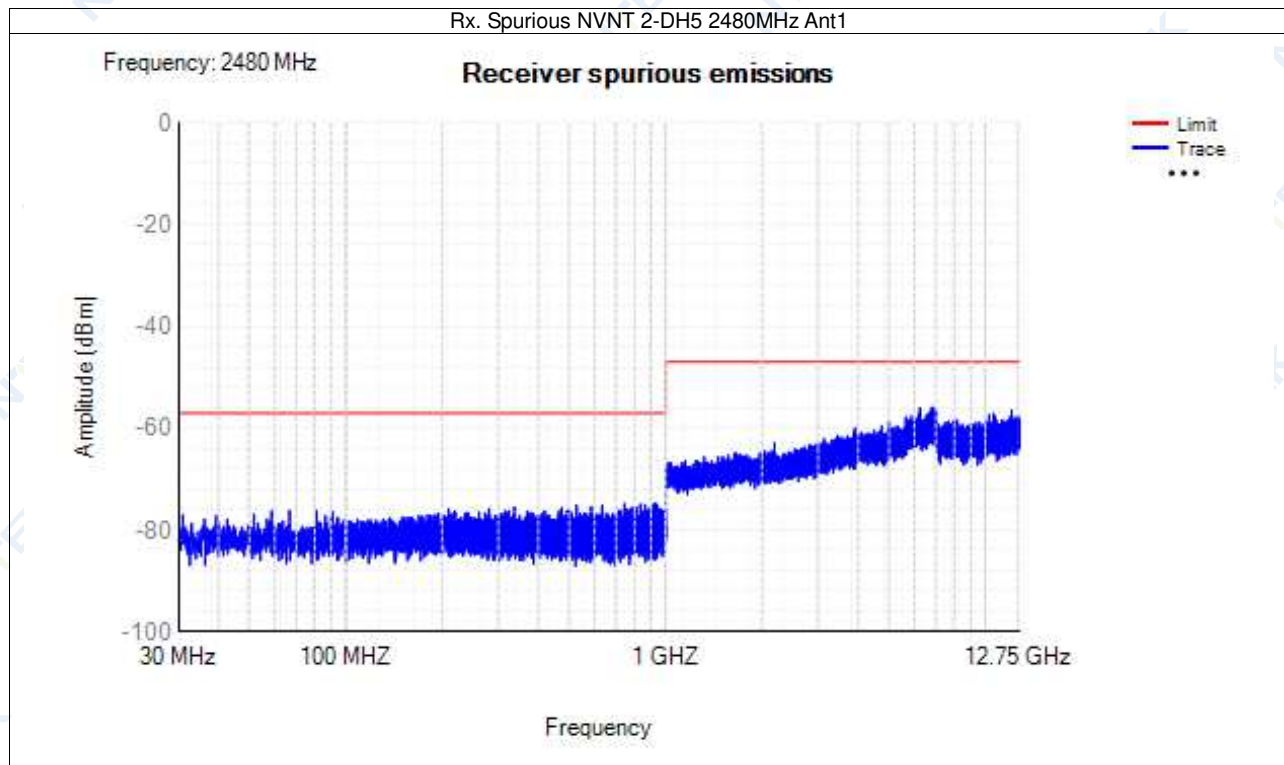

11.10 Hopping Sequence

Condition	Mode	Antenna	Hopping Number	Limit	Band Allocation (%)	Limit Band Allocation (%)	Verdict
NVNT	1-DH5	Ant1	79	15	95.6	70	Pass
NVNT	2-DH5	Ant1	79	15	96.2	70	Pass

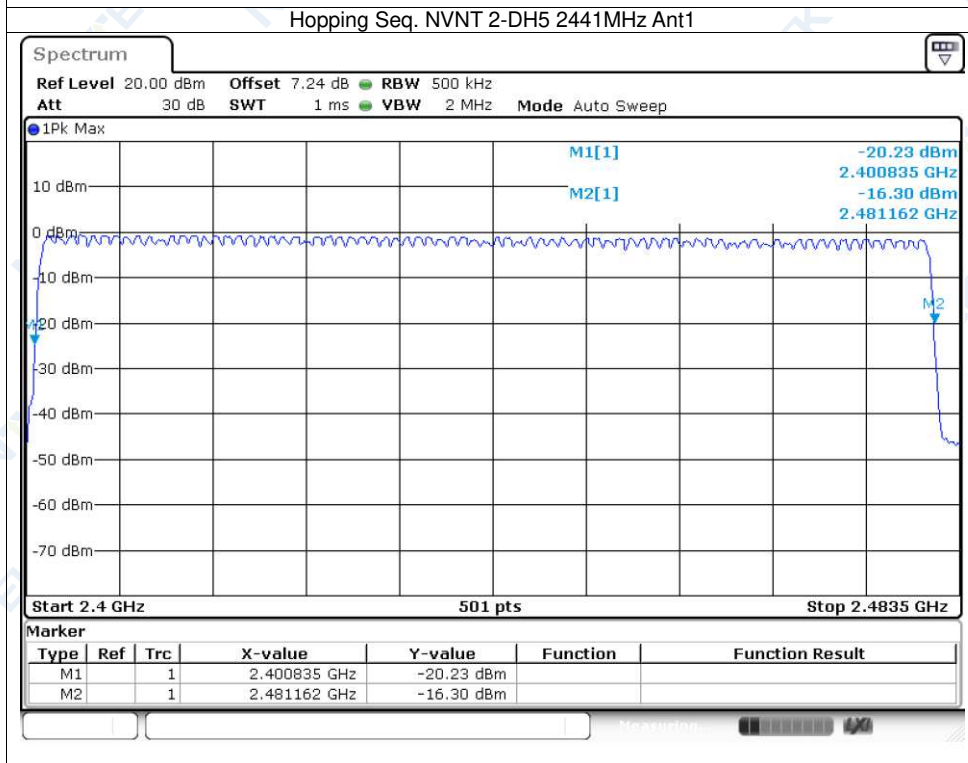
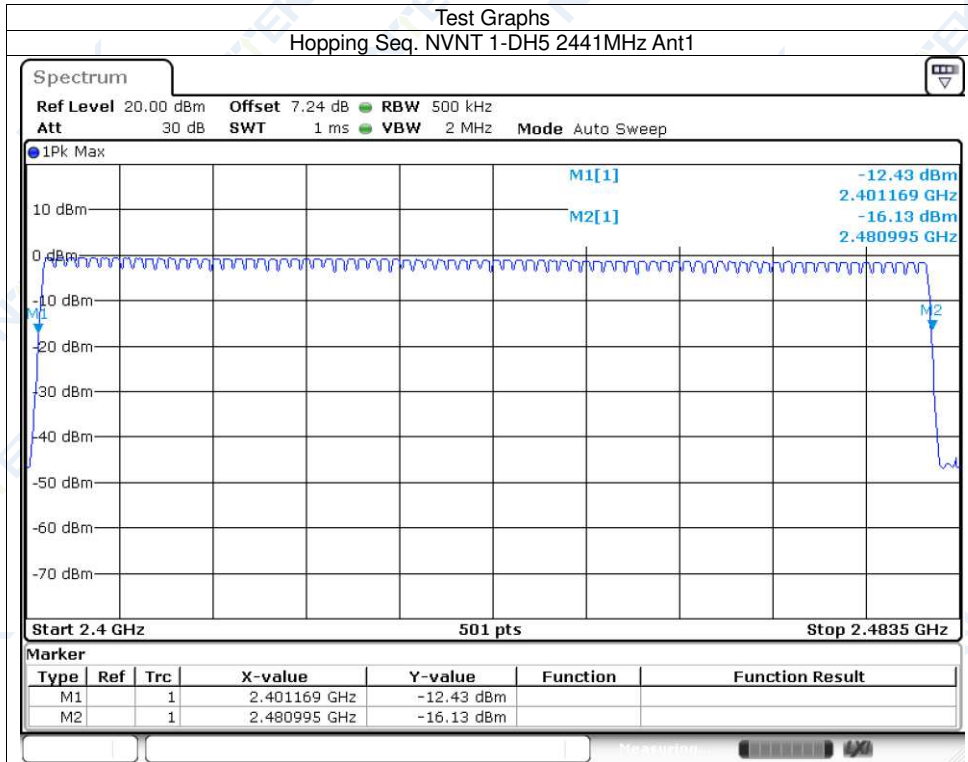

Right

11.1 Accumulated Transmit Time

Condition	Mode	Frequency (MHz)	Antenna	Accumulated Transmit Time (ms)	Limit (ms)	Sweep Time (ms)	Burst Number	Verdict
NVNT	1-DH1	2402	Ant1	121.411	400	31600	317	Pass
NVNT	1-DH1	2480	Ant1	121.476	400	31600	318	Pass
NVNT	1-DH3	2402	Ant1	276.991	400	31600	169	Pass
NVNT	1-DH3	2480	Ant1	248.976	400	31600	152	Pass
NVNT	1-DH5	2402	Ant1	308.909	400	31600	107	Pass
NVNT	1-DH5	2480	Ant1	303.03	400	31600	105	Pass
NVNT	2-DH1	2402	Ant1	124.02	400	31600	318	Pass
NVNT	2-DH1	2480	Ant1	124.729	400	31600	319	Pass
NVNT	2-DH3	2402	Ant1	262.08	400	31600	160	Pass
NVNT	2-DH3	2480	Ant1	193.992	400	31600	118	Pass
NVNT	2-DH5	2402	Ant1	328.89	400	31600	114	Pass
NVNT	2-DH5	2480	Ant1	312.336	400	31600	108	Pass

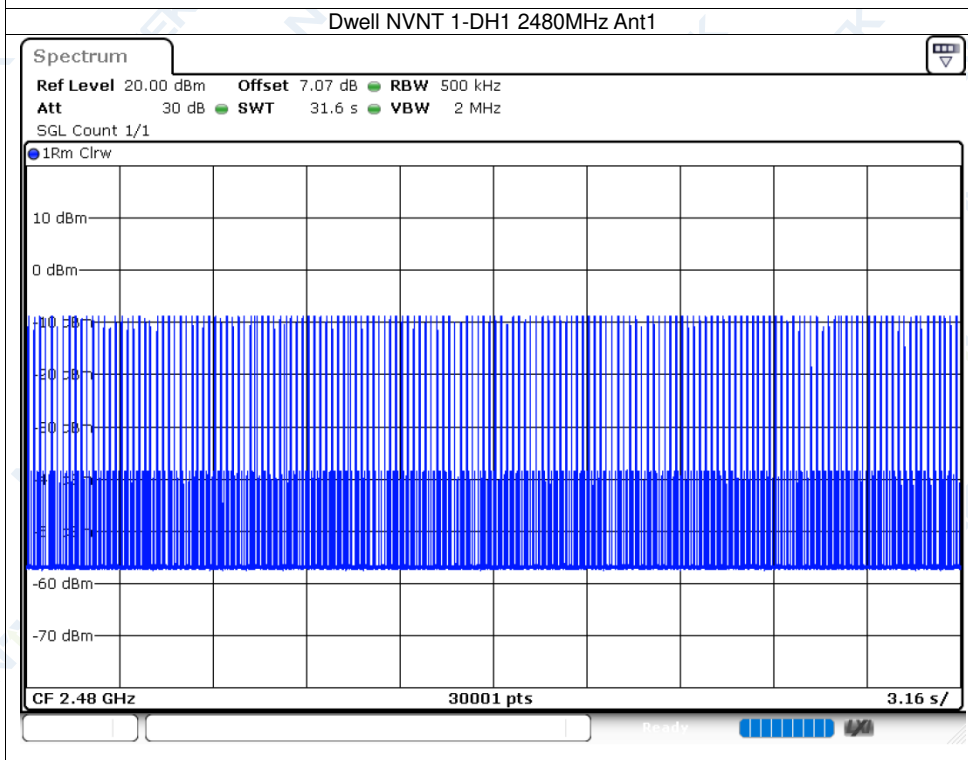
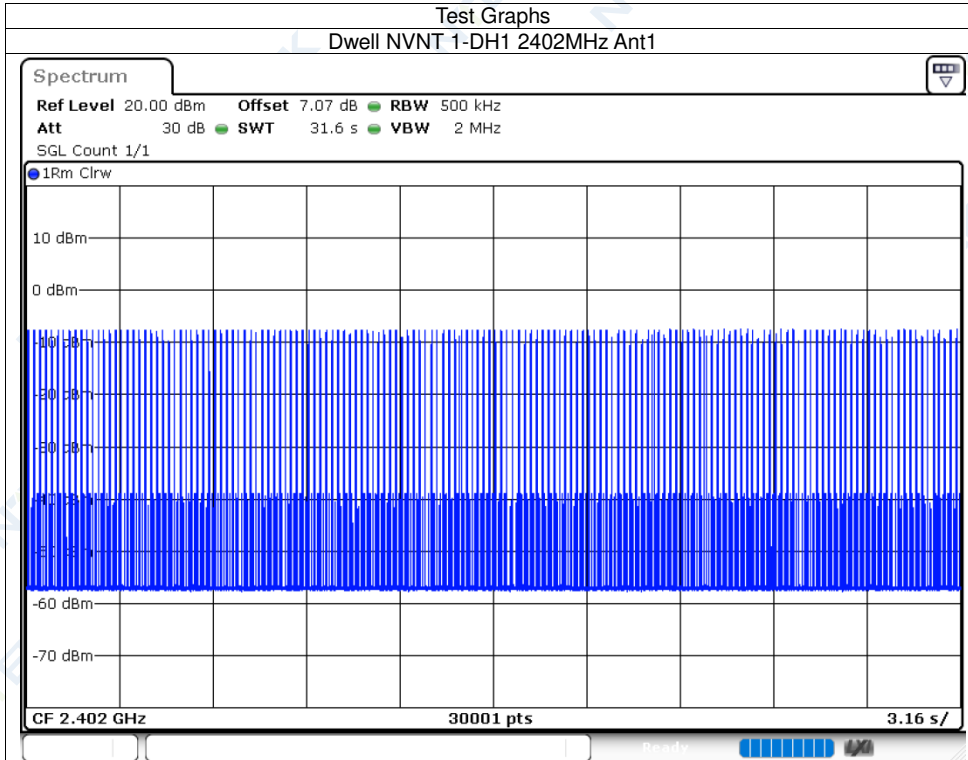

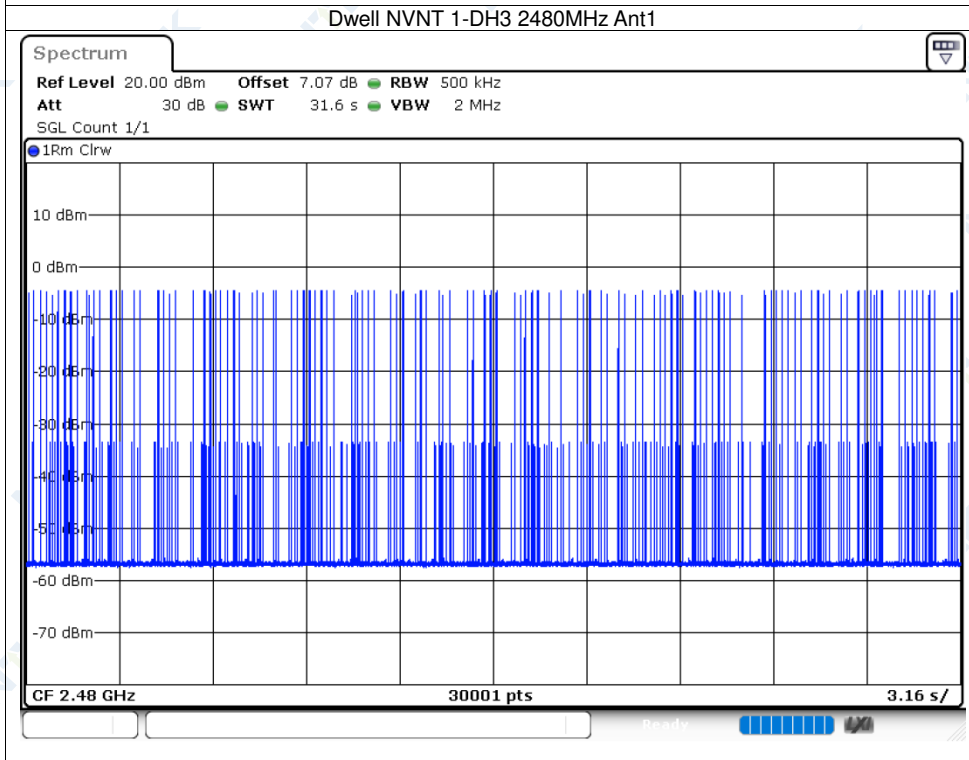
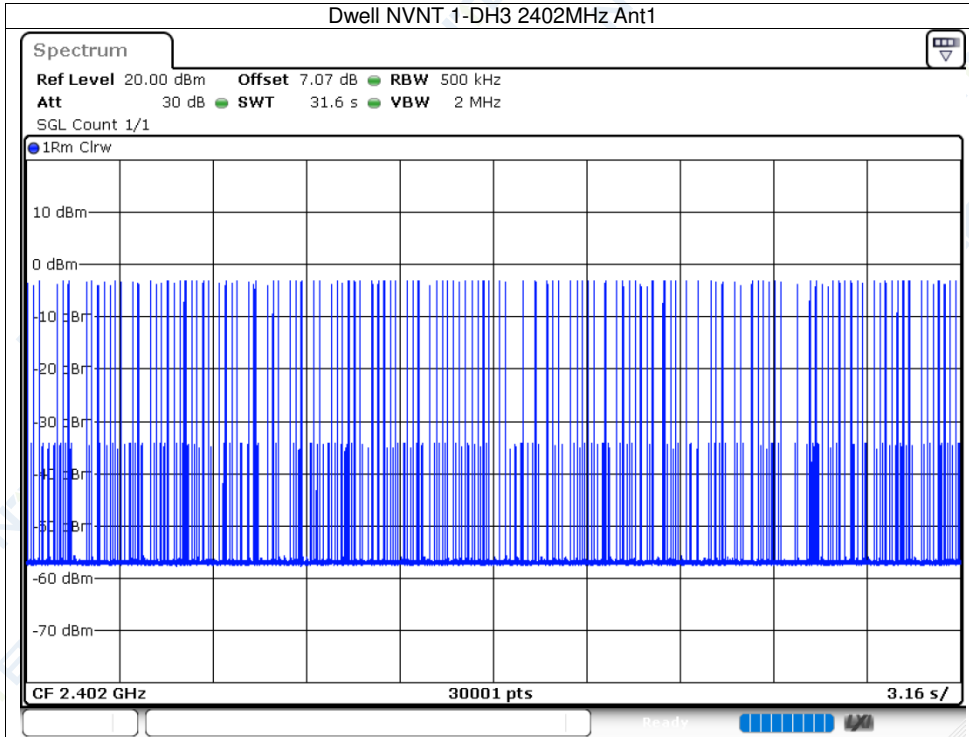

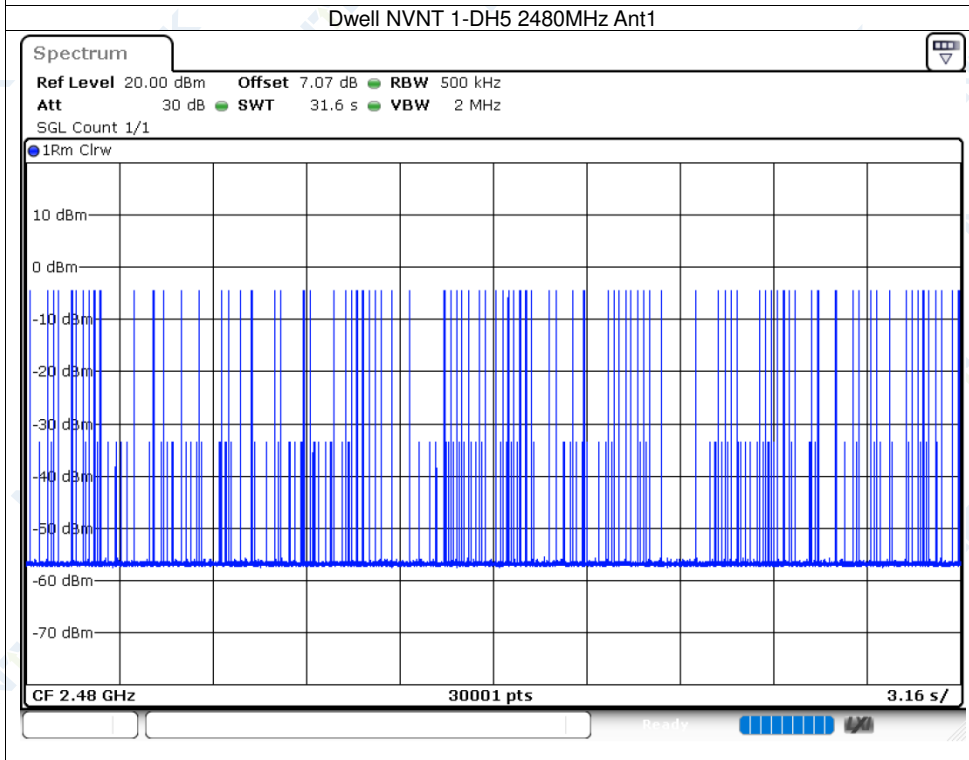
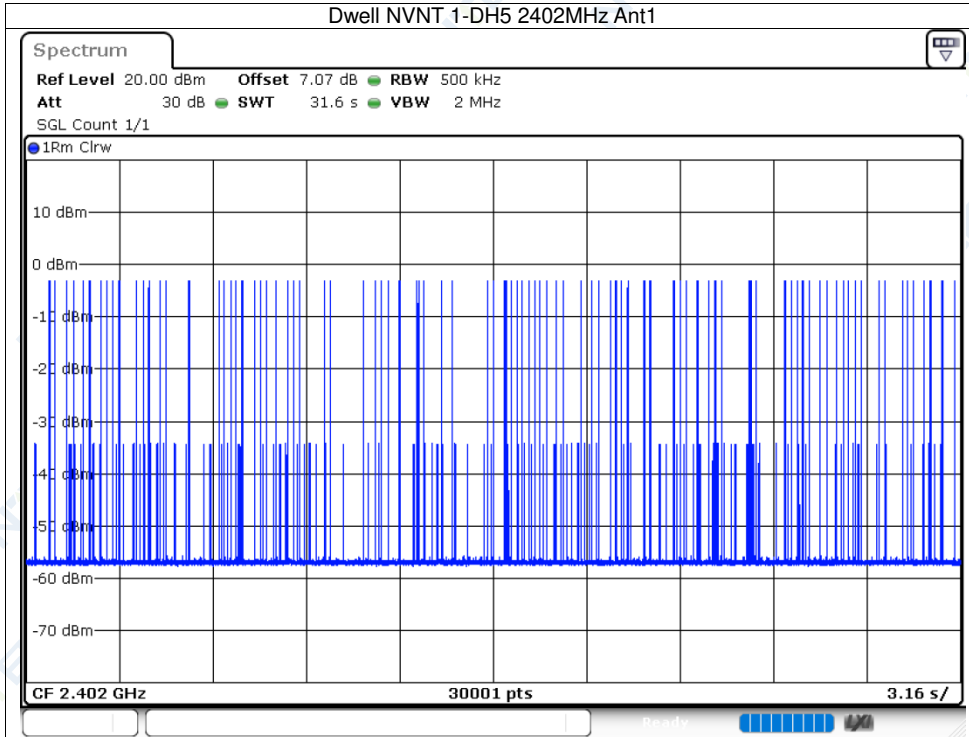

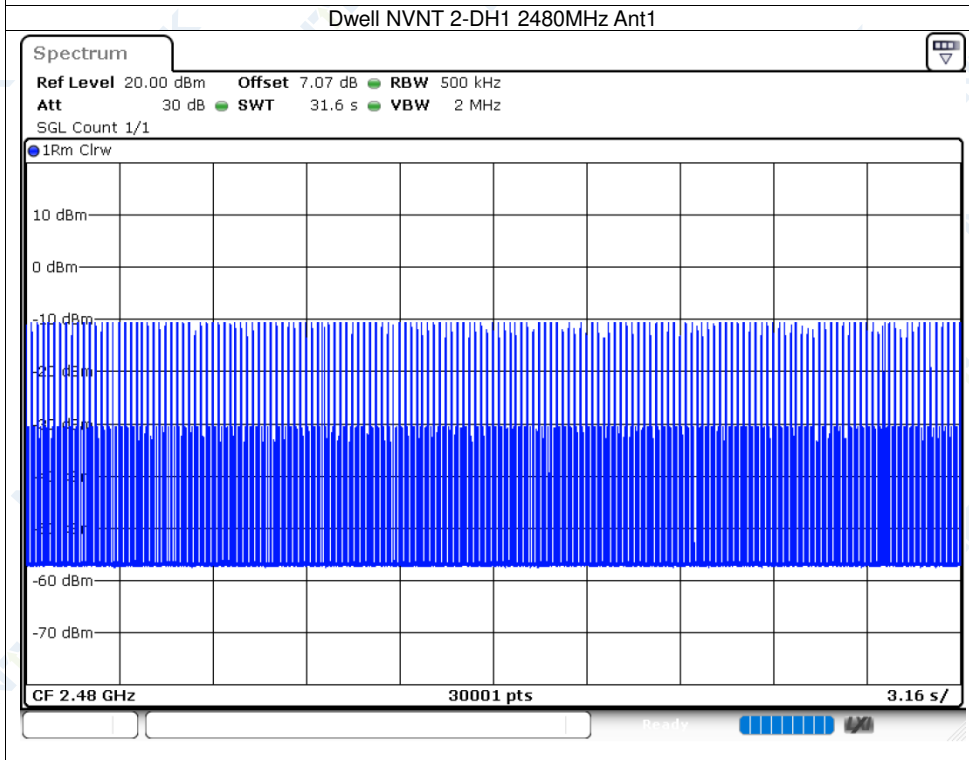
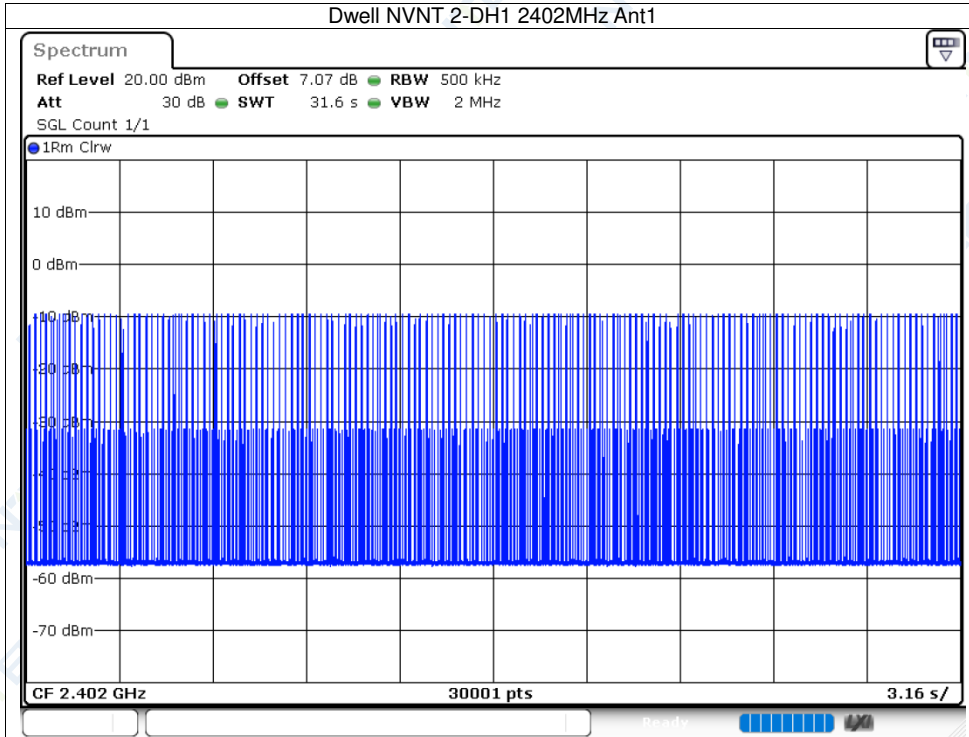

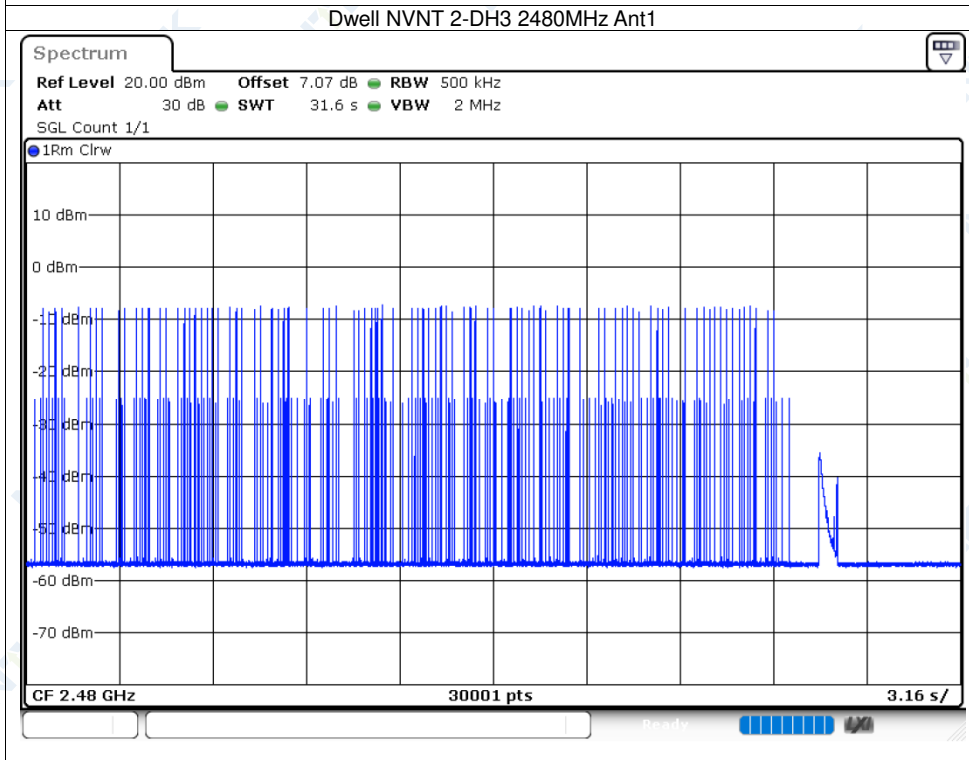
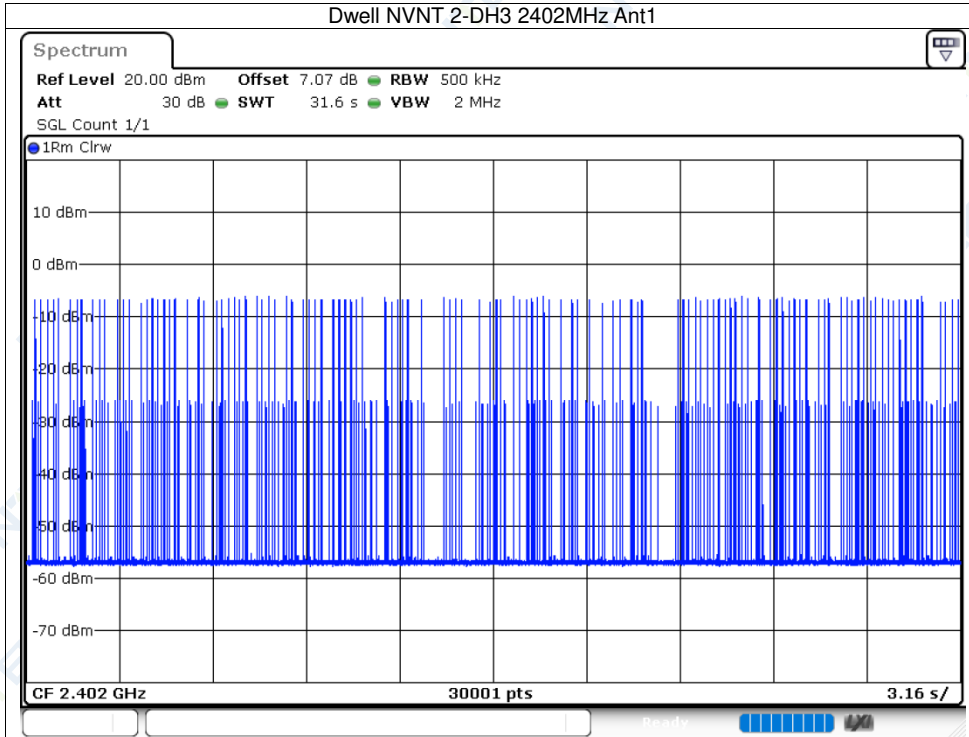

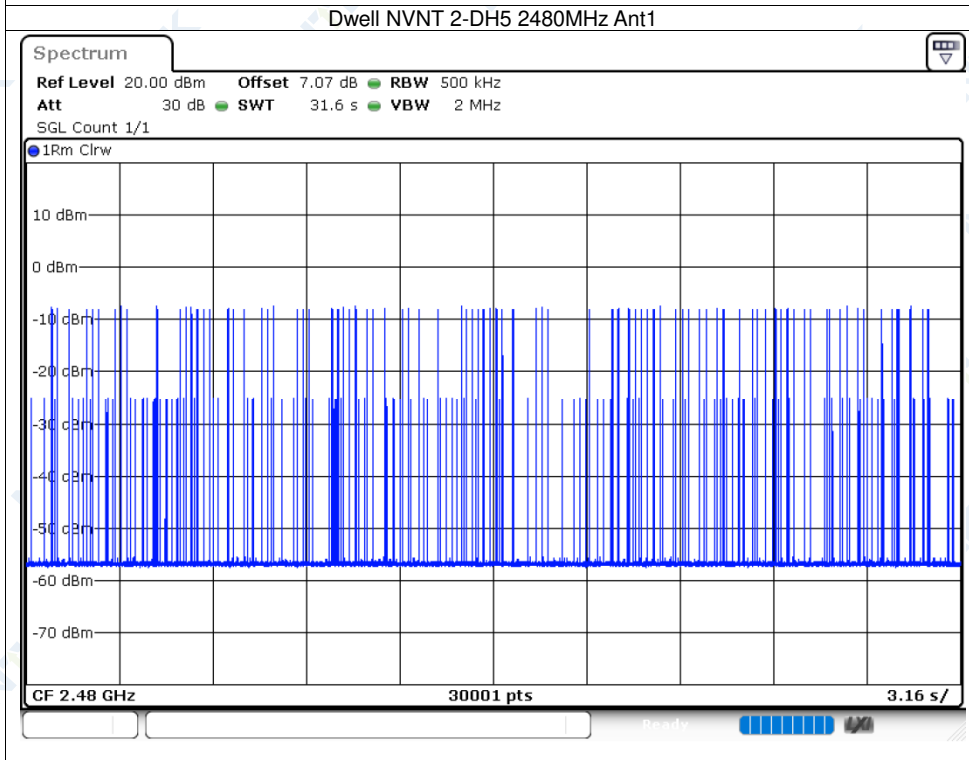
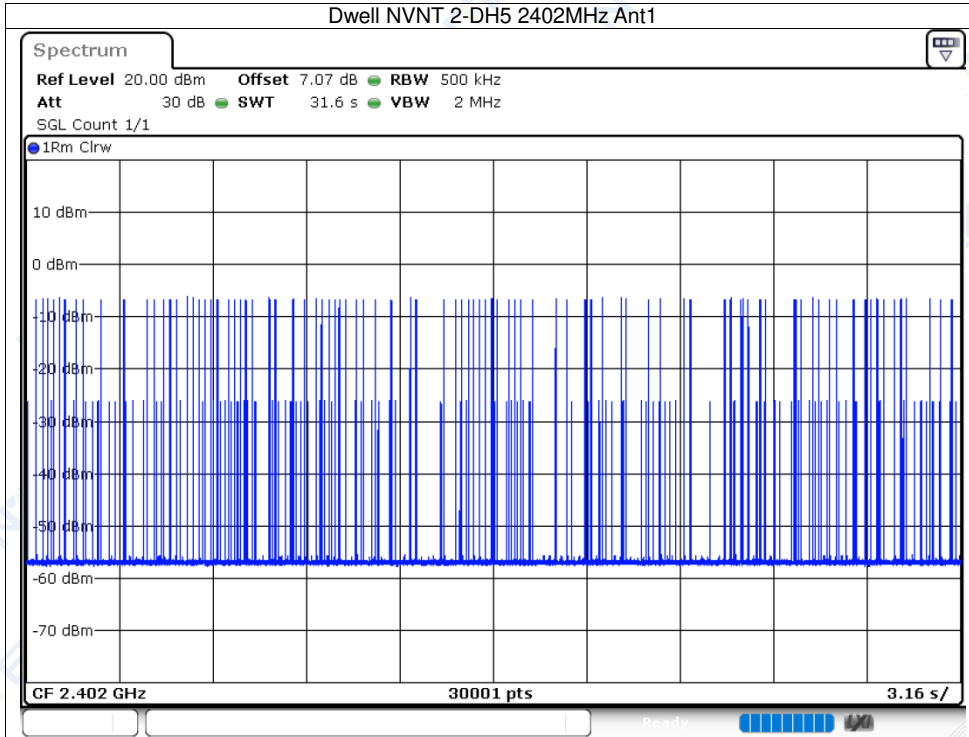

11.2 Frequency Occupation

Condition	Mode	Frequency (MHz)	Antenna	Burst Number	Limit	Sweep Time (ms)	Verdict
NVNT	1-DH1	2402	Ant1	2	1	121.028	Pass
NVNT	1-DH1	2480	Ant1	2	1	120.712	Pass
NVNT	1-DH3	2402	Ant1	2	1	517.924	Pass
NVNT	1-DH3	2480	Ant1	4	1	517.608	Pass
NVNT	1-DH5	2402	Ant1	6	1	912.292	Pass
NVNT	1-DH5	2480	Ant1	3	1	911.976	Pass
NVNT	2-DH1	2402	Ant1	2	1	123.24	Pass
NVNT	2-DH1	2480	Ant1	1	1	123.556	Pass
NVNT	2-DH3	2402	Ant1	3	1	517.608	Pass
NVNT	2-DH3	2480	Ant1	4	1	519.504	Pass
NVNT	2-DH5	2402	Ant1	3	1	911.66	Pass
NVNT	2-DH5	2480	Ant1	3	1	913.872	Pass

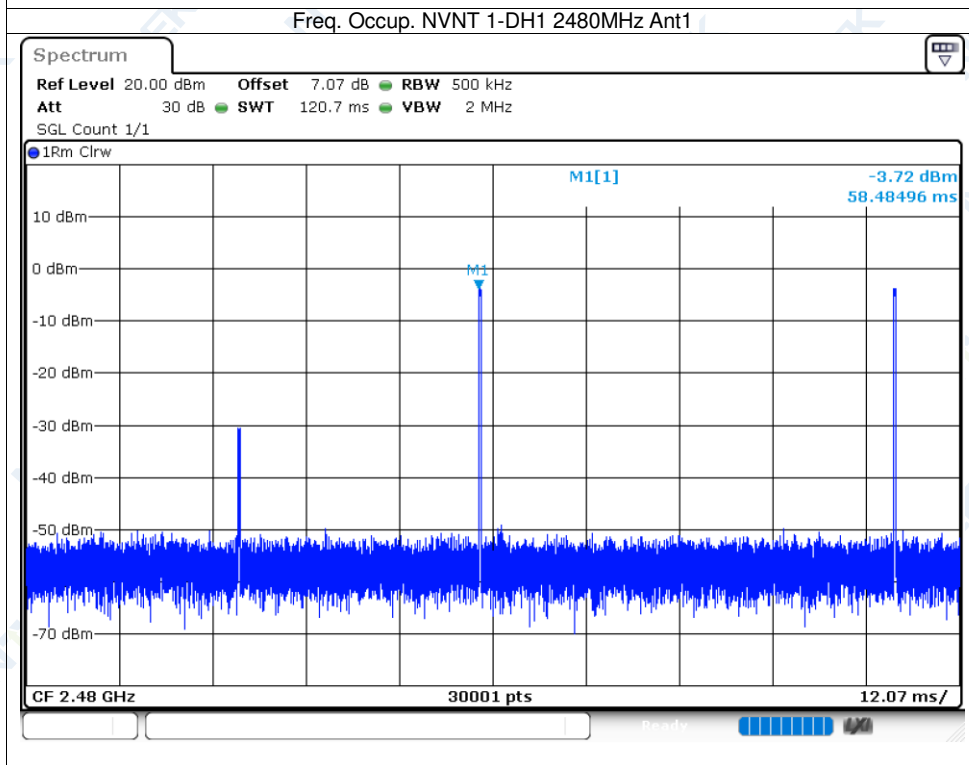
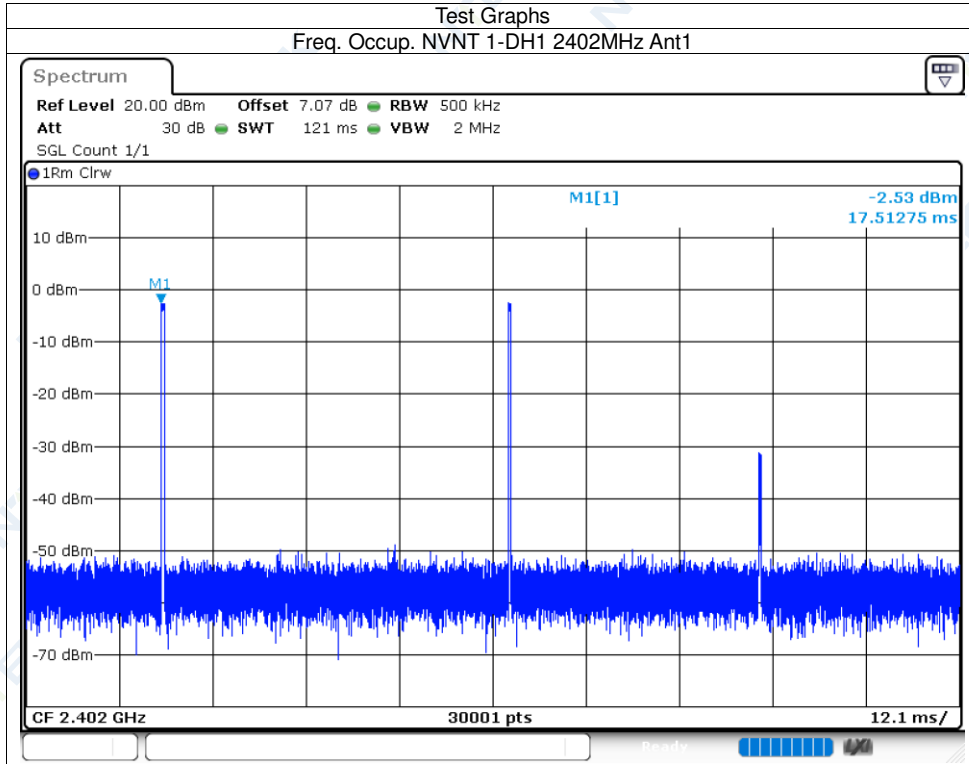

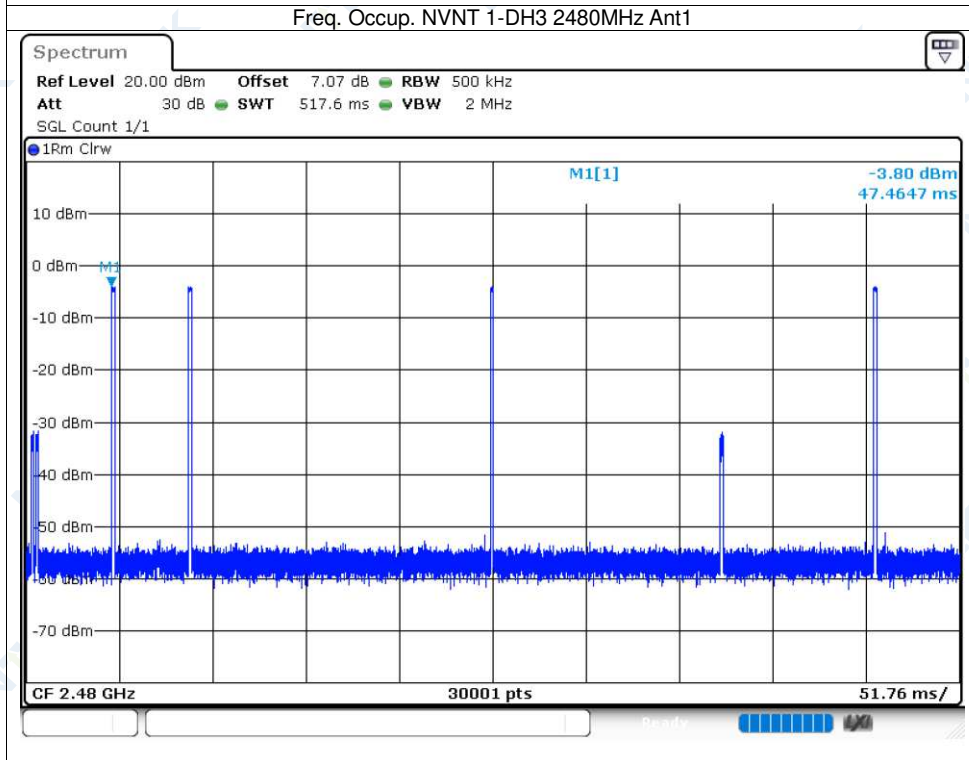
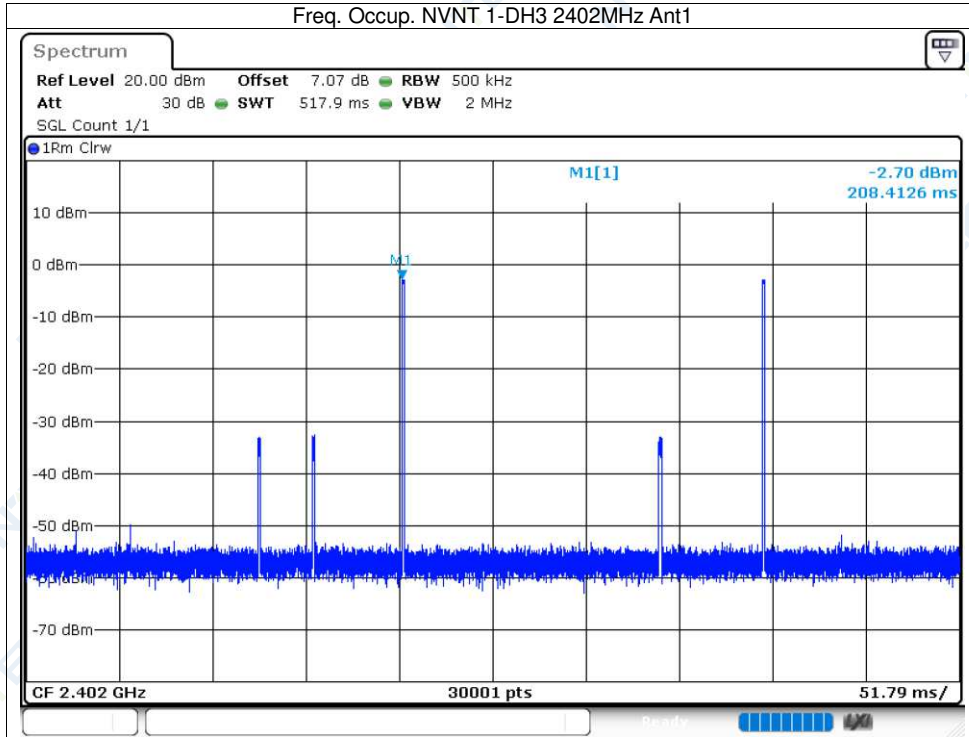

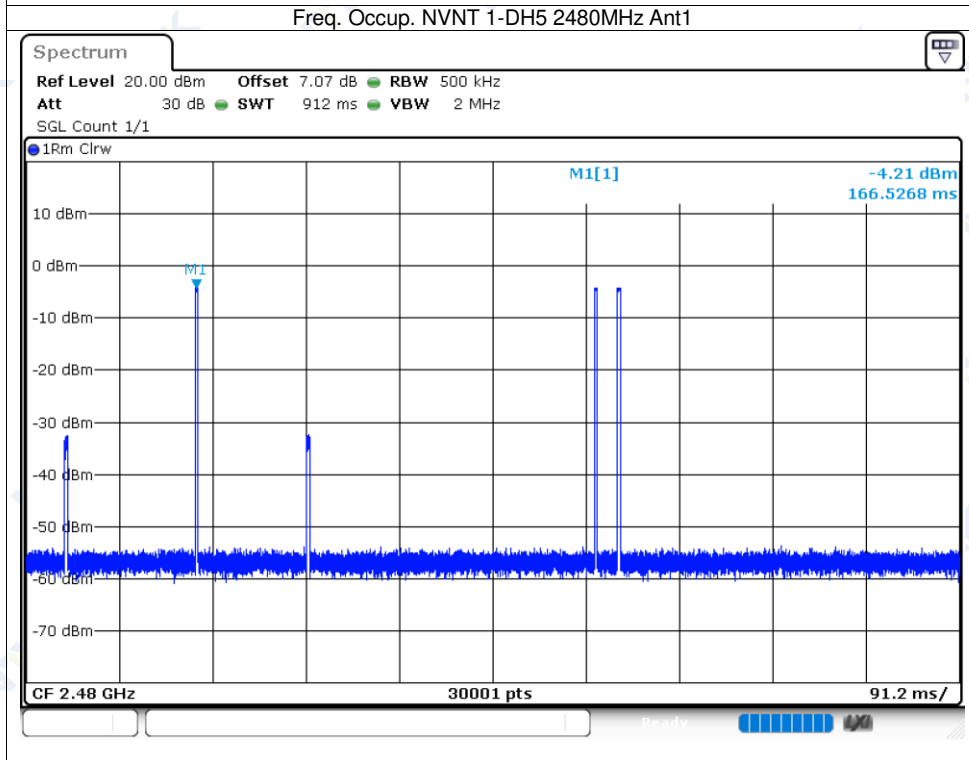
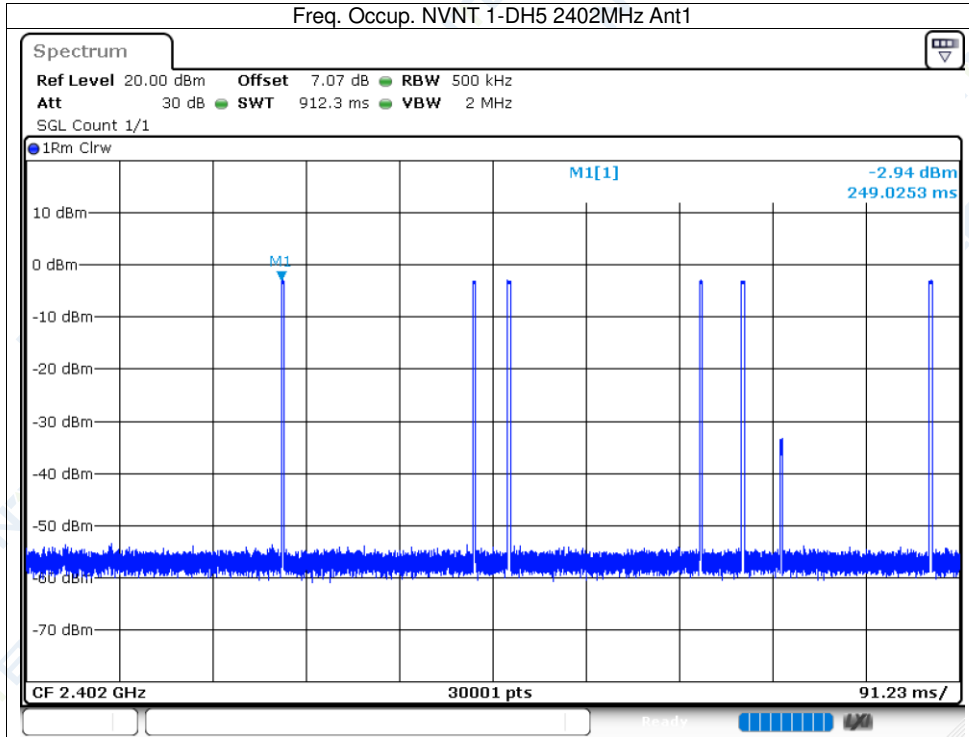

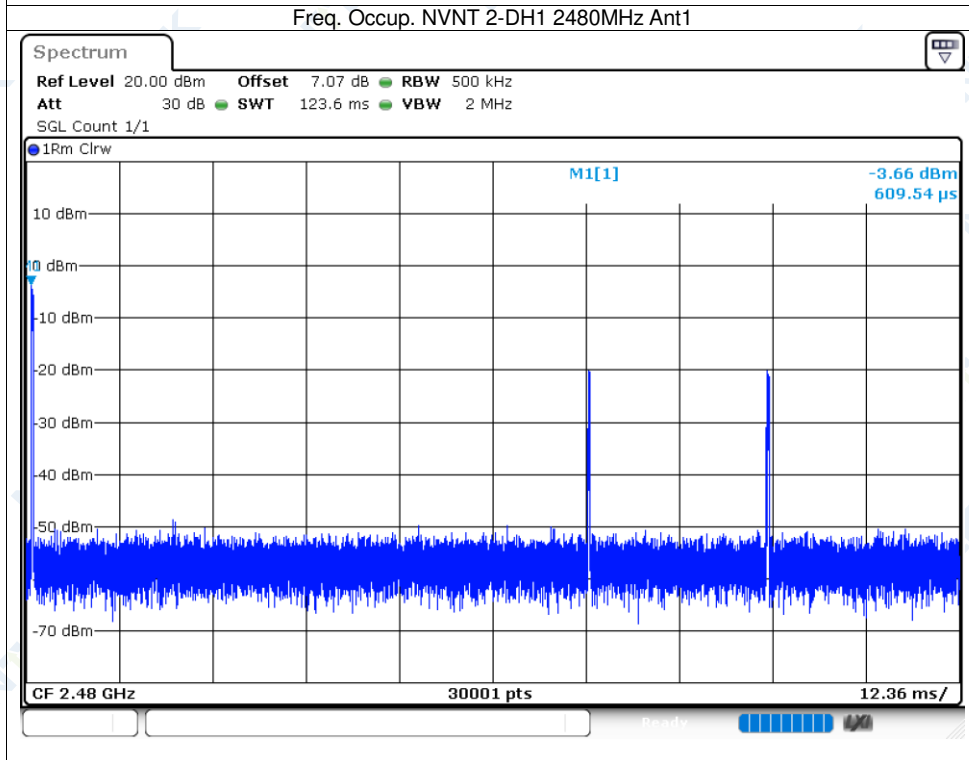
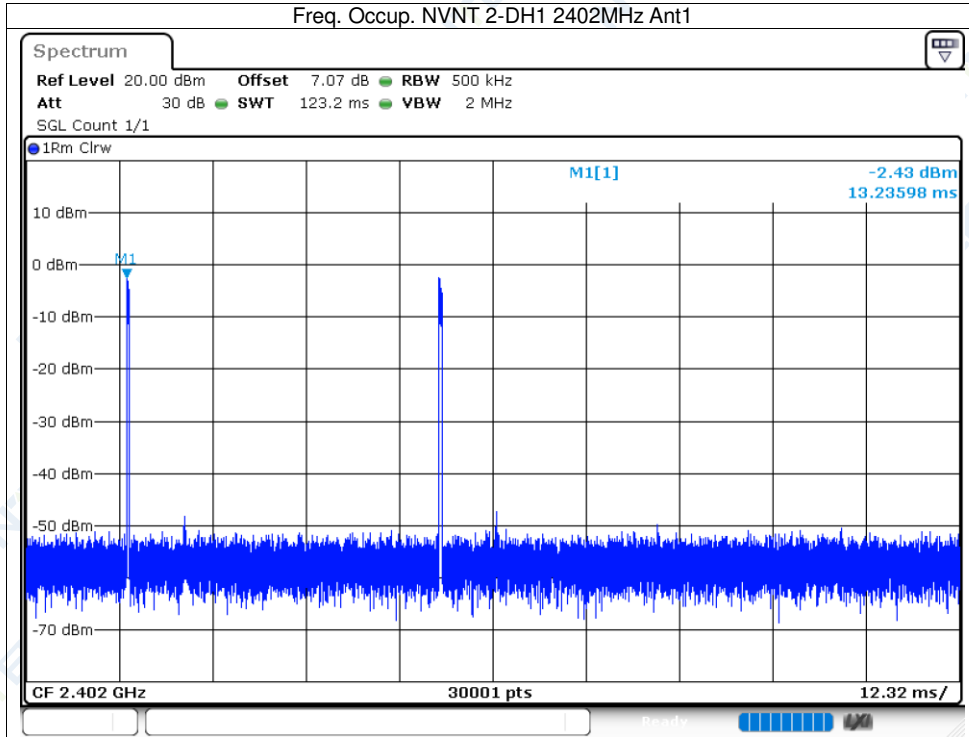

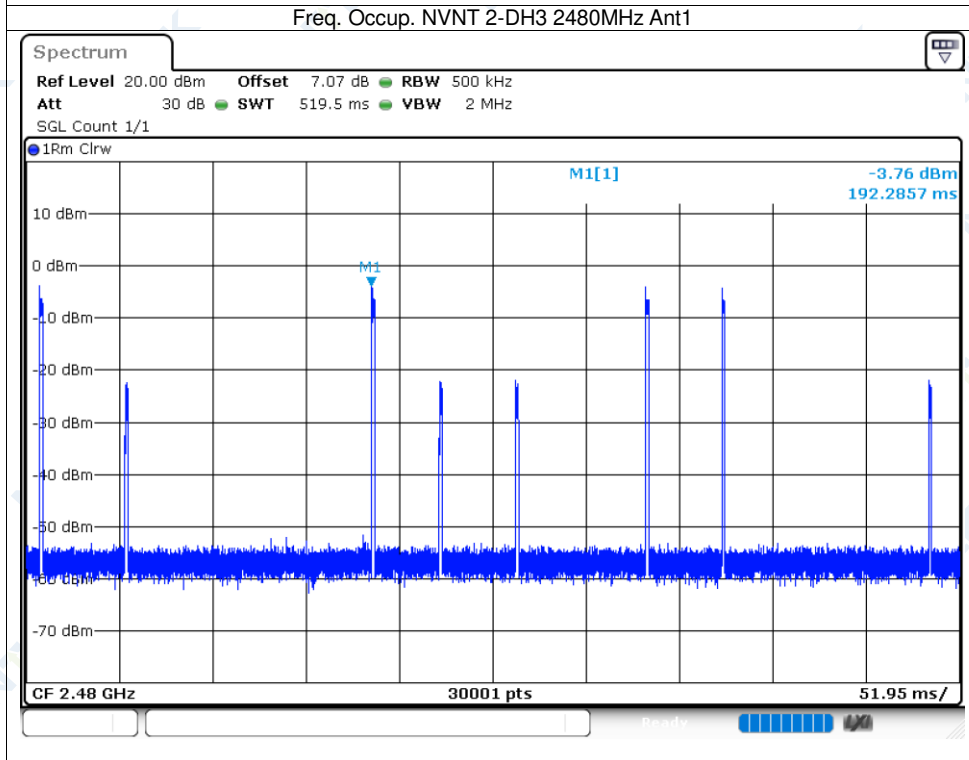
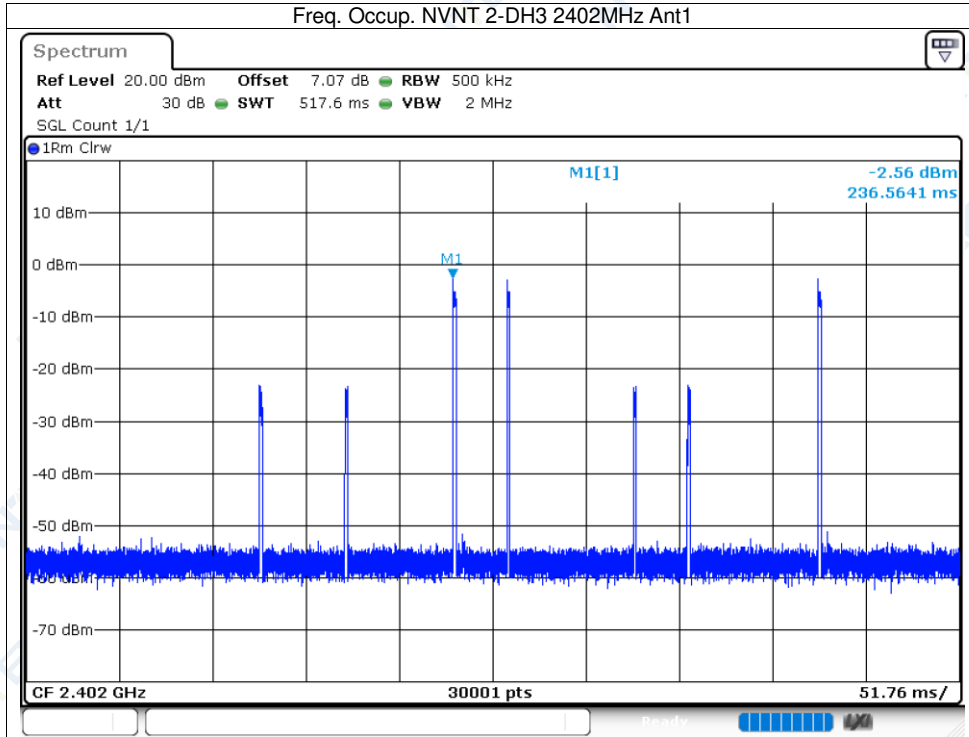

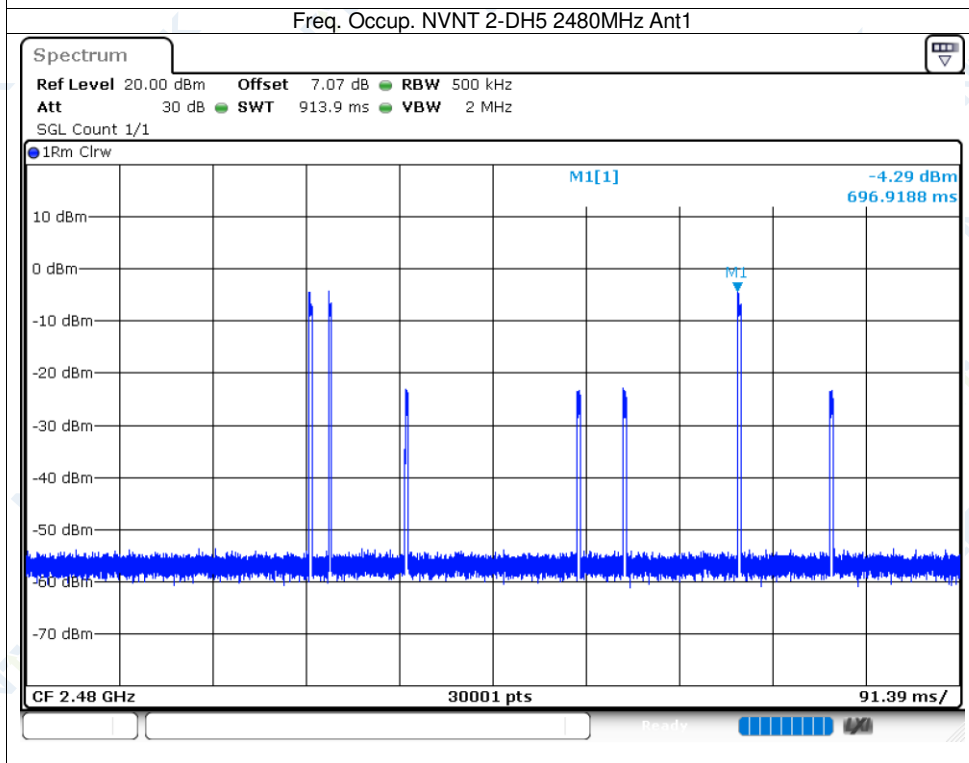
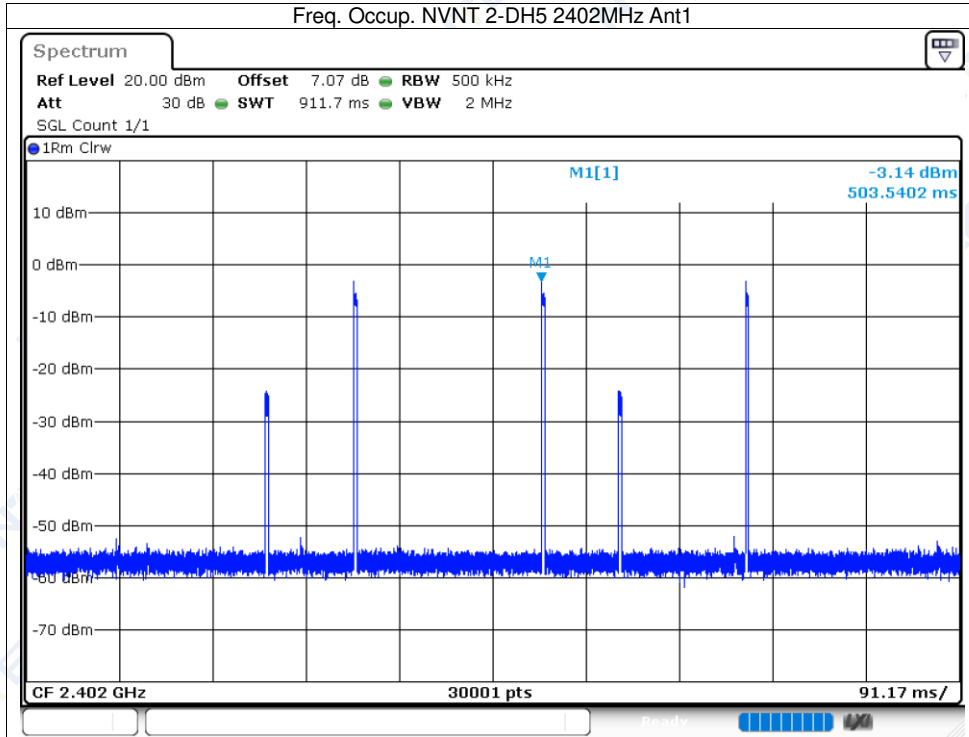

11.3 Dwell Time One Burst

Condition	Mode	Frequency (MHz)	Antenna	Pulse Time (ms)
NVNT	1-DH1	2402	Ant1	0.383
NVNT	1-DH1	2480	Ant1	0.382
NVNT	1-DH3	2402	Ant1	1.639
NVNT	1-DH3	2480	Ant1	1.638
NVNT	1-DH5	2402	Ant1	2.887
NVNT	1-DH5	2480	Ant1	2.886
NVNT	2-DH1	2402	Ant1	0.39
NVNT	2-DH1	2480	Ant1	0.391
NVNT	2-DH3	2402	Ant1	1.638
NVNT	2-DH3	2480	Ant1	1.644
NVNT	2-DH5	2402	Ant1	2.885
NVNT	2-DH5	2480	Ant1	2.892

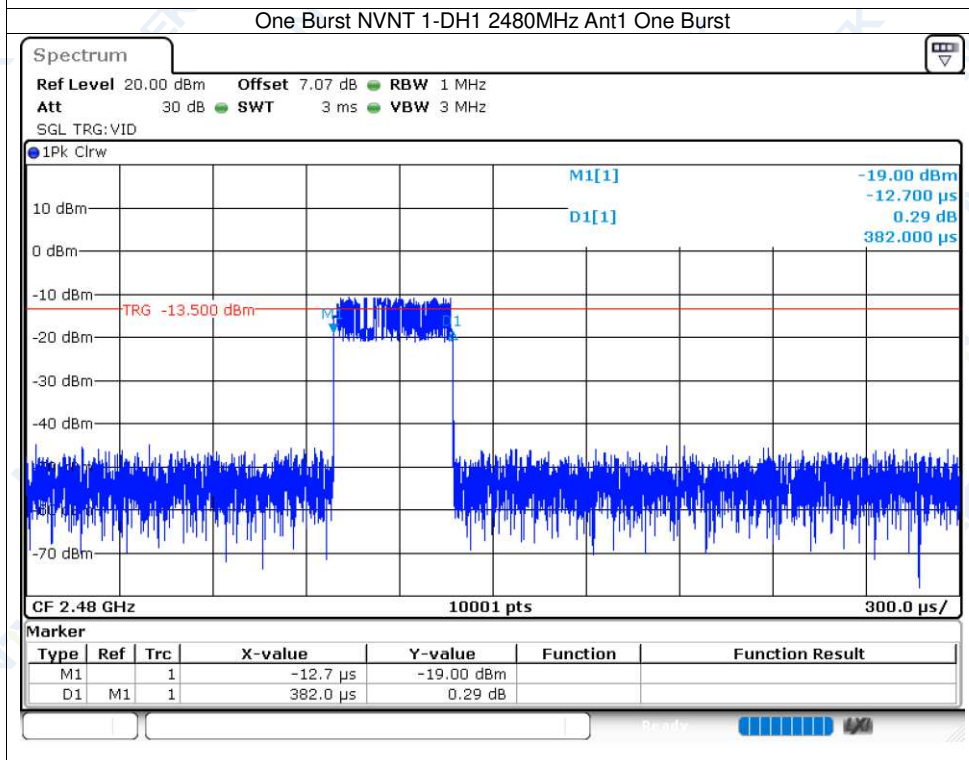
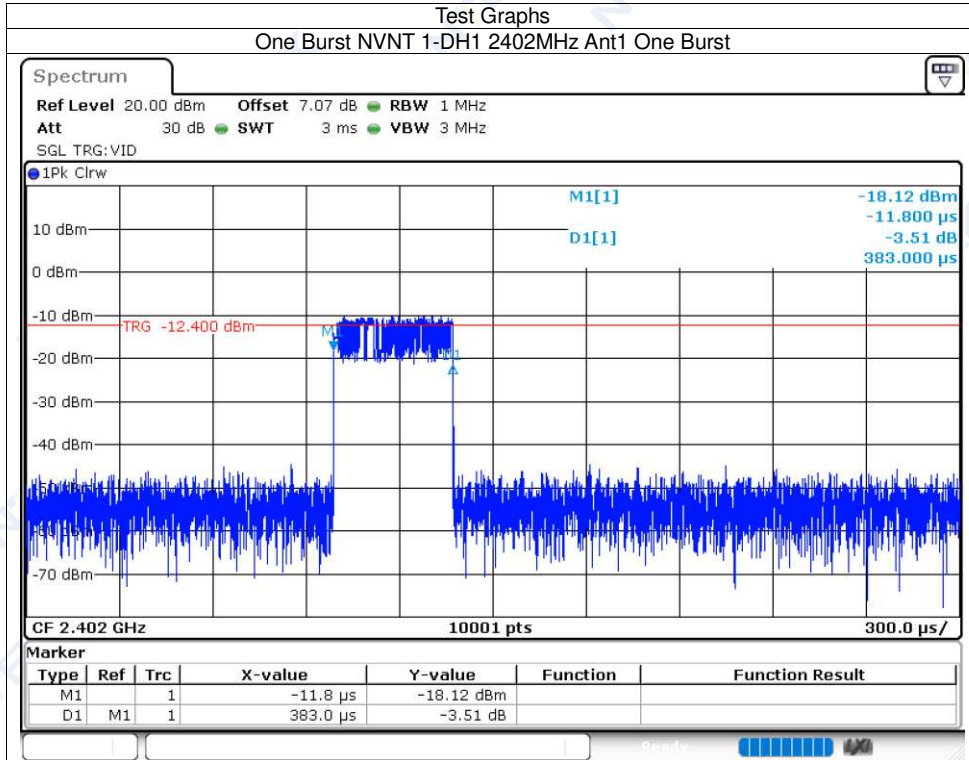

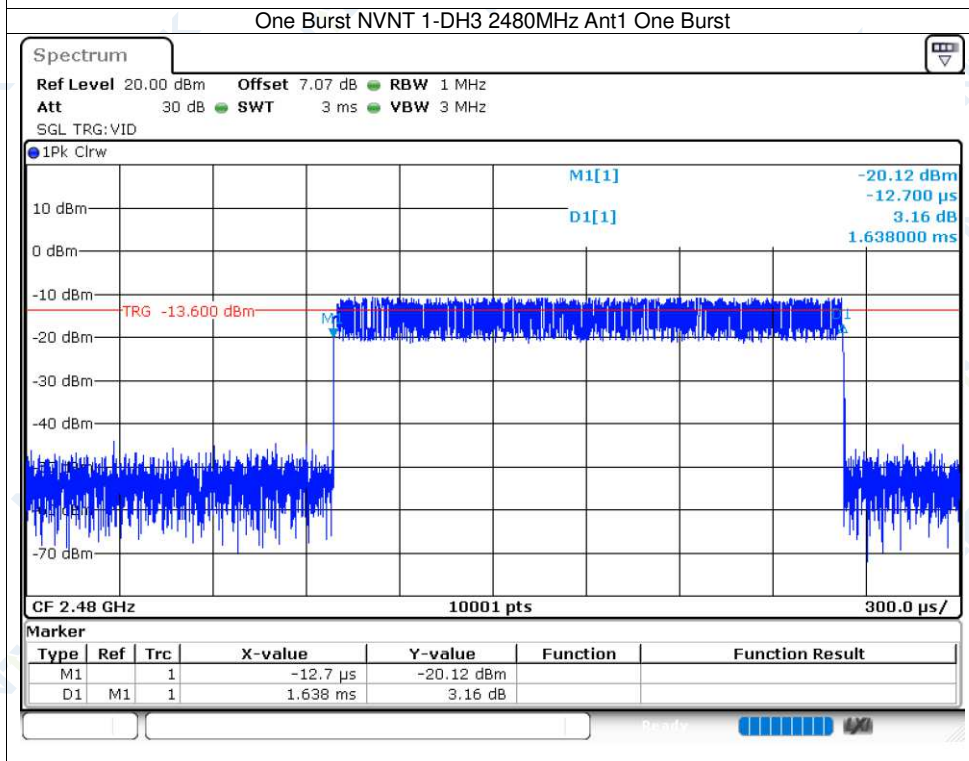
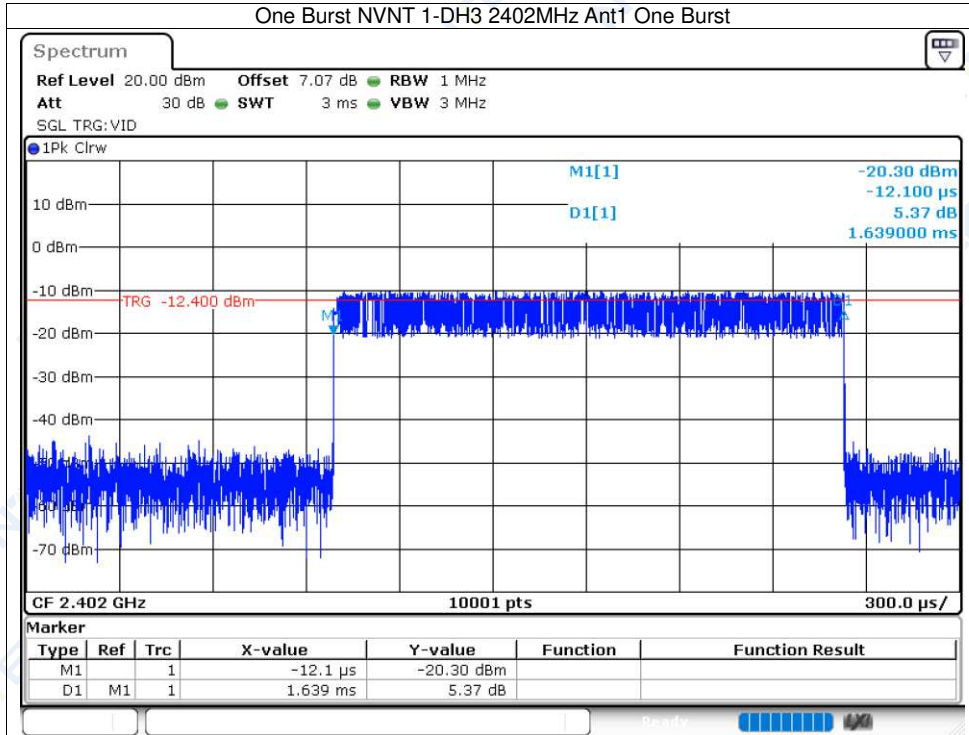

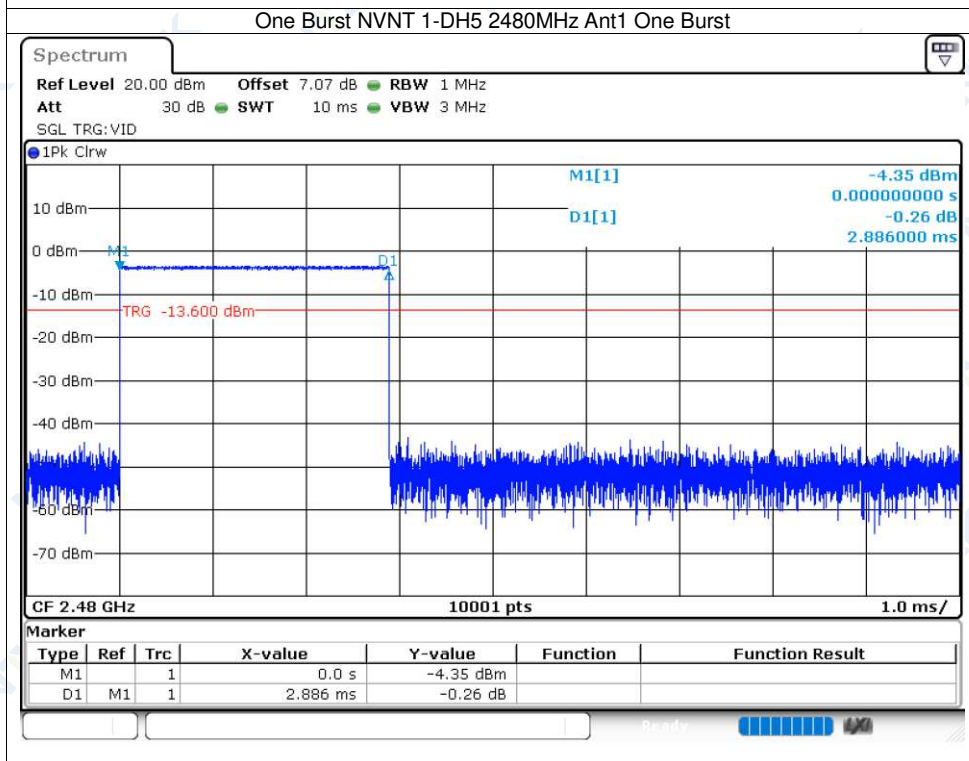
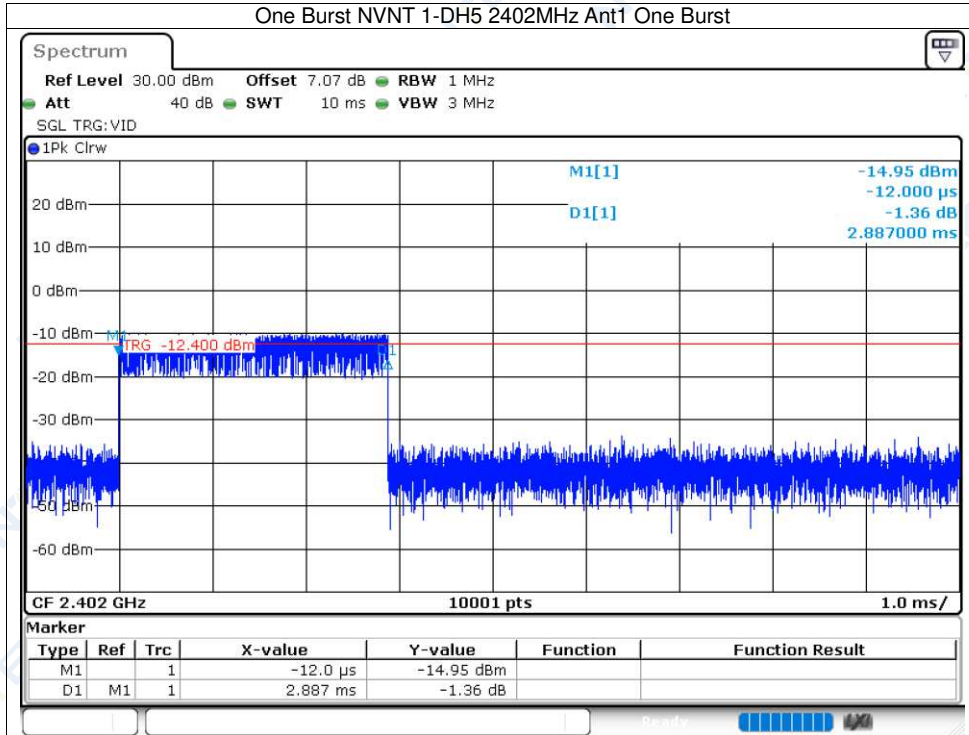

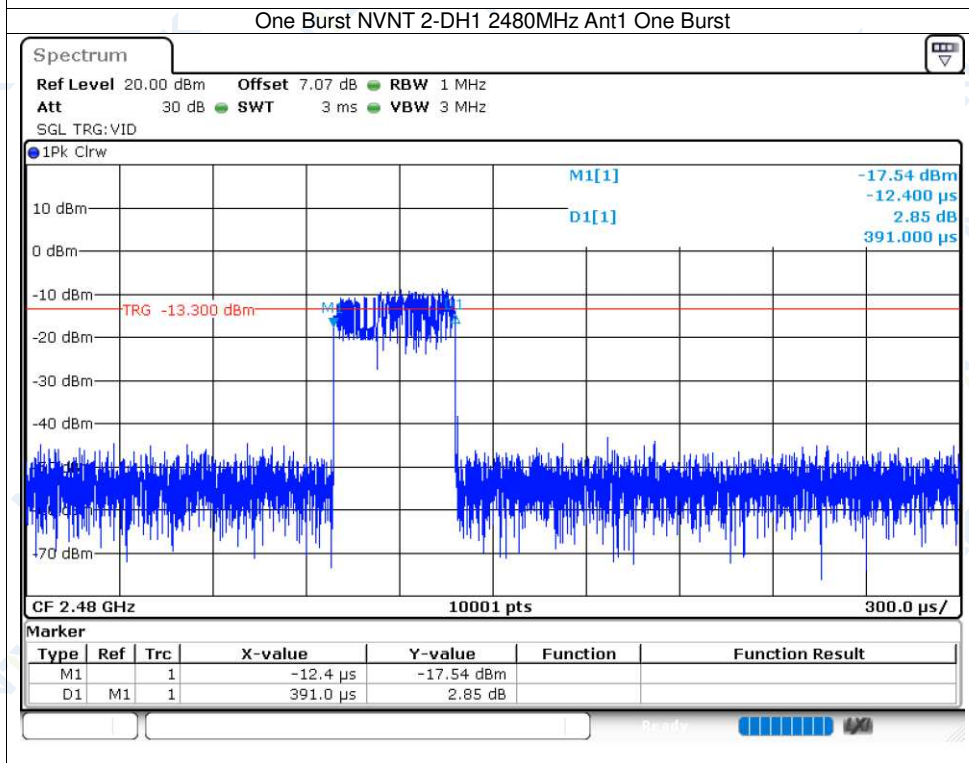
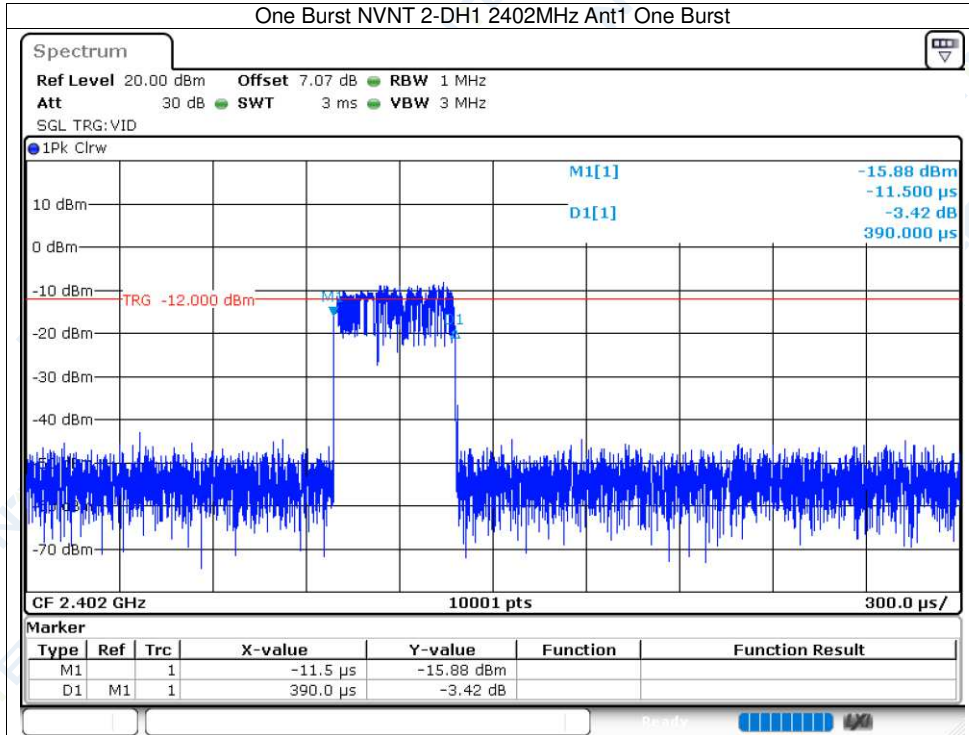

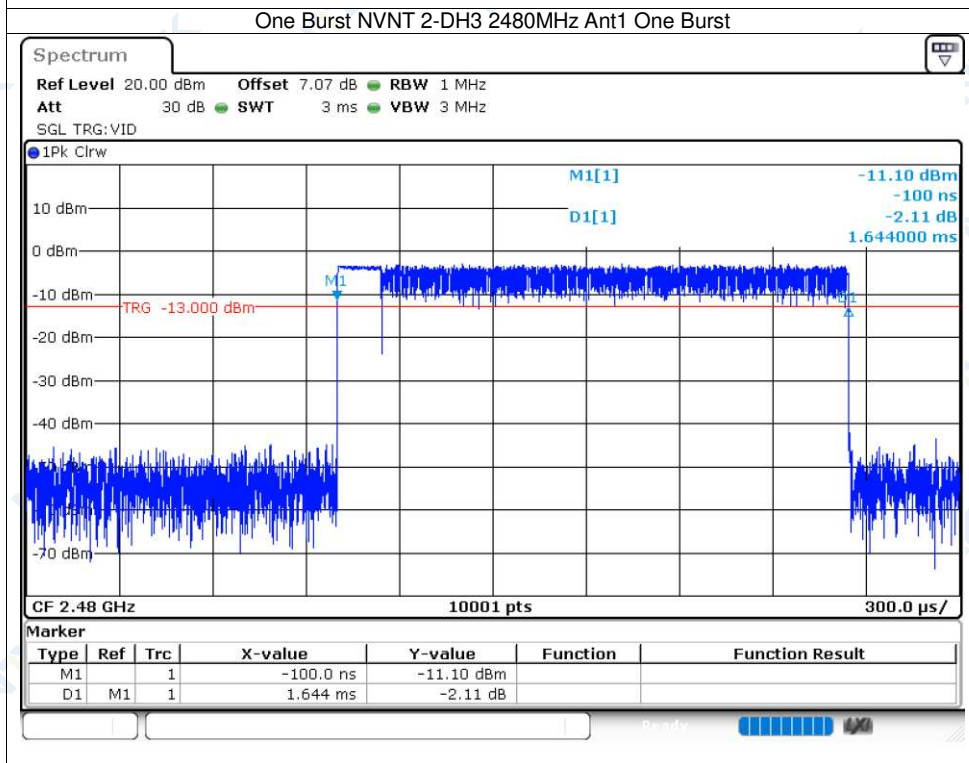
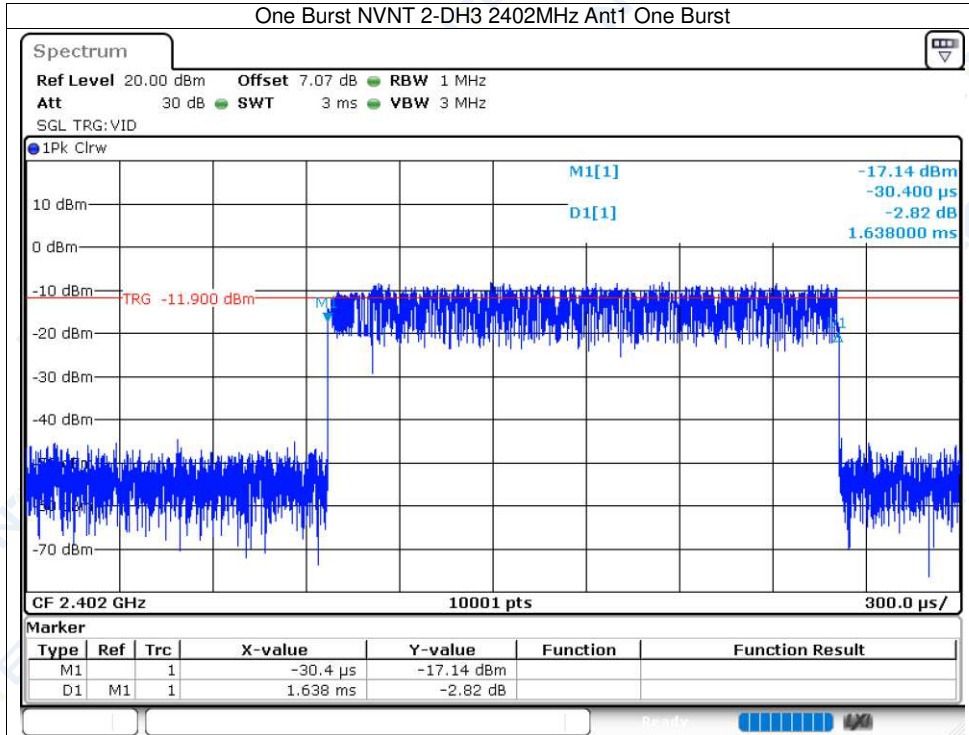

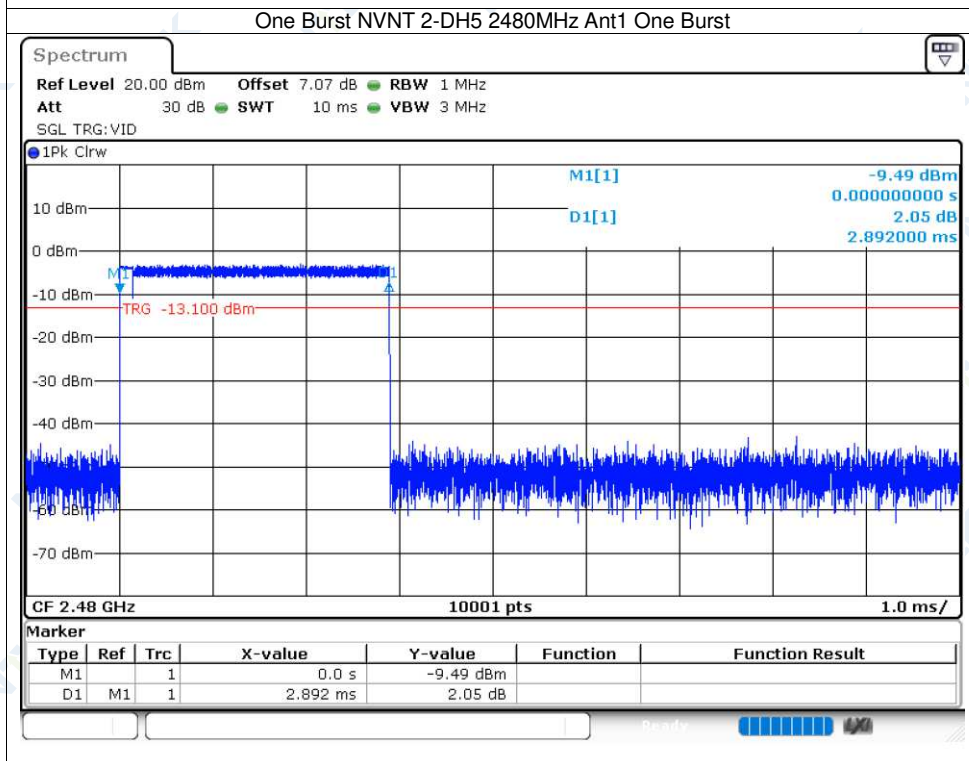
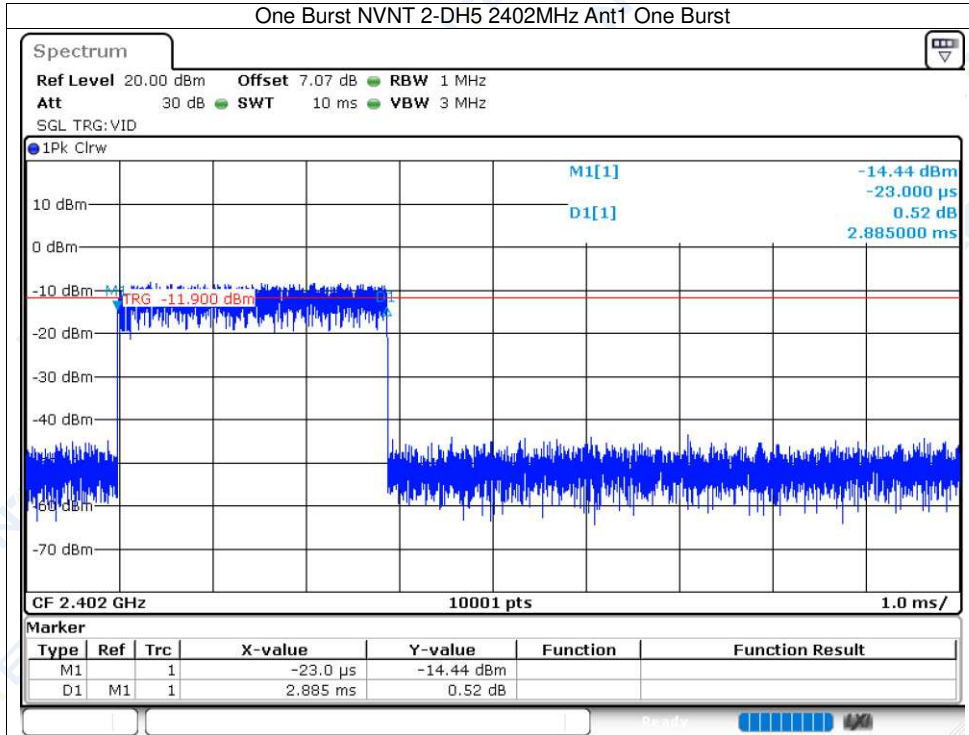

11.4 RF Output Power

Condition	Mode	Frequency (MHz)	Antenna	Max Burst RMS Power (dBm)	Burst Number	Max EIRP (dBm)	Limit (dBm)	Verdict
NVNT	1-DH5	hopping	Ant1	-3.32	28	-1.57	20	Pass
NVNT	2-DH5	hopping	Ant1	-3.39	55	-1.64	20	Pass
NVLT	1-DH5	hopping	Ant1	-4	28	-2.25	20	Pass
NVLT	2-DH5	hopping	Ant1	-3.98	55	-2.23	20	Pass
NVHT	1-DH5	hopping	Ant1	-4.03	28	-2.28	20	Pass
NVHT	2-DH5	hopping	Ant1	-4.08	55	-2.33	20	Pass

Test Graphs
Power NVNT 1-DH5 2402MHz Ant1

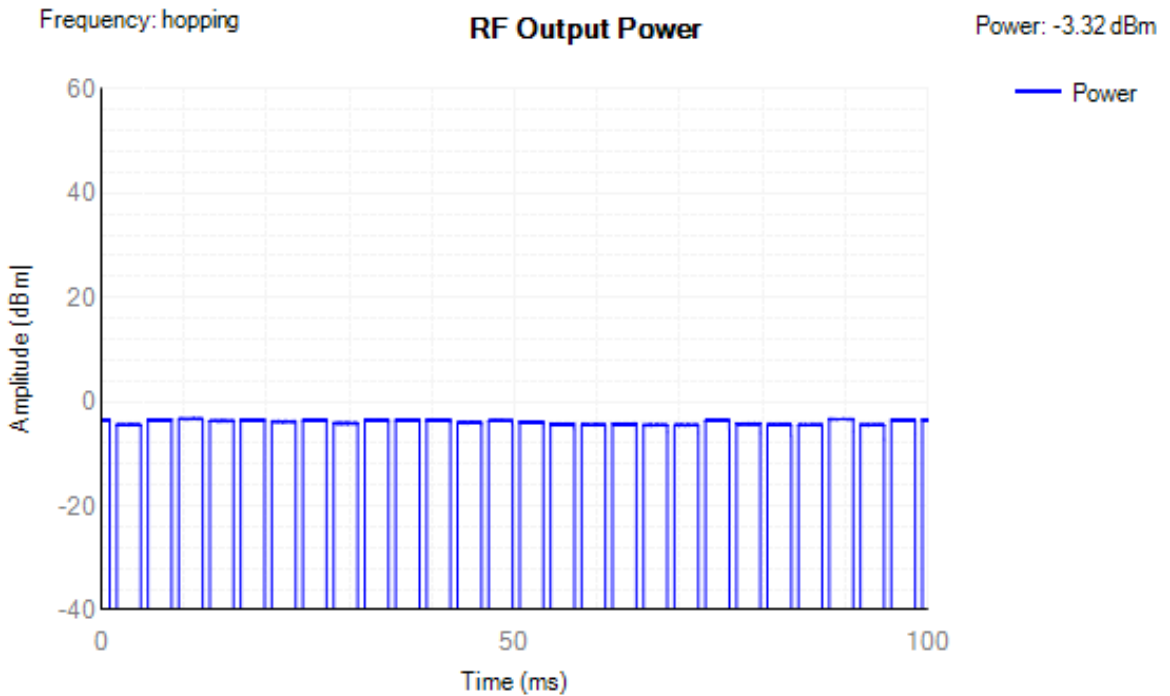

Power NVNT 2-DH5 2402MHz Ant1

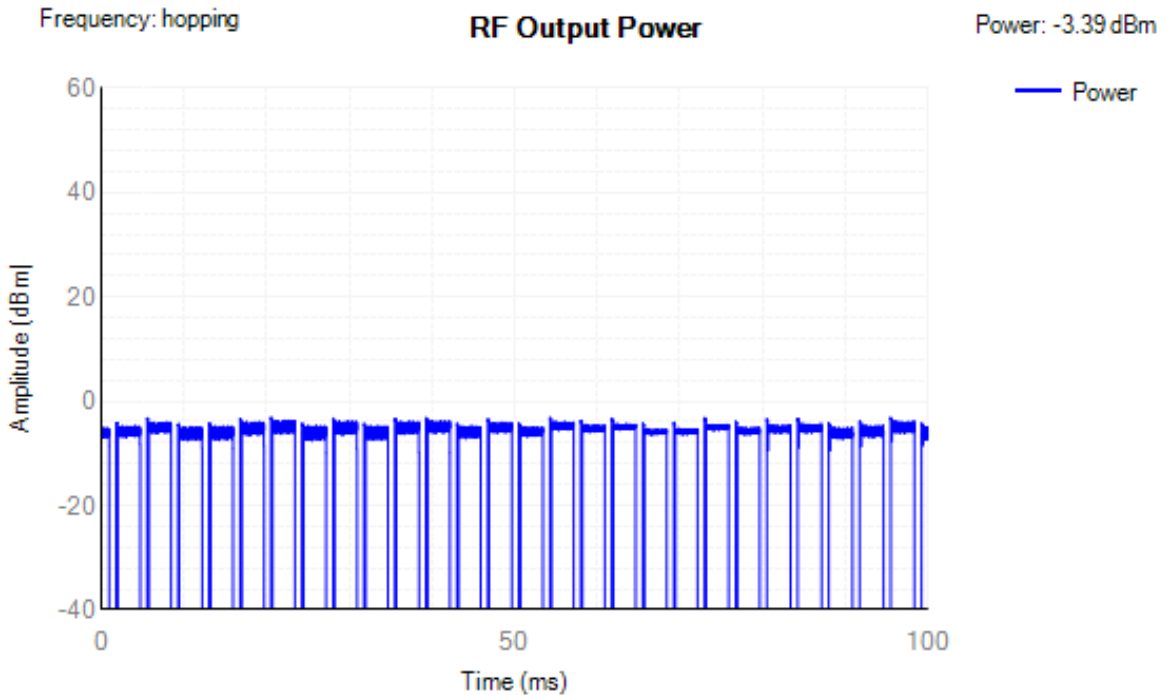

11.5 Hopping Frequency Separation

Condition	Mode	Antenna	Hopping Freq1 (MHz)	Hopping Freq2 (MHz)	HFS (MHz)	Limit (MHz)	Verdict
NVNT	1-DH5	Ant1	2402.031	2403.033	1.002	0.1	Pass
NVNT	1-DH5	Ant1	2441.031	2442.018	0.987	0.1	Pass
NVNT	1-DH5	Ant1	2479.035	2480.035	1	0.1	Pass
NVNT	2-DH5	Ant1	2402.016	2403.018	1.002	0.1	Pass
NVNT	2-DH5	Ant1	2441.02	2442.02	1	0.1	Pass
NVNT	2-DH5	Ant1	2478.854	2480.02	1.166	0.1	Pass

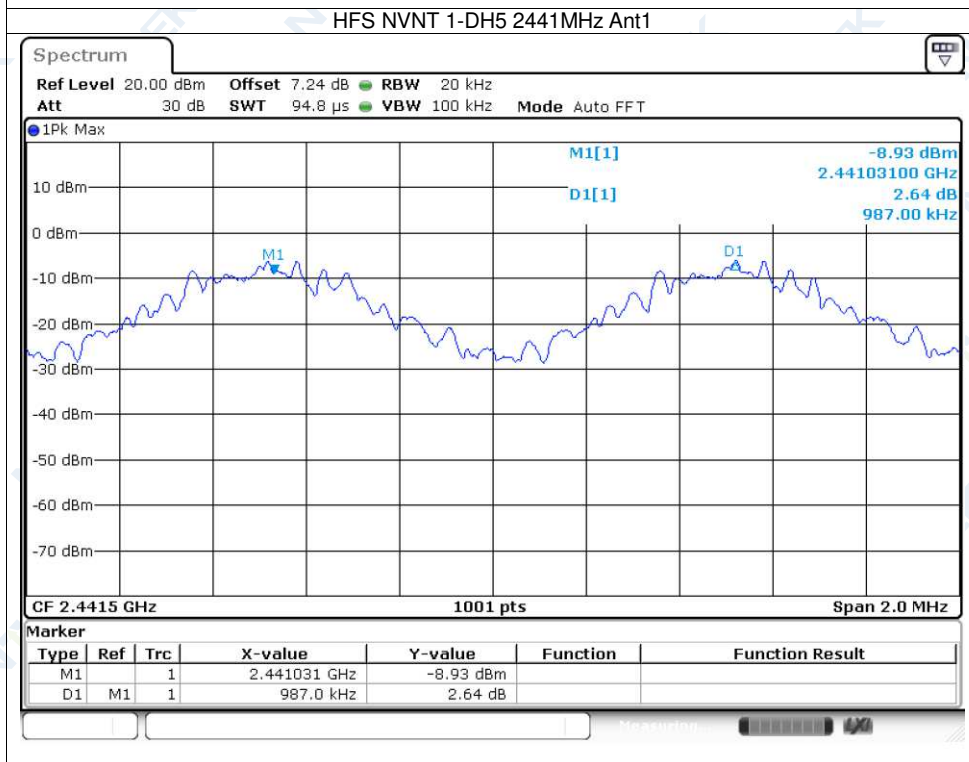
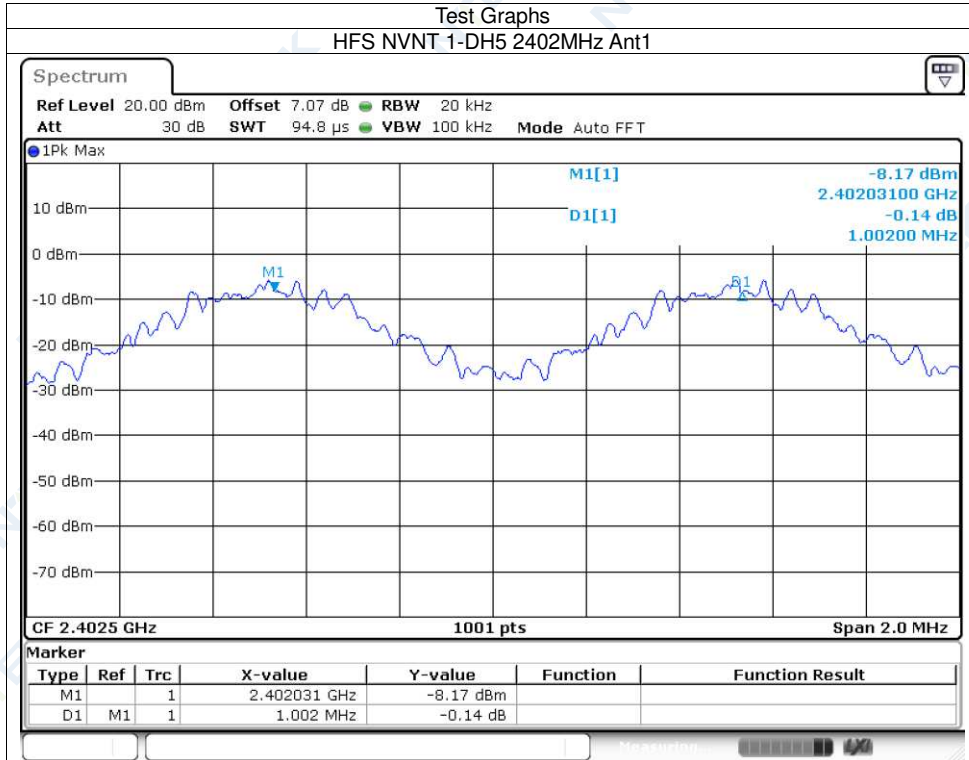

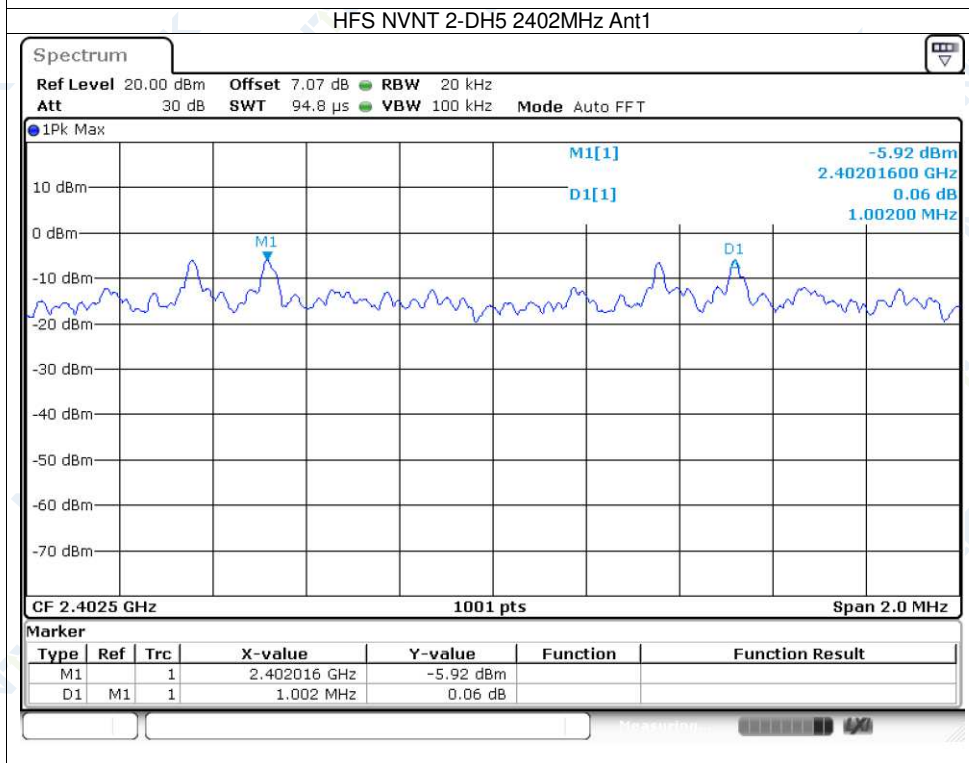
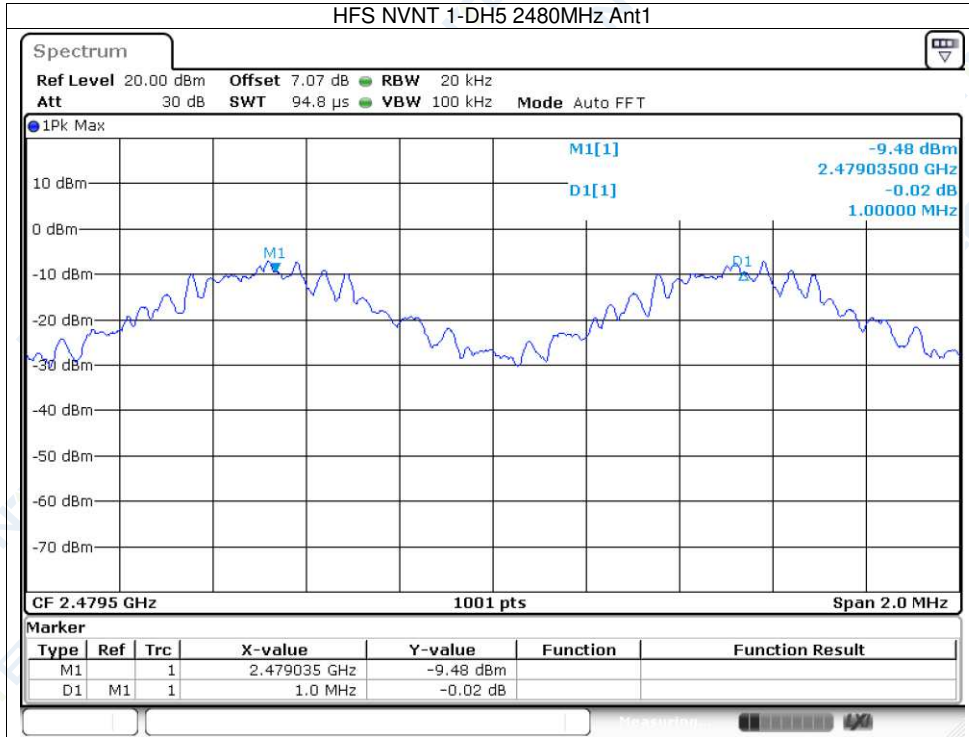

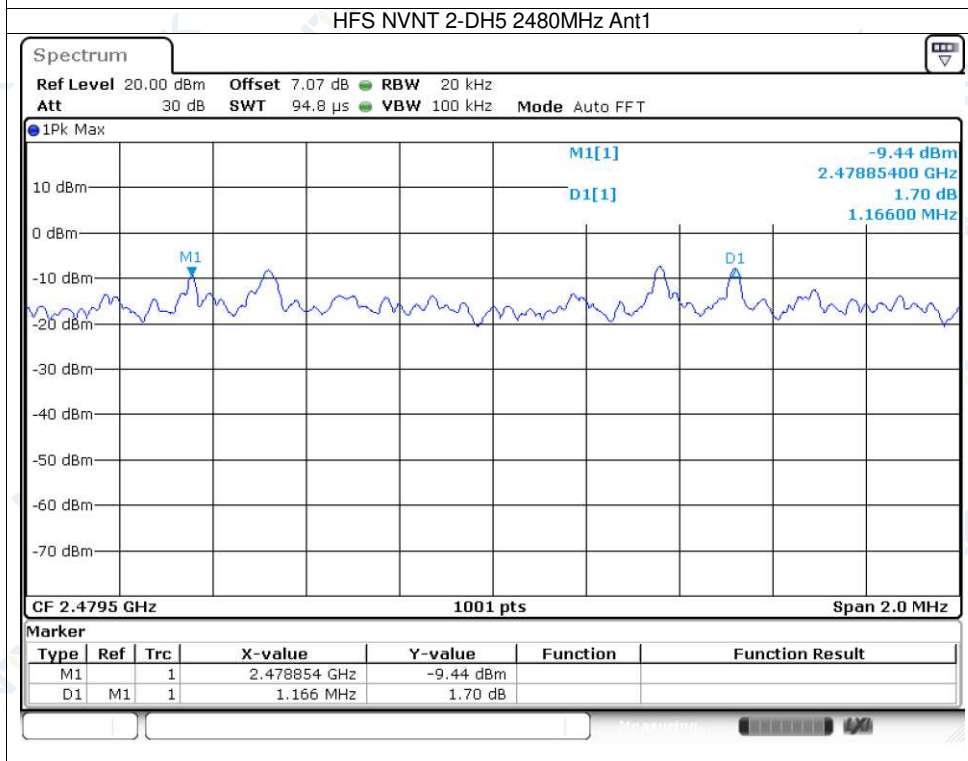
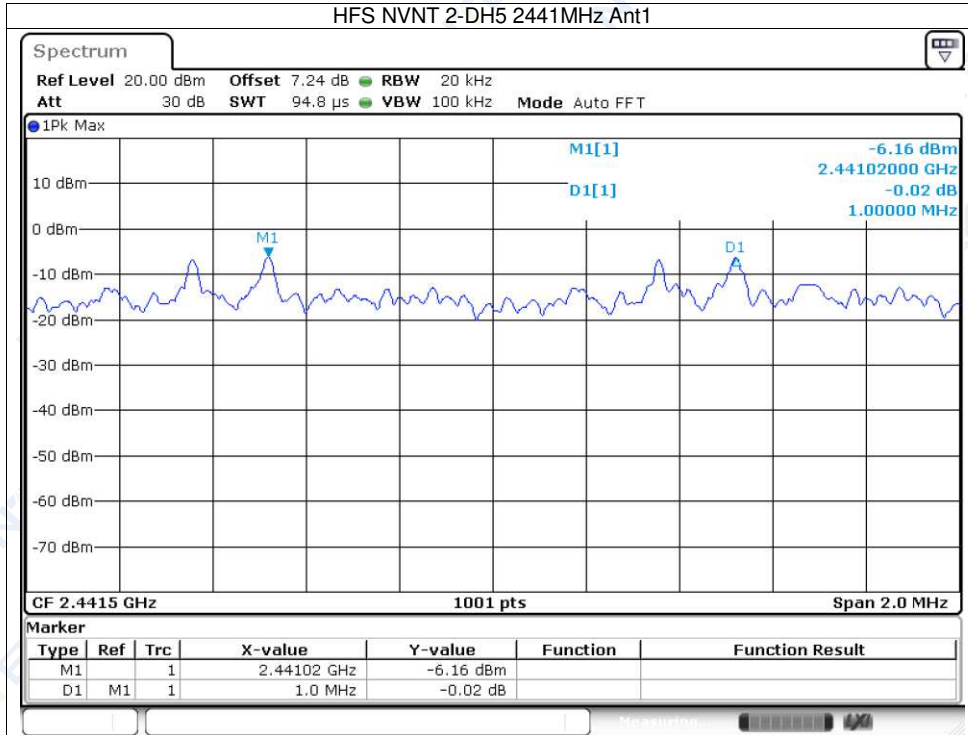

11.6 Occupied Channel Bandwidth

Condition	Mode	Frequency (MHz)	Antenna	Center Frequency (MHz)	OBW (MHz)	Lower Edge (MHz)	Upper Edge (MHz)	Limit OBW (MHz)	Verdict
NVNT	1-DH5	2402	Ant1	2402.02	0.885	2401.577	2402.463	2400 - 2483.5MHz	Pass
NVNT	1-DH5	2480	Ant1	2480.022	0.897	2479.573	2480.47	2400 - 2483.5MHz	Pass
NVNT	2-DH5	2402	Ant1	2402.02	1.194	2401.423	2402.617	2400 - 2483.5MHz	Pass
NVNT	2-DH5	2480	Ant1	2480.02	1.185	2479.427	2480.612	2400 - 2483.5MHz	Pass

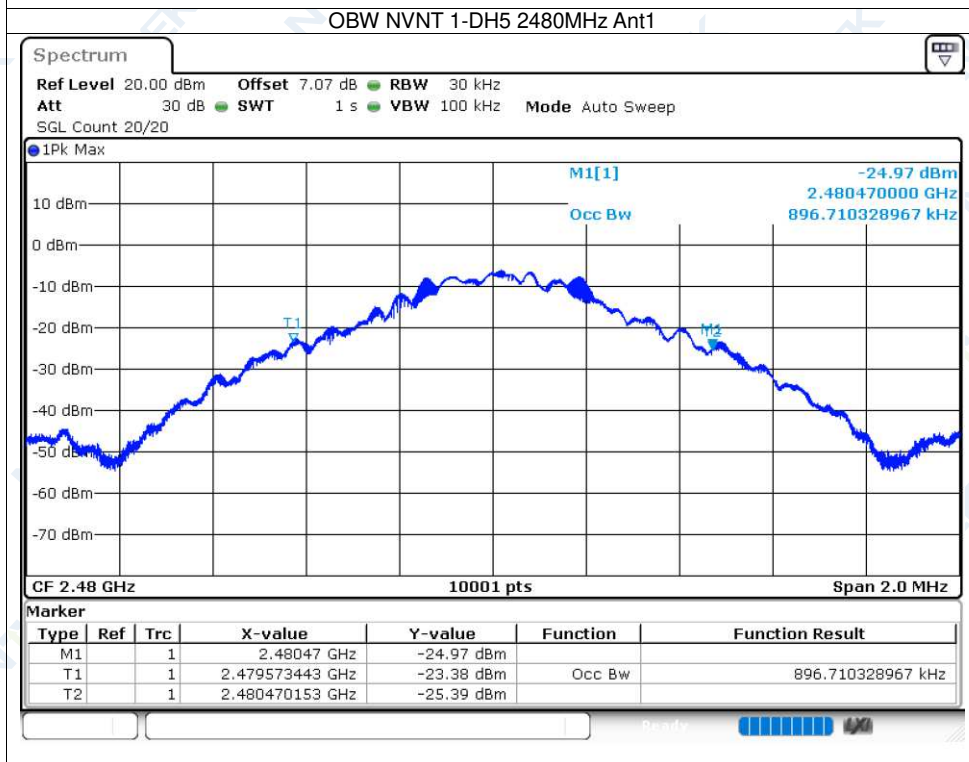
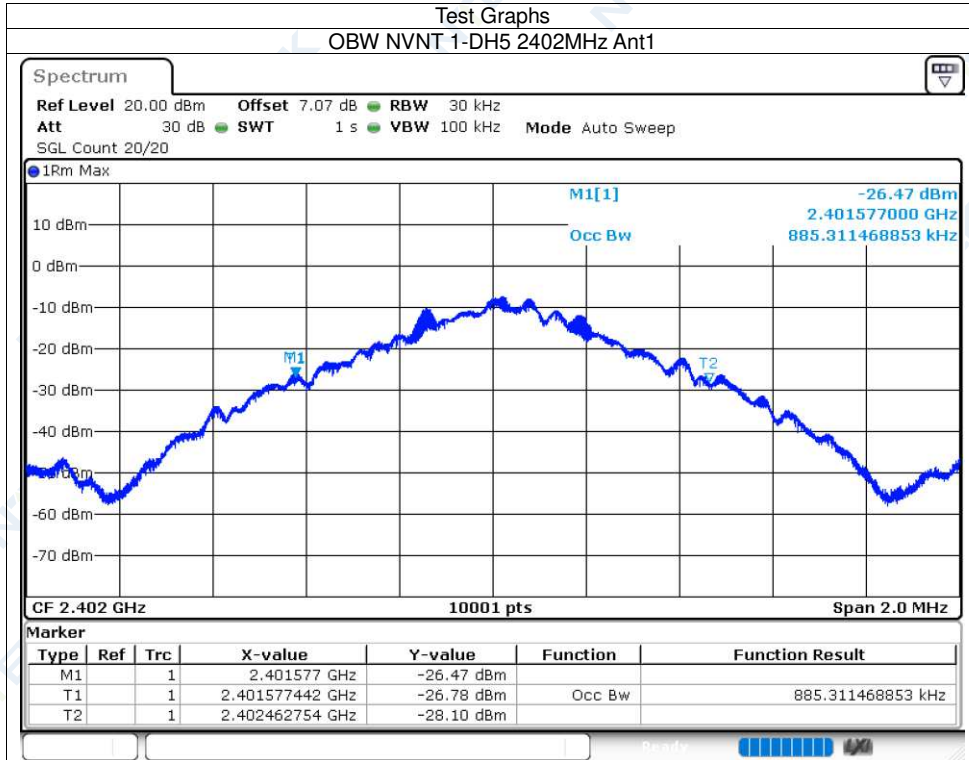

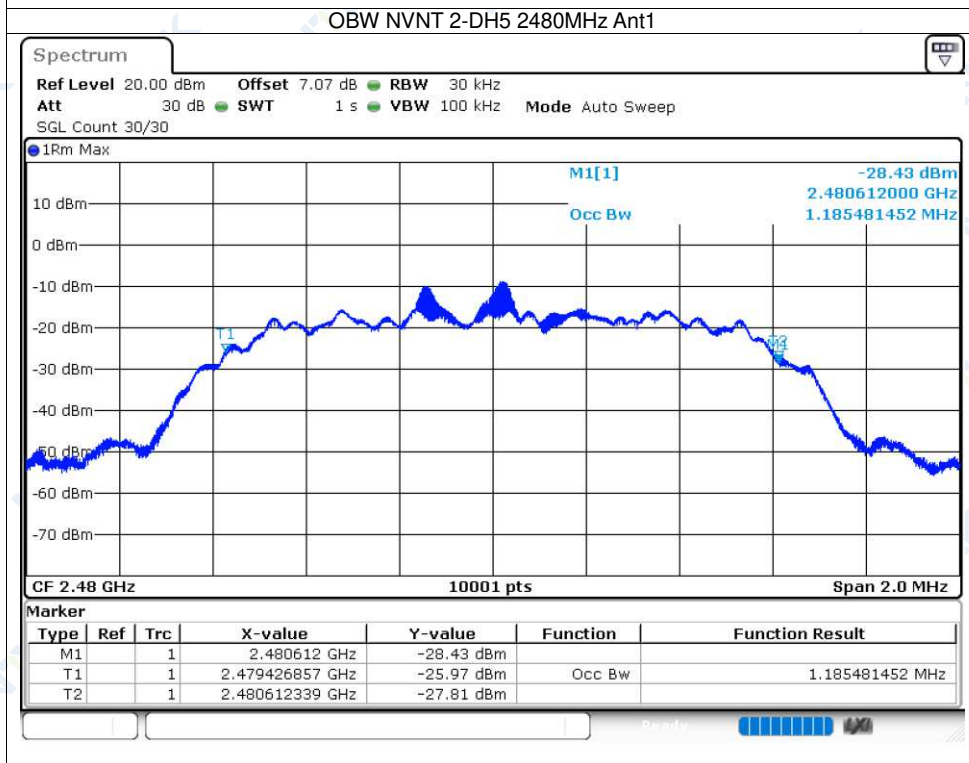
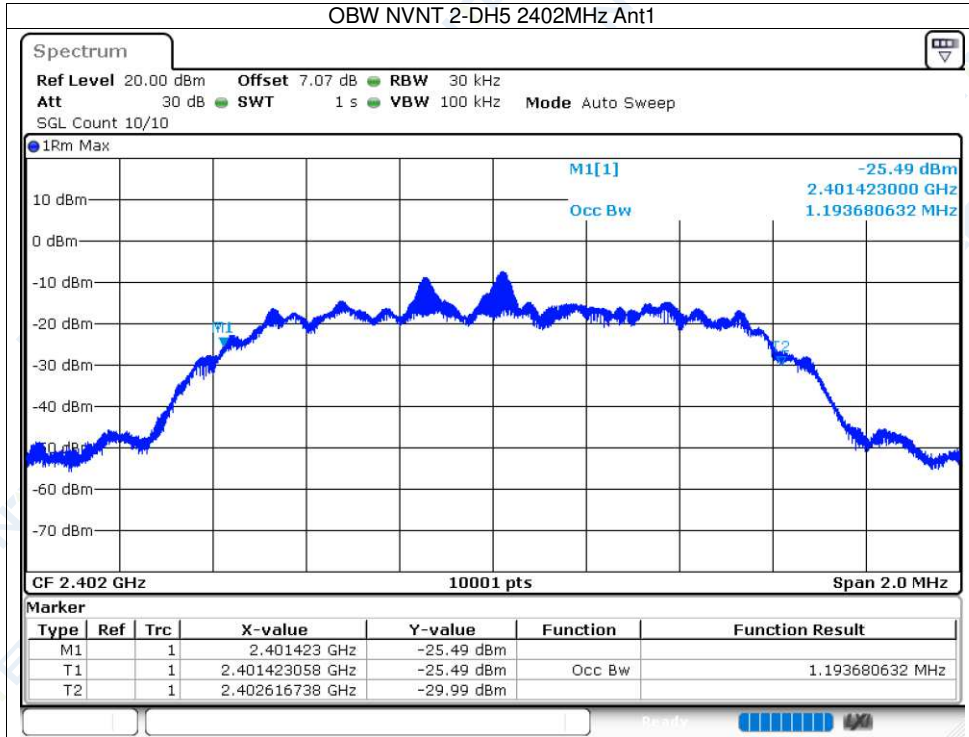

11.7 Transmitter unwanted emissions in the out-of-band domain

Condition	Mode	Frequency (MHz)	Antenna	OOB Frequency (MHz)	Level (dBm/MHz)	Limit (dBm/MHz)	Verdict
NVNT	1-DH5	Hopping	Ant1	2399.5	-46.52	-10	Pass
NVNT	1-DH5	Hopping	Ant1	2398.5	-45.99	-20	Pass
NVNT	1-DH5	Hopping	Ant1	2484	-45.82	-10	Pass
NVNT	1-DH5	Hopping	Ant1	2485	-45.86	-20	Pass
NVNT	1-DH5	Hopping	Ant1	2399.5	-46.53	-10	Pass
NVNT	1-DH5	Hopping	Ant1	2398.5	-46.01	-20	Pass
NVNT	1-DH5	Hopping	Ant1	2484	-45.83	-10	Pass
NVNT	1-DH5	Hopping	Ant1	2485	-45.85	-20	Pass
NVNT	2-DH5	Hopping	Ant1	2399.5	-46.54	-10	Pass
NVNT	2-DH5	Hopping	Ant1	2398.5	-46.01	-20	Pass
NVNT	2-DH5	Hopping	Ant1	2484	-45.83	-10	Pass
NVNT	2-DH5	Hopping	Ant1	2485	-45.85	-20	Pass
NVNT	2-DH5	Hopping	Ant1	2399.5	-46.56	-10	Pass
NVNT	2-DH5	Hopping	Ant1	2485	-45.82	-20	Pass

Test Graphs
Tx. Emissions OOB NVNT 1-DH5 2402MHz Ant1

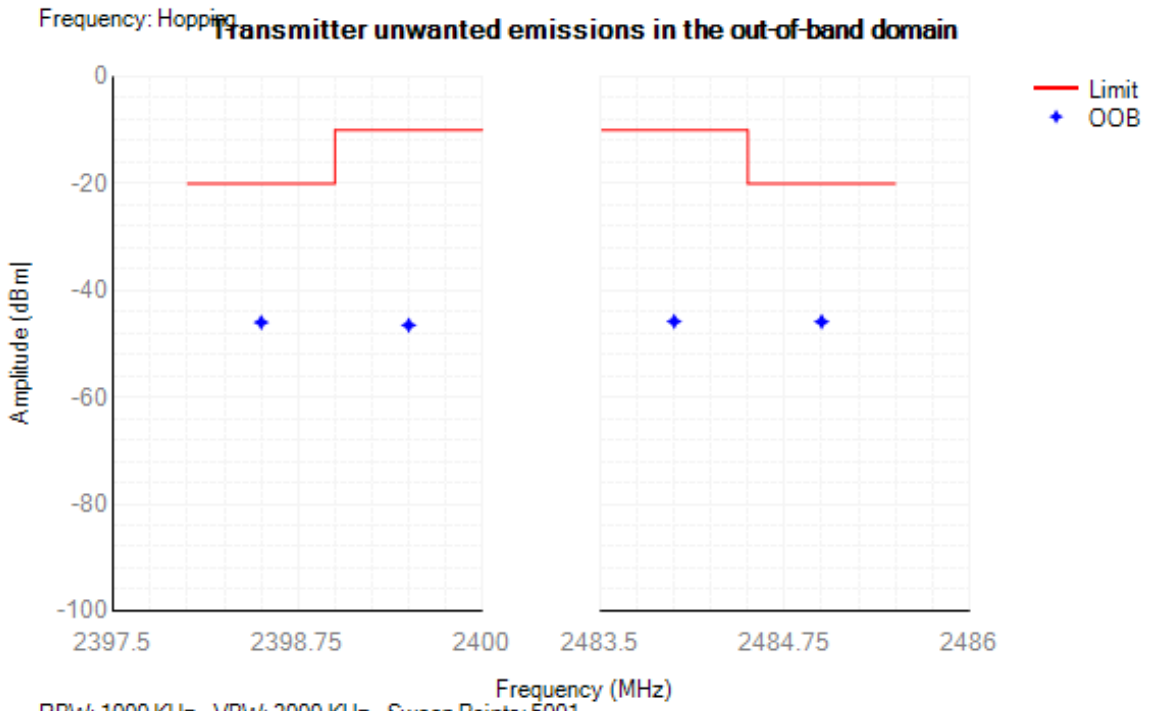

Tx. Emissions OOB NVNT 1-DH5 2480MHz Ant1

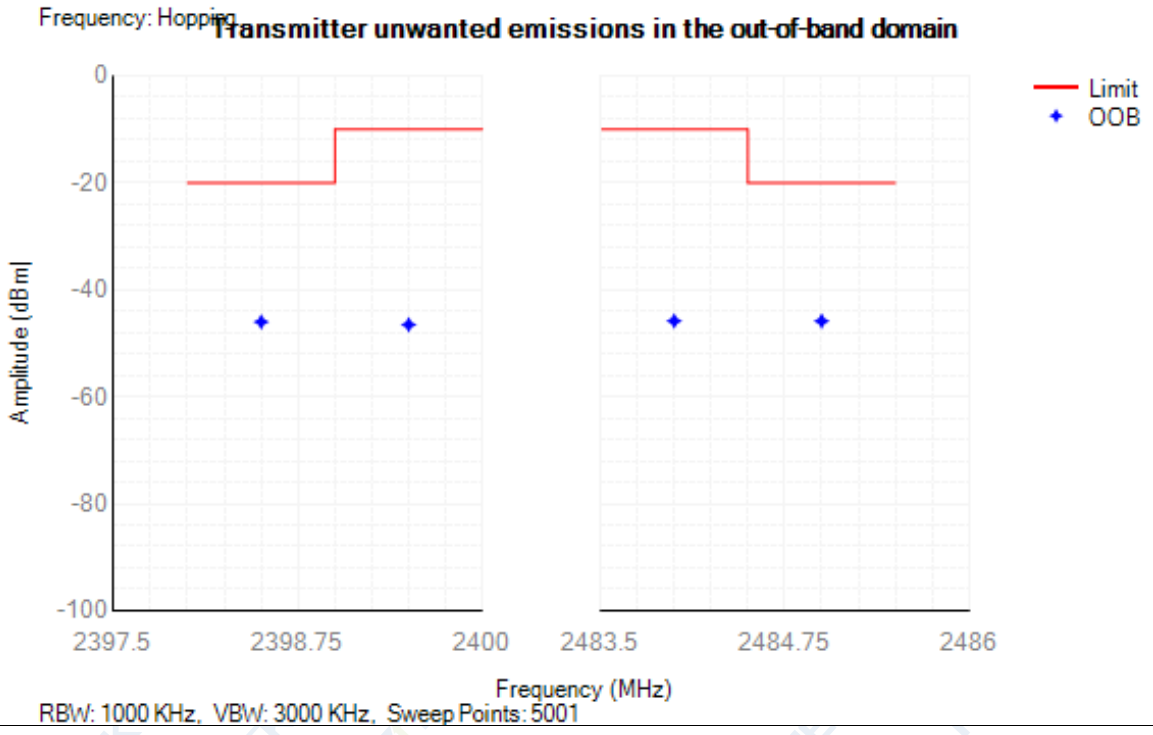

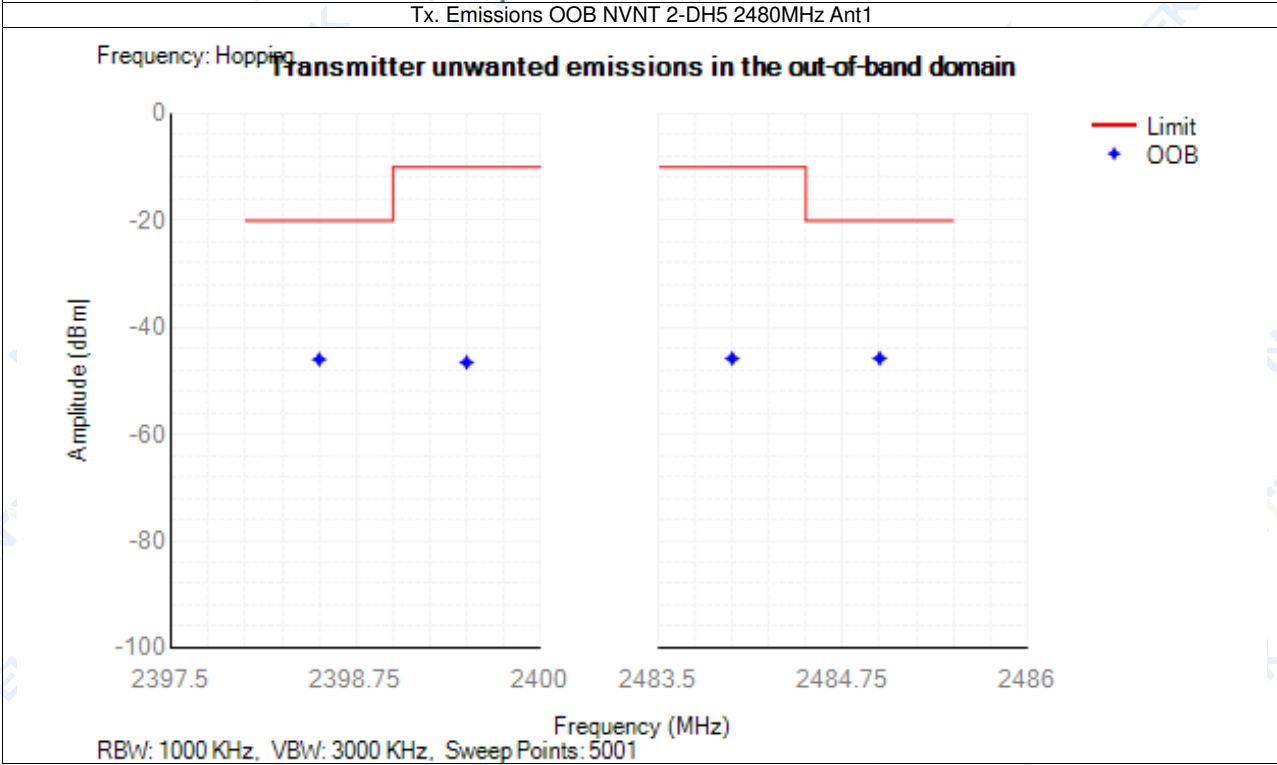
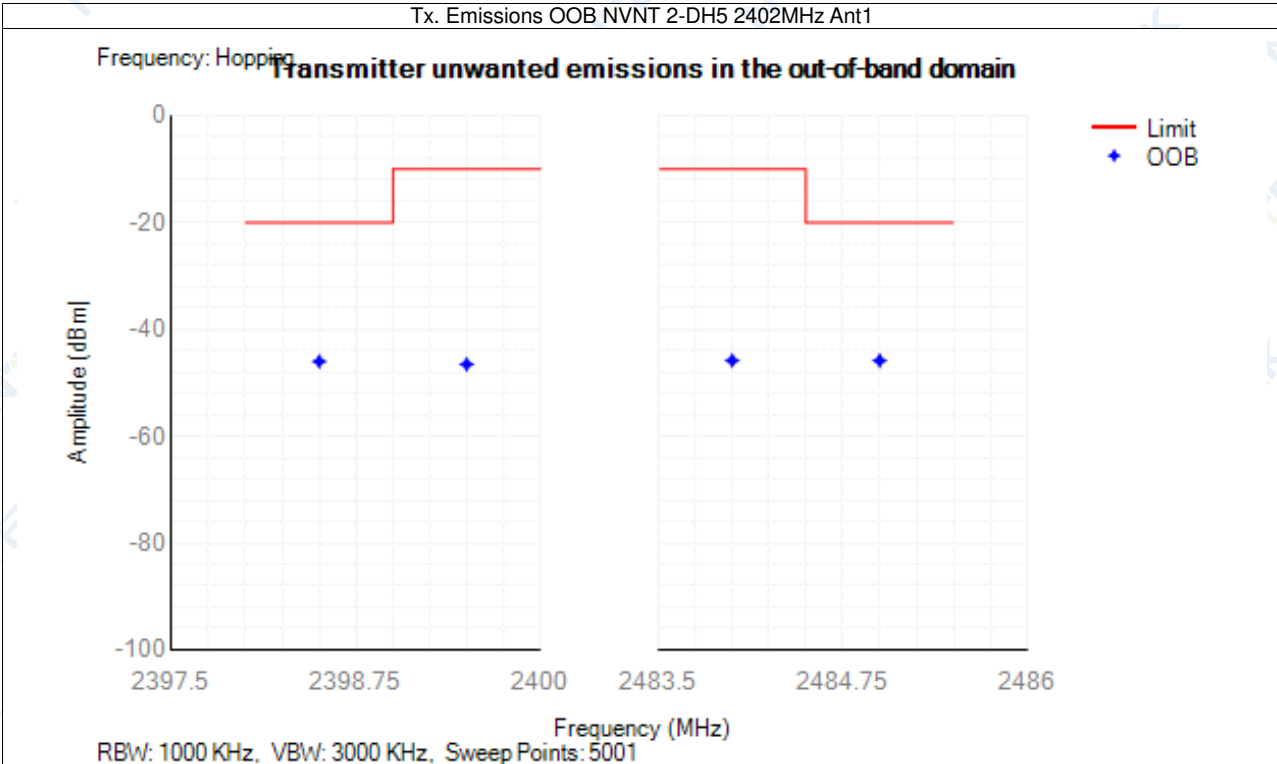

11.8 Transmitter unwanted emissions in the spurious domain

Condition	Mode	Frequency (MHz)	Antenna	Range (MHz)	Spur Freq (MHz)	Peak (dBm)	RMS (dBm)	Limit (dBm)	Verdict
NVNT	1-DH5	2402	Ant1	30 -47	45.65	-75.04	NA	-36	Pass
NVNT	1-DH5	2402	Ant1	47 -74	54.31	-75.27	NA	-54	Pass
NVNT	1-DH5	2402	Ant1	74 -87.5	80.92	-76.23	NA	-36	Pass
NVNT	1-DH5	2402	Ant1	87.5 -118	96.02	-69.98	NA	-54	Pass
NVNT	1-DH5	2402	Ant1	118 -174	160.94	-75.26	NA	-36	Pass
NVNT	1-DH5	2402	Ant1	174 -230	212.81	-73.77	NA	-54	Pass
NVNT	1-DH5	2402	Ant1	230 -470	354.25	-74.21	NA	-36	Pass
NVNT	1-DH5	2402	Ant1	470 -694	559.51	-74.31	NA	-54	Pass
NVNT	1-DH5	2402	Ant1	694 -1000	900.77	-45.71	NA	-36	Pass
NVNT	1-DH5	2402	Ant1	1000 -2398	2210.00	-47.48	NA	-30	Pass
NVNT	1-DH5	2402	Ant1	2485.5 -12750	4804.00	-44.23	NA	-30	Pass
NVNT	1-DH5	534.65	Ant1	30 -47	39.75	-75.27	NA	-36	Pass
NVNT	1-DH5	534.65	Ant1	47 -74	67.10	-75.80	NA	-54	Pass
NVNT	1-DH5	534.65	Ant1	74 -87.5	80.15	-76.32	NA	-36	Pass
NVNT	1-DH5	534.65	Ant1	87.5 -118	96.00	-69.99	NA	-54	Pass
NVNT	1-DH5	534.65	Ant1	118 -174	168.95	-75.03	NA	-36	Pass
NVNT	1-DH5	534.65	Ant1	174 -230	199.95	-73.62	NA	-54	Pass
NVNT	1-DH5	534.65	Ant1	230 -470	288.05	-72.94	NA	-36	Pass
NVNT	1-DH5	534.65	Ant1	470 -694	567.45	-74.02	NA	-54	Pass
NVNT	1-DH5	534.65	Ant1	694 -1000	902.35	-46.73	NA	-36	Pass
NVNT	1-DH5	534.65	Ant1	1000 -2398	2249.00	-46.94	NA	-30	Pass
NVNT	1-DH5	534.65	Ant1	2485.5 -12750	4882.00	-44.01	NA	-30	Pass
NVNT	1-DH5	2480	Ant1	30 -47	42.65	-76.11	NA	-36	Pass
NVNT	1-DH5	2480	Ant1	47 -74	53.10	-76.27	NA	-54	Pass
NVNT	1-DH5	2480	Ant1	74 -87.5	82.95	-76.18	NA	-36	Pass
NVNT	1-DH5	2480	Ant1	87.5 -118	96.00	-68.84	NA	-54	Pass
NVNT	1-DH5	2480	Ant1	118 -174	173.15	-74.55	NA	-36	Pass
NVNT	1-DH5	2480	Ant1	174 -230	191.95	-74.60	NA	-54	Pass
NVNT	1-DH5	2480	Ant1	230 -470	351.20	-74.56	NA	-36	Pass
NVNT	1-DH5	2480	Ant1	470 -694	685.40	-74.54	NA	-54	Pass
NVNT	1-DH5	2480	Ant1	694 -1000	900.90	-46.58	NA	-36	Pass

NVNT	1-DH5	2480	Ant1	1000 -2398	2287.50	-46.45	NA	-30	Pass
NVNT	1-DH5	2480	Ant1	2485.5 -12750	5187.50	-42.54	NA	-30	Pass
NVNT	2-DH5	2402	Ant1	30 -47	44.55	-76.52	NA	-36	Pass
NVNT	2-DH5	2402	Ant1	47 -74	67.30	-75.33	NA	-54	Pass
NVNT	2-DH5	2402	Ant1	74 -87.5	78.70	-75.53	NA	-36	Pass
NVNT	2-DH5	2402	Ant1	87.5 -118	89.60	-75.89	NA	-54	Pass
NVNT	2-DH5	2402	Ant1	118 -174	163.25	-75.32	NA	-36	Pass
NVNT	2-DH5	2402	Ant1	174 -230	182.75	-74.60	NA	-54	Pass
NVNT	2-DH5	2402	Ant1	230 -470	458.45	-73.73	NA	-36	Pass
NVNT	2-DH5	2402	Ant1	470 -694	666.95	-73.94	NA	-54	Pass
NVNT	2-DH5	2402	Ant1	694 -1000	901.55	-46.84	NA	-36	Pass
NVNT	2-DH5	2402	Ant1	1000 -2398	2210.00	-47.94	NA	-30	Pass
NVNT	2-DH5	2402	Ant1	2485.5 -12750	6914.50	-44.23	NA	-30	Pass
NVNT	2-DH5	2441	Ant1	30 -47	42.65	-75.61	NA	-36	Pass
NVNT	2-DH5	2441	Ant1	47 -74	67.95	-74.88	NA	-54	Pass
NVNT	2-DH5	2441	Ant1	74 -87.5	86.30	-76.15	NA	-36	Pass
NVNT	2-DH5	2441	Ant1	87.5 -118	96.00	-70.70	NA	-54	Pass
NVNT	2-DH5	2441	Ant1	118 -174	163.60	-75.06	NA	-36	Pass
NVNT	2-DH5	2441	Ant1	174 -230	191.95	-74.07	NA	-54	Pass
NVNT	2-DH5	2441	Ant1	230 -470	253.65	-74.18	NA	-36	Pass
NVNT	2-DH5	2441	Ant1	470 -694	533.15	-74.29	NA	-54	Pass
NVNT	2-DH5	2441	Ant1	694 -1000	879.30	-73.59	NA	-36	Pass
NVNT	2-DH5	2441	Ant1	1000 -2398	2248.50	-47.54	NA	-30	Pass
NVNT	2-DH5	2441	Ant1	2485.5 -12750	5181.00	-40.12	NA	-30	Pass
NVNT	2-DH5	2480	Ant1	30 -47	32.75	-76.01	NA	-36	Pass
NVNT	2-DH5	2480	Ant1	47 -74	68.40	-75.92	NA	-54	Pass
NVNT	2-DH5	2480	Ant1	74 -87.5	85.95	-75.94	NA	-36	Pass
NVNT	2-DH5	2480	Ant1	87.5 -118	113.75	-75.65	NA	-54	Pass
NVNT	2-DH5	2480	Ant1	118 -174	168.10	-75.24	NA	-36	Pass
NVNT	2-DH5	2480	Ant1	174 -230	192.05	-74.91	NA	-54	Pass
NVNT	2-DH5	2480	Ant1	230 -470	288.05	-72.29	NA	-36	Pass
NVNT	2-DH5	2480	Ant1	470 -694	657.00	-75.07	NA	-54	Pass
NVNT	2-DH5	2480	Ant1	694 -1000	924.10	-73.47	NA	-36	Pass
NVNT	2-DH5	2480	Ant1	1000 -2398	2288.00	-46.40	NA	-30	Pass

NVNT	2-DH5	2480	Ant1	2485.5 -12750	4960.00	-44.55	NA	-30	Pass
------	-------	------	------	------------------	---------	--------	----	-----	------

Test Graphs

Tx. Spurious NVNT 1-DH5 2402MHz Ant1

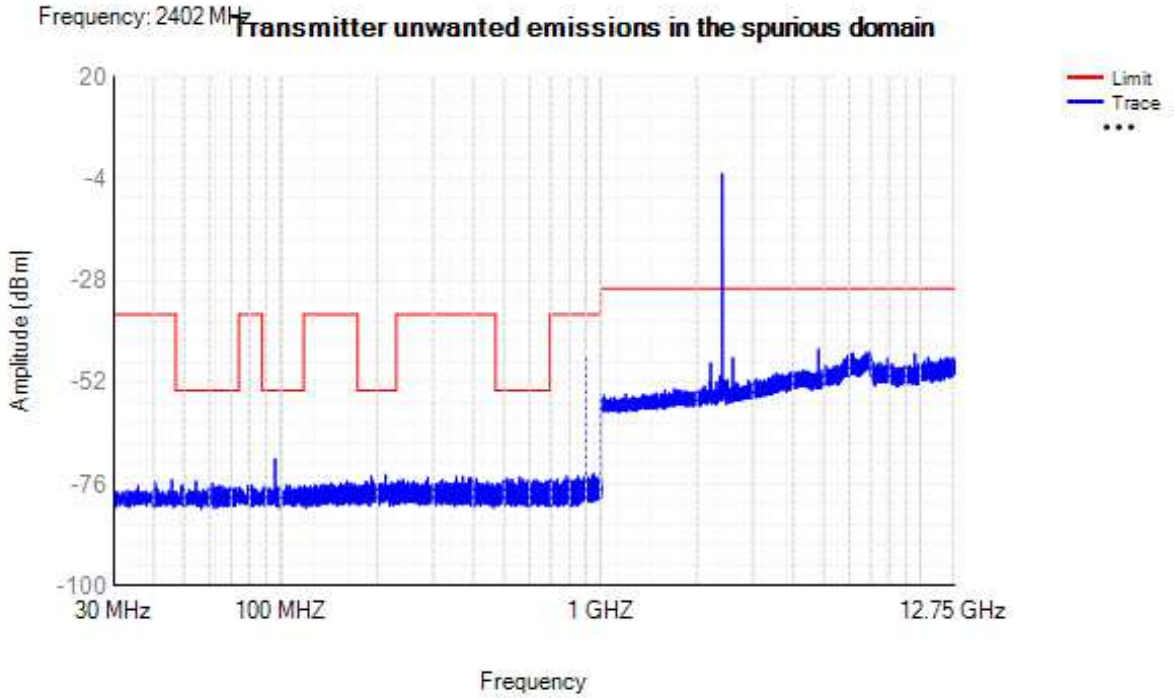

Tx. Spurious NVNT 1-DH5 534.65MHz Ant1

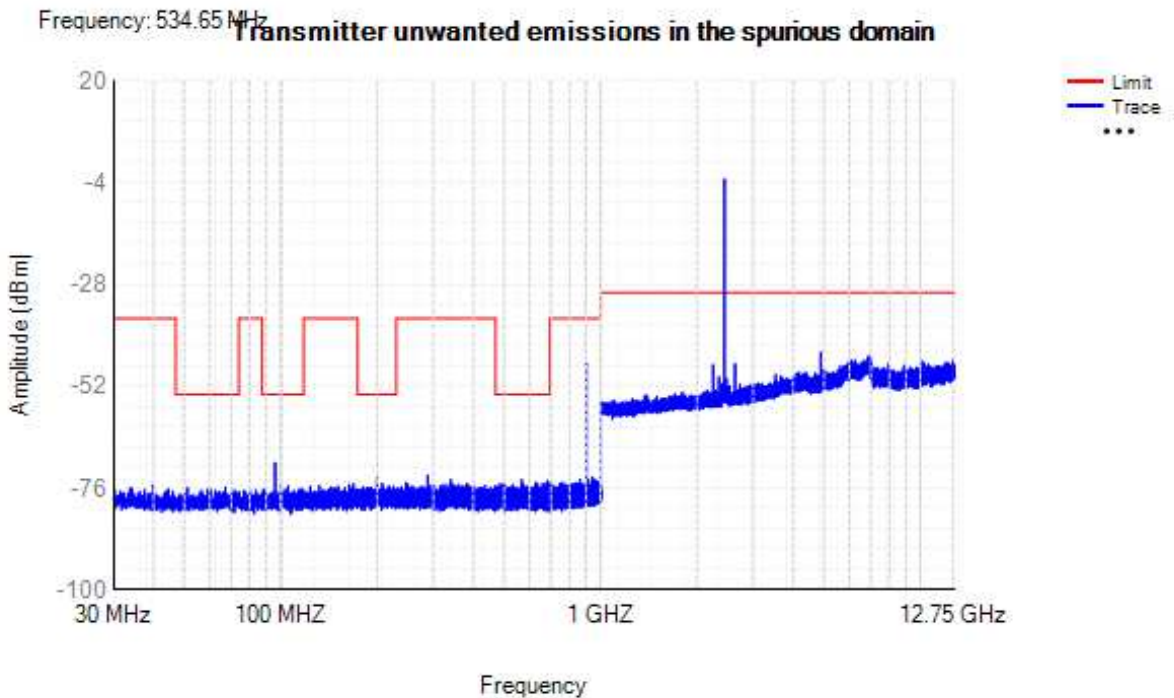

Tx. Spurious NVNT 1-DH5 2480MHz Ant1

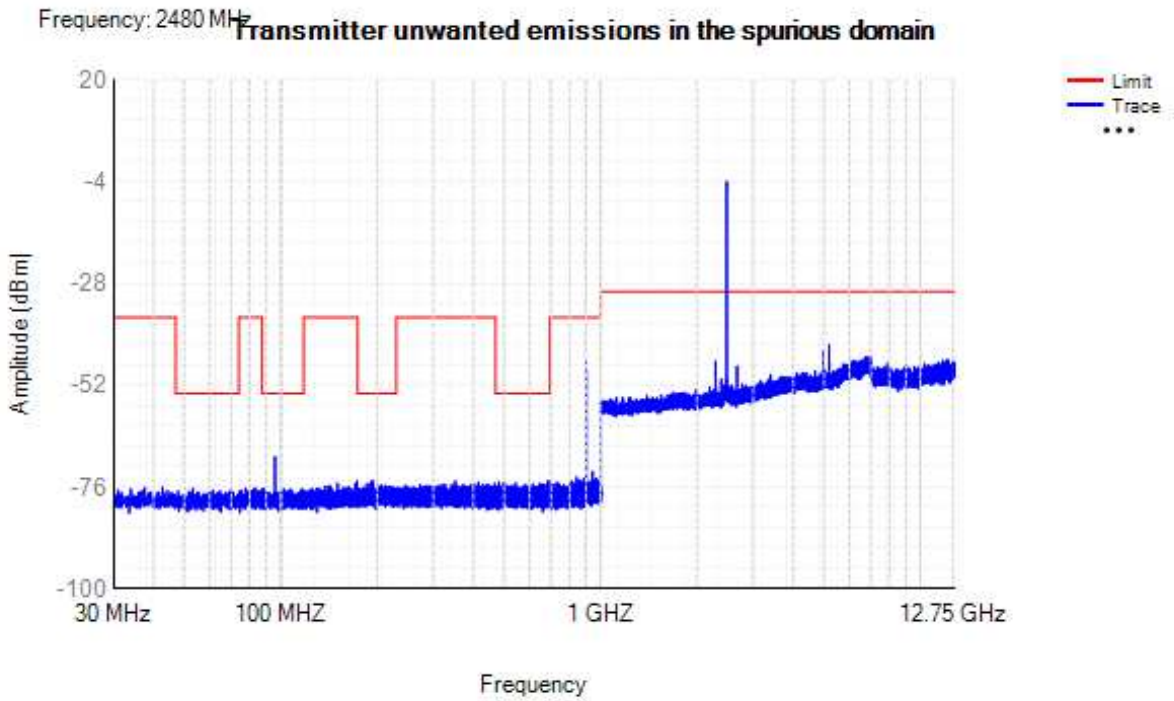

Tx. Spurious NVNT 2-DH5 2402MHz Ant1

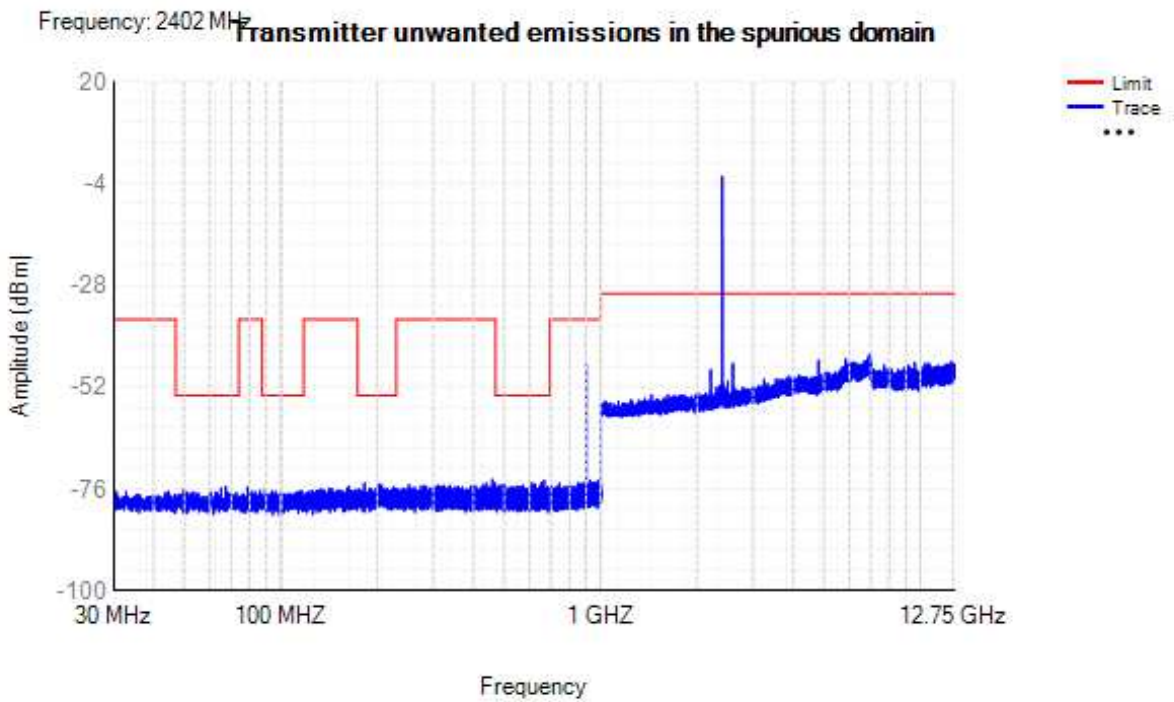

Tx. Spurious NVNT 2-DH5 2441MHz Ant1

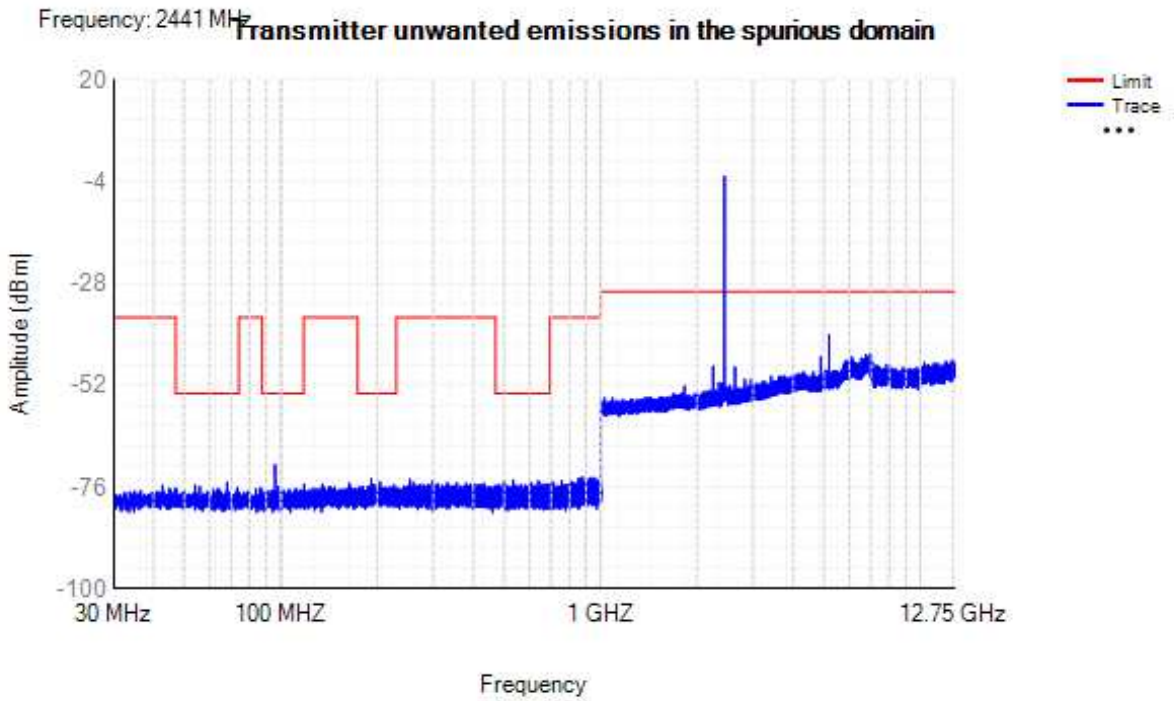

Tx. Spurious NVNT 2-DH5 2480MHz Ant1

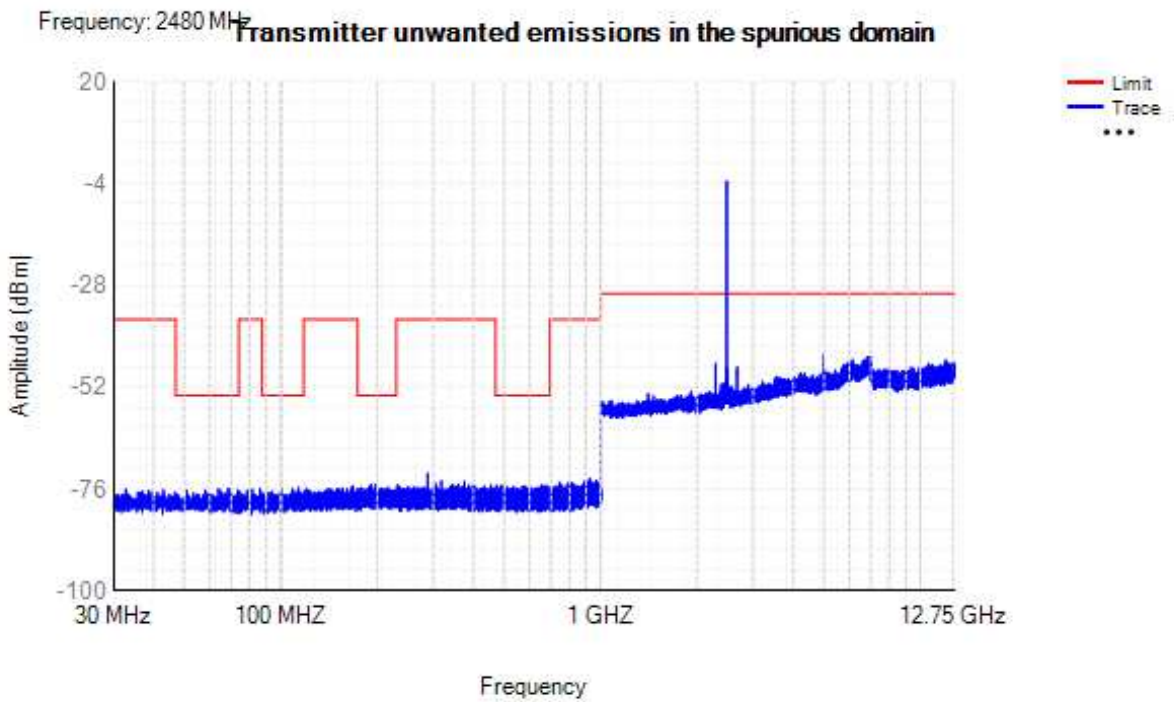

11.9 Receiver spurious emissions

Condition	Mode	Frequency (MHz)	Antenna	Range (MHz)	Spur Freq (MHz)	Peak (dBm)	RMS (dBm)	Limit (dBm)	Verdict
NVNT	1-DH5	2402	Ant1	30 -1000	888.35	-74.58	NA	-57	Pass
NVNT	1-DH5	2402	Ant1	1000 -12750	6866.5	-55.67	NA	-47	Pass
NVNT	1-DH5	2441	Ant1	30 -1000	975.15	-74.46	NA	-57	Pass
NVNT	1-DH5	2441	Ant1	1000 -12750	2529.5	-53.43	NA	-47	Pass
NVNT	1-DH5	2480	Ant1	30 -1000	691.2	-74.41	NA	-57	Pass
NVNT	1-DH5	2480	Ant1	1000 -12750	2528	-54.79	NA	-47	Pass
NVNT	2-DH5	2402	Ant1	30 -1000	955.75	-73.26	NA	-57	Pass
NVNT	2-DH5	2402	Ant1	1000 -12750	6889.5	-55.30	NA	-47	Pass
NVNT	2-DH5	2441	Ant1	30 -1000	943.1	-74.29	NA	-57	Pass
NVNT	2-DH5	2441	Ant1	1000 -12750	6983	-55.42	NA	-47	Pass
NVNT	2-DH5	2480	Ant1	30 -1000	874.85	-74.27	NA	-57	Pass
NVNT	2-DH5	2480	Ant1	1000 -12750	6852.5	-55.50	NA	-47	Pass

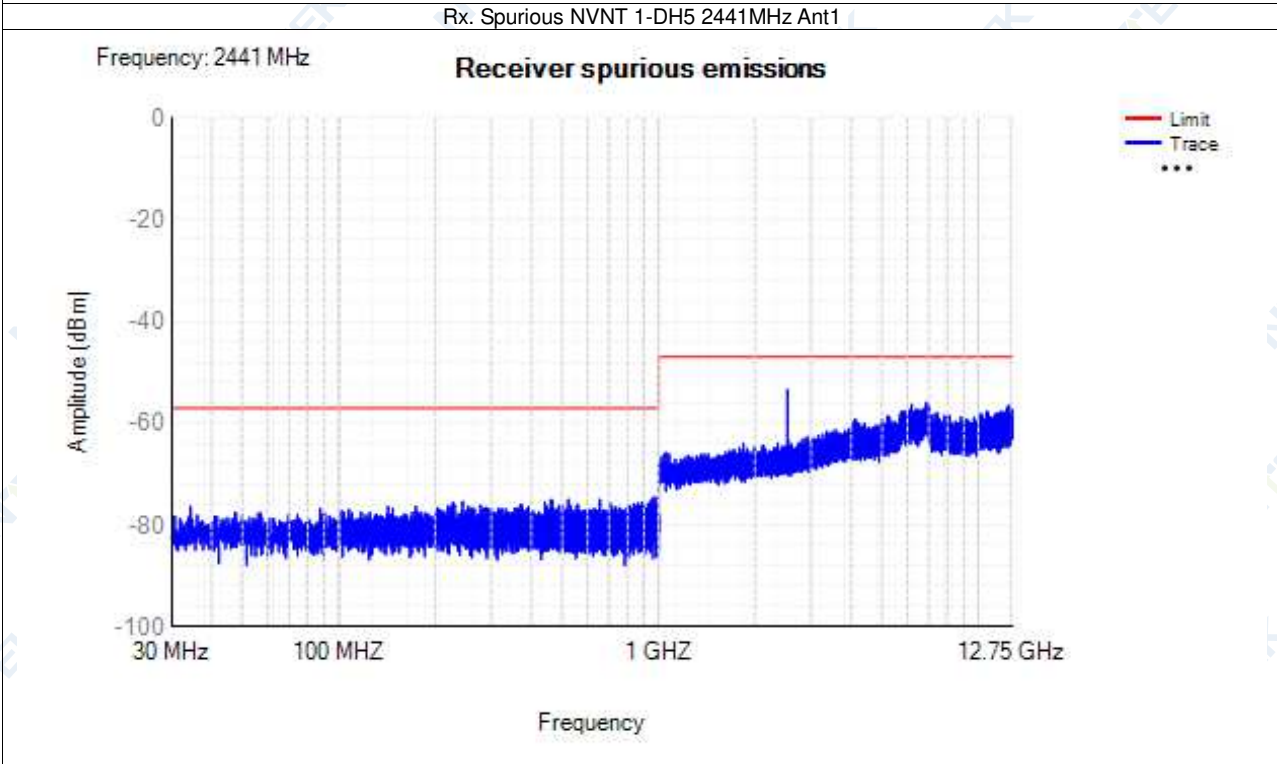
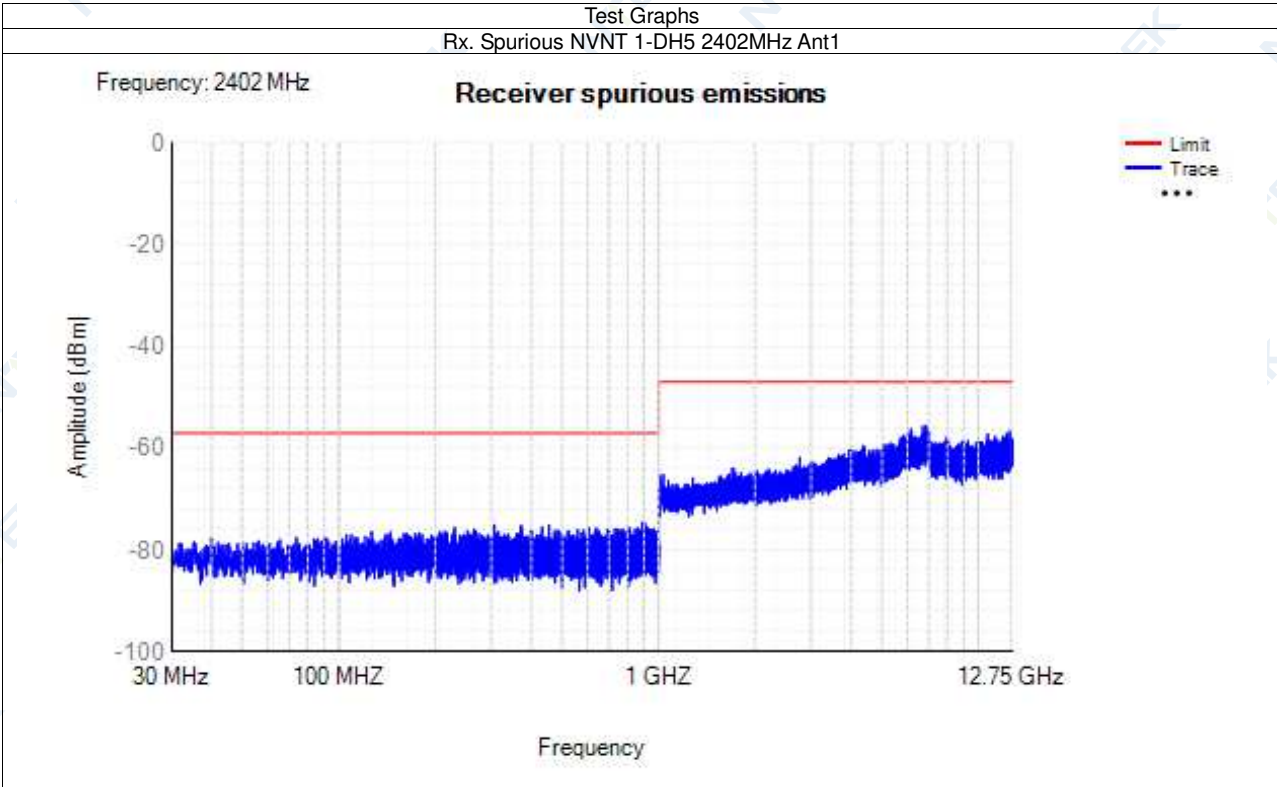

Rx. Spurious NVNT 1-DH5 2480MHz Ant1

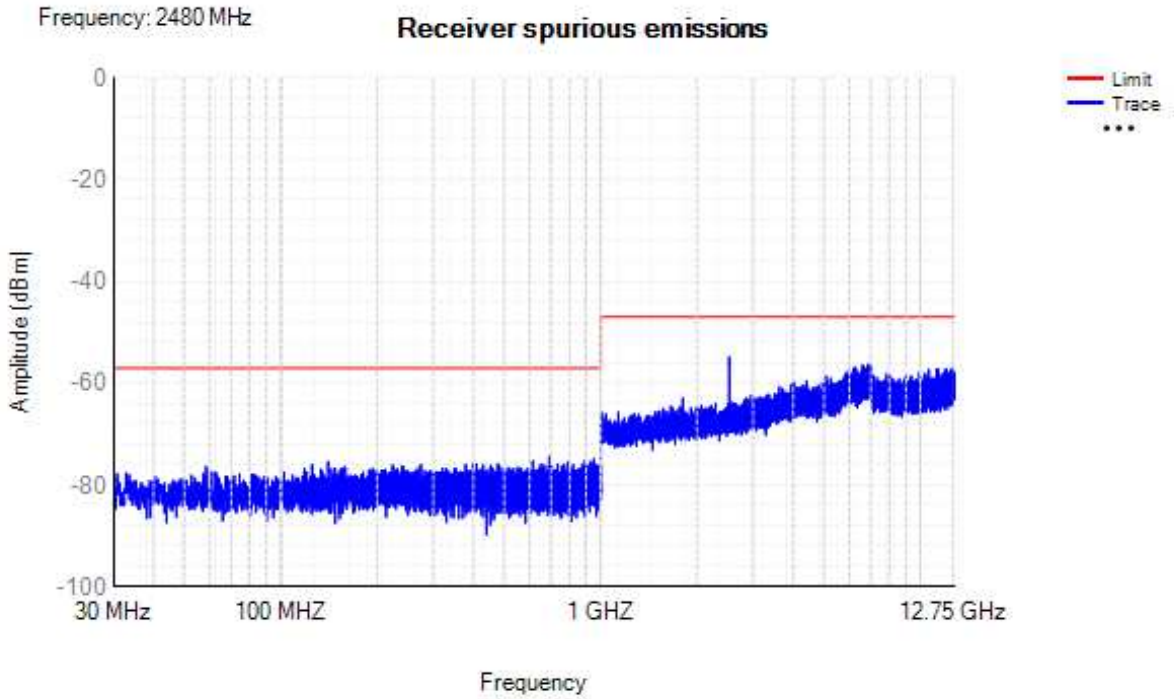

Rx. Spurious NVNT 2-DH5 2402MHz Ant1

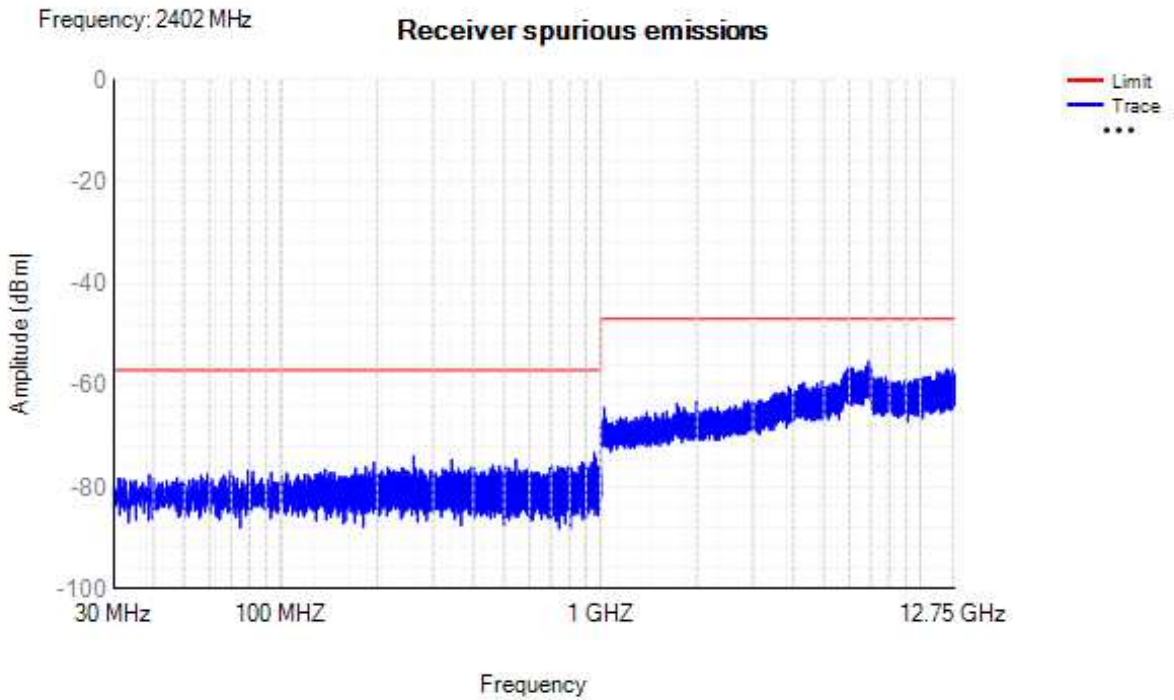

Rx. Spurious NVNT 2-DH5 2441MHz Ant1

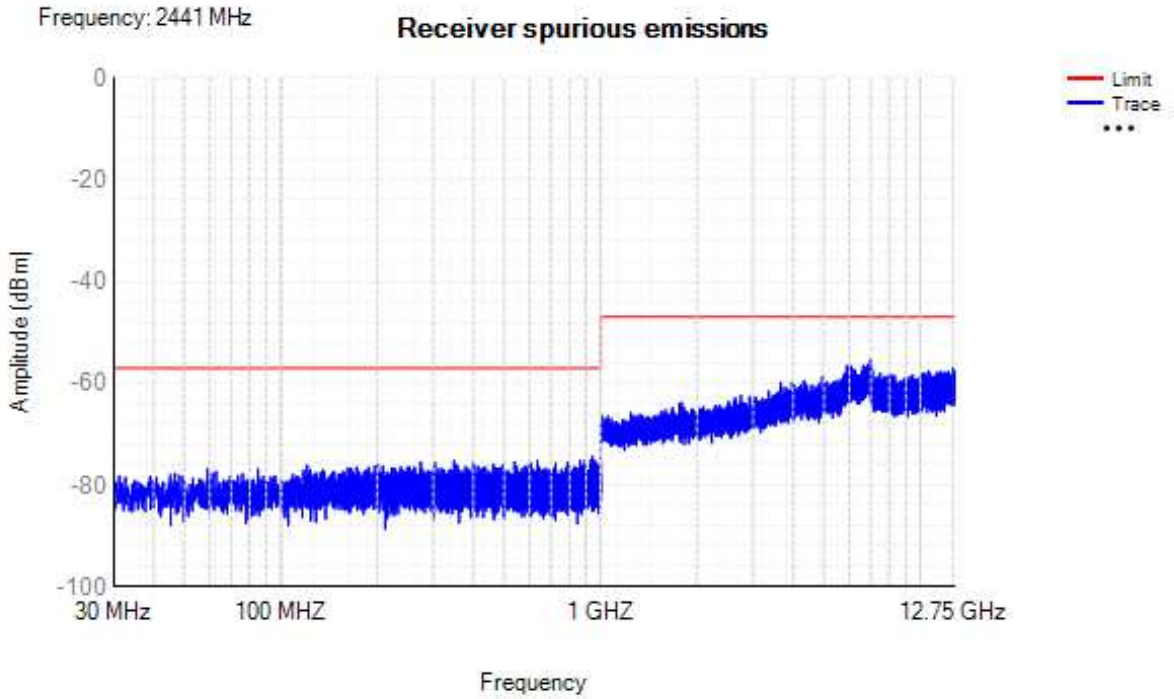

Rx. Spurious NVNT 2-DH5 2480MHz Ant1

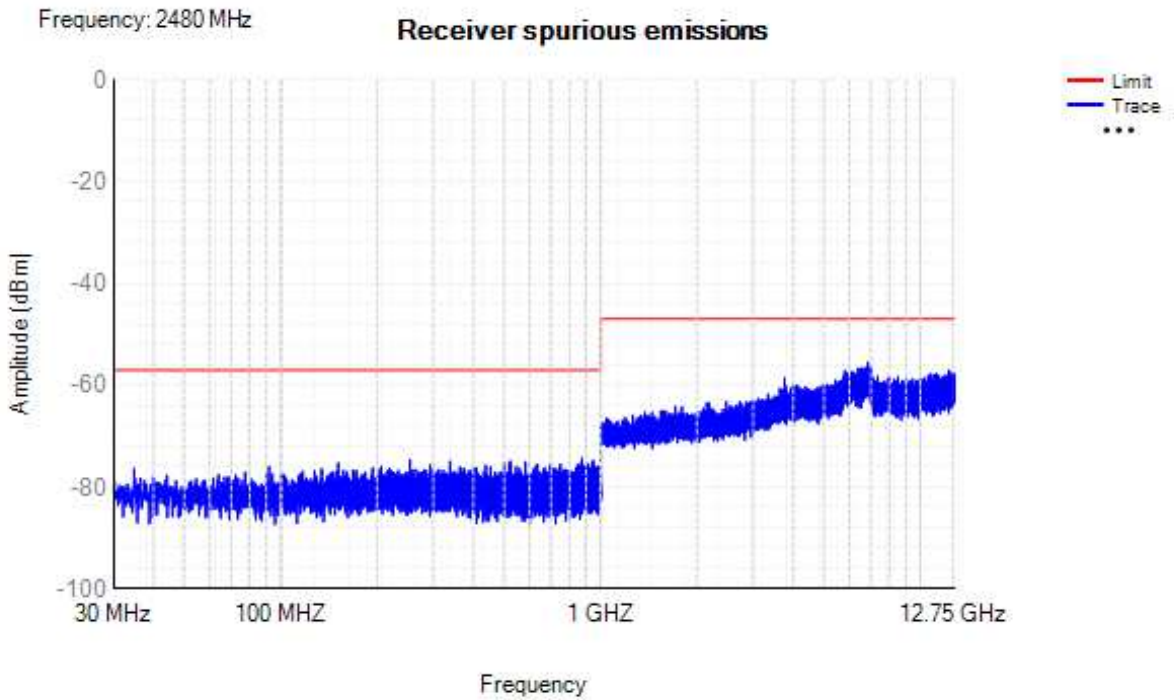

11.10 Hopping Sequence

Condition	Mode	Antenna	Hopping Number	Limit	Band Allocation (%)	Limit Band Allocation (%)	Verdict
NVNT	1-DH5	Ant1	79	15	70.4	70	Pass
NVNT	2-DH5	Ant1	79	15	96.2	70	Pass

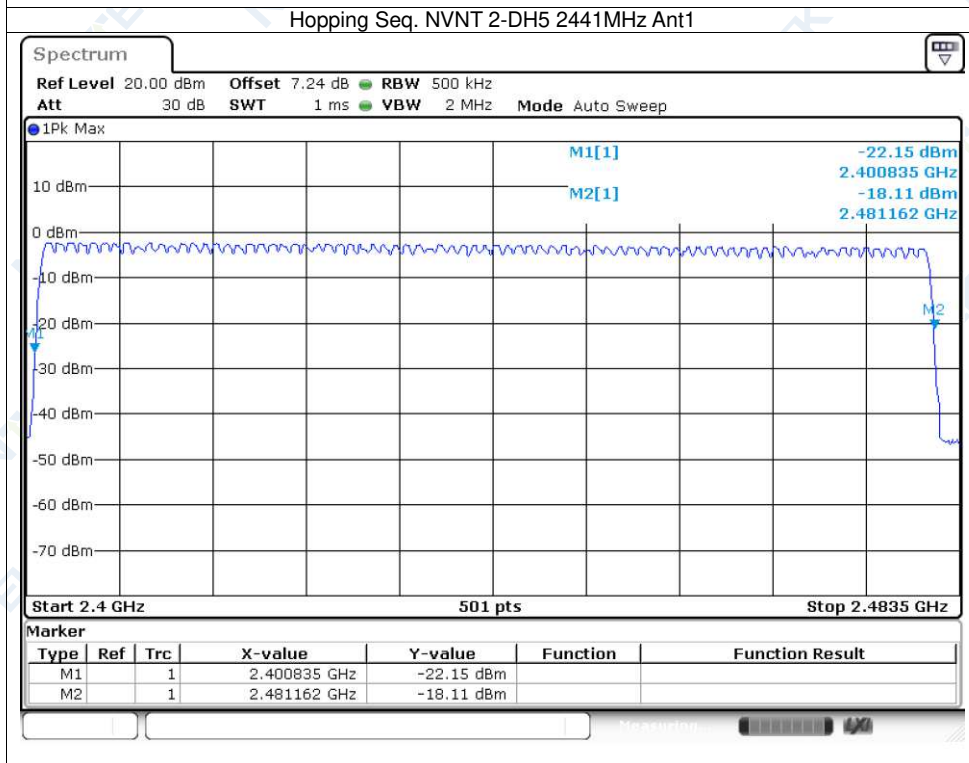
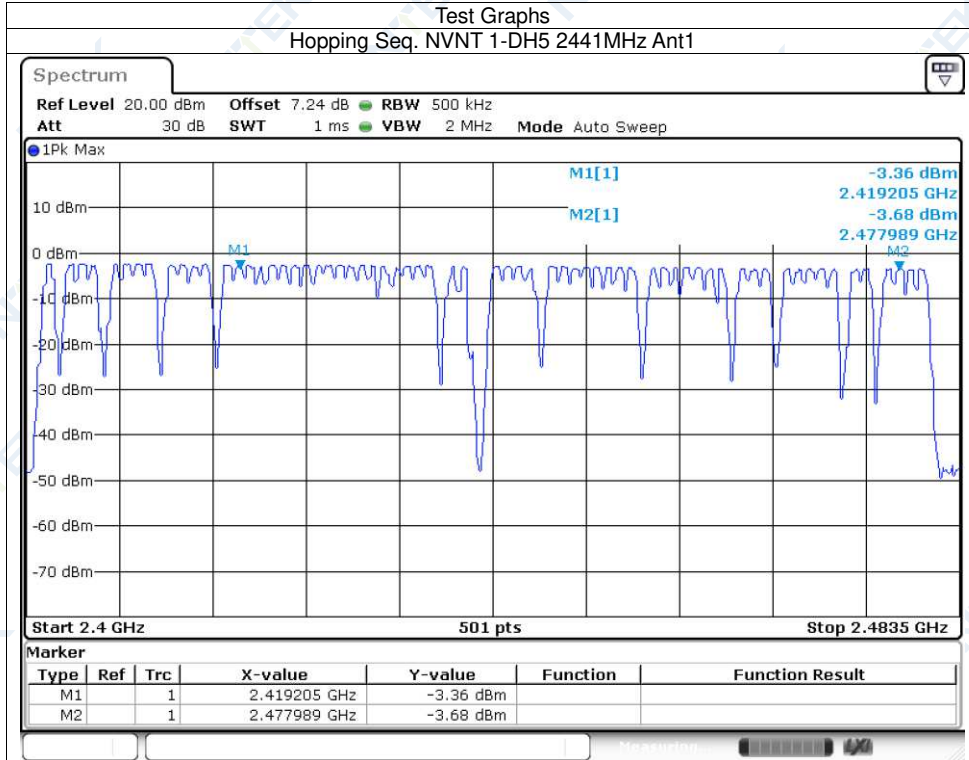

12. EUT TEST PHOTO

SPURIOUS EMISSIONS MEASUREMENT PHOTOS

Left

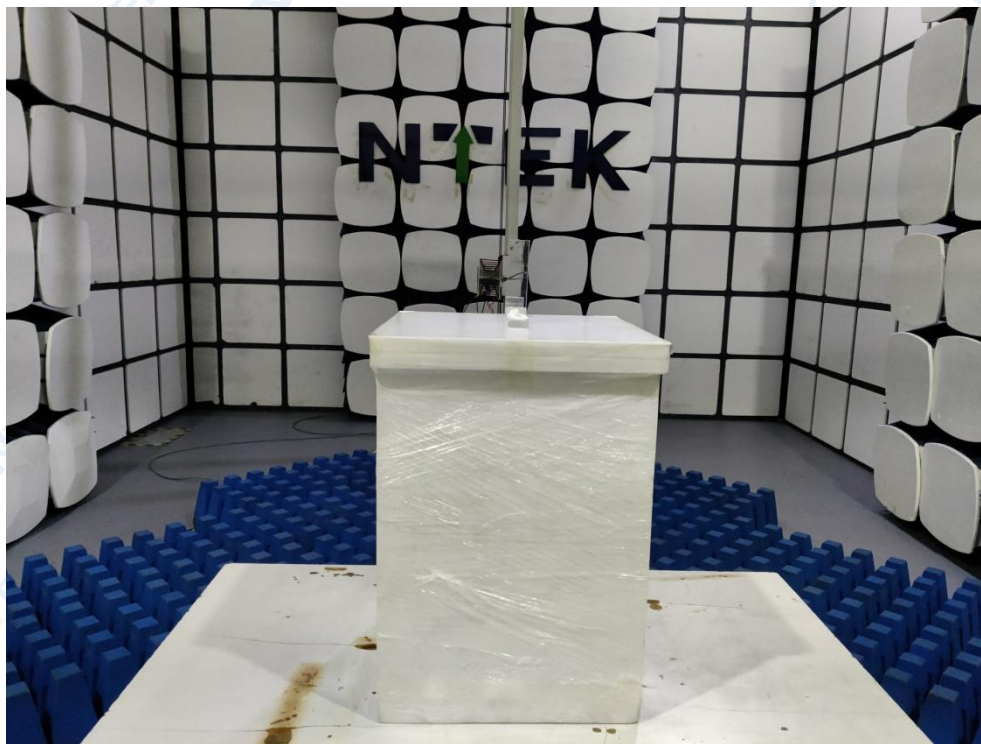
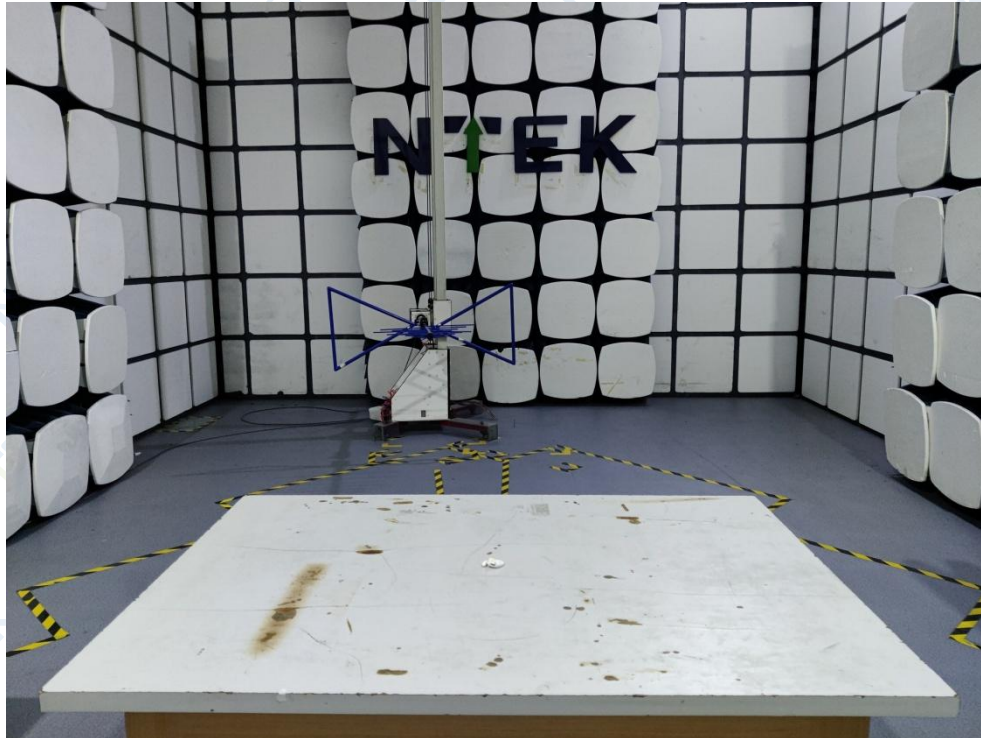

Right

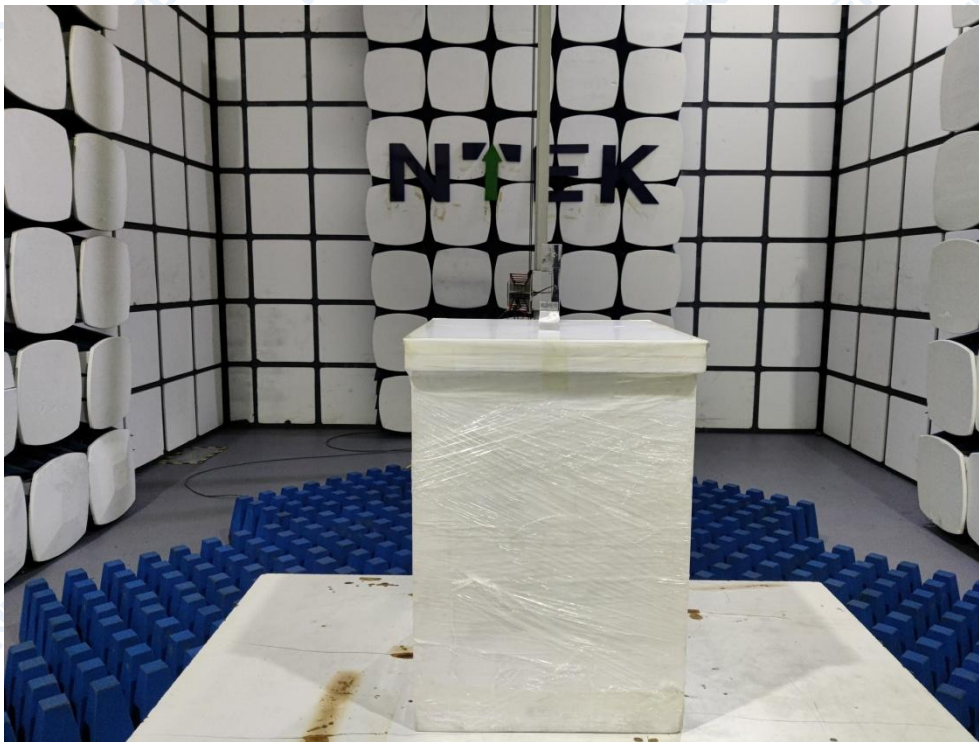
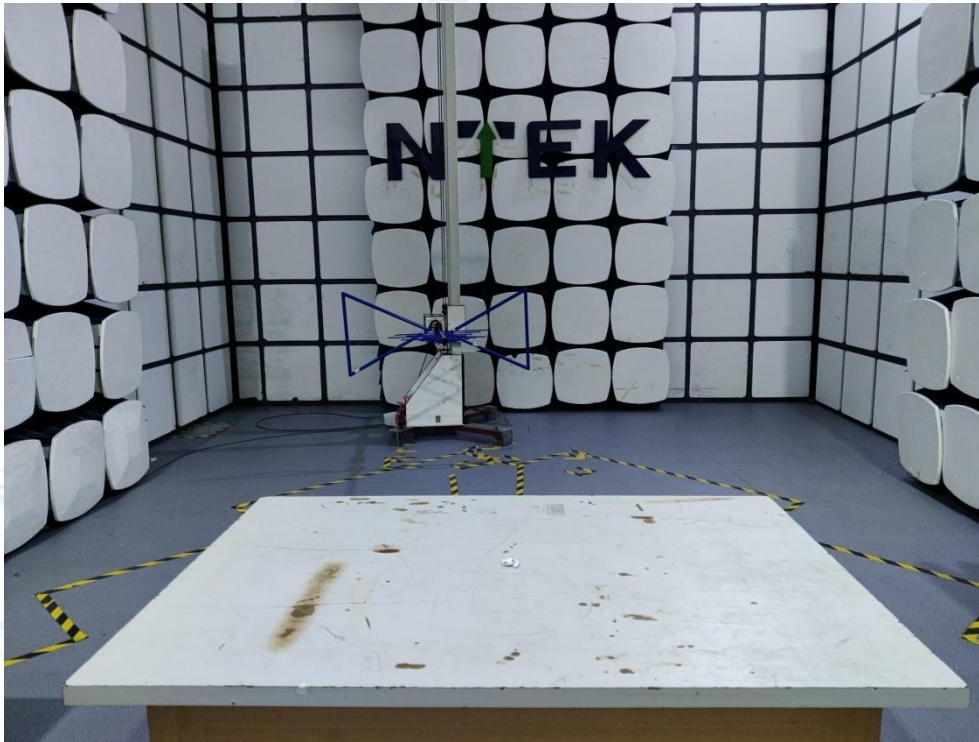

END OF REPORT