



# **RADIO TEST REPORT**

## **ETSI EN 300 328 V2.2.2 (2019-07)**

**Product** : Smart phone

**Trade Mark** : Blackview

**Model Name** : A53 Pro

**Family Model** : N/A

**Report No.** : STR221215001001E

### **Prepared for**

DOKE COMMUNICATION (HK) LIMITED

RM 1902 EASEY COMM BLDG 253-261 HENNESSY ROAD WANCHAI HK CHINA

### **Prepared by**

Shenzhen NTEK Testing Technology Co., Ltd.

1/F, Building E, Fenda Science Park, Sanwei Community, Xixiang Street  
Bao'an District, Shenzhen 518126 P.R. China

Tel. 400-800-6106, 0755-2320 0050, 0755-2320 0090

Website: <http://www.ntek.org.cn>

TEST RESULT CERTIFICATION

Applicant's name : DOKE COMMUNICATION (HK) LIMITED
Address : RM 1902 EASEY COMM BLDG 253-261 HENNESSY ROAD
WANCHAI HK CHINA

Manufacturer's Name : Shenzhen DOKE Electronic Co.,Ltd
Address : 801, Building3, 7th Industrial Zone, Yulv Community, Yutang
Road, Guangming District, Shenzhen, China

Product description

Product name : Smart phone
Trademark : Blackview
Model Name : A53 Pro
Family Model : N/A

Standards : ETSI EN 300 328 V2.2.2 (2019-07)

This device described above has been tested by NTEK, and the test results show that the
equipment under test (EUT) is in compliance with the of article 3.2 of the Directive 2014/53/EU
requirements. And it is applicable only to the tested sample identified in the report.

This report shall not be reproduced except in full, without the written approval of NTEK, this
document may be altered or revised by NTEK, personnel only, and shall be noted in the revision of
the document.

Test Sample Number : T221215001R003

Date of Test

Date (s) of performance of tests : Dec 15, 2022 ~ Jan 03, 2023

Date of Issue : Jan 03, 2023

Test Result : Pass

Testing Engineer : [Signature]
(Mary Hu)

Authorized Signatory : [Signature]
(Alex Li)

**Table of Contents**

**Page**

1 . GENERAL INFORMATION	7
1.1 GENERAL DESCRIPTION OF EUT	7
1.2 INFORMATION ABOUT THE EUT	8
1.3 TEST CONDITIONS	13
1.4 TEST CONFIGURATION OF EUT	13
1.5 DESCRIPTION OF TEST CONDITIONS	14
1.6 DESCRIPTION OF SUPPORT UNITS	15
1.7 EQUIPMENTS LIST FOR ALL TEST ITEMS	16
2 . SUMMARY OF TEST RESULTS	17
2.1 TEST FACILITY	18
3 . RF OUTPUT POWER	19
3.1 LIMITS OF RF OUTPUT POWER	19
3.2 TEST PROCEDURE	19
3.3 DEVIATION FROM TEST STANDARD	19
3.4 TEST SETUP	19
3.5 TEST RESULTS	20
4 . ACCUMULATED TRANSMIT TIME, FREQUENCY OCCUPATION AND HOPPING SEQUENCE	21
4.1 LIMITS OF ACCUMULATED TRANSMIT TIME, FREQUENCY OCCUPATION AND HOPPING SEQUENCE	21
4.2 TEST PROCEDURE	21
4.3 DEVIATION FROM TEST STANDARD	21
4.4 TEST SETUP	22
4.5 TEST RESULTS	22
5 . OCCUPIED CHANNEL BANDWIDTH	23
5.1 LIMITS OF OCCUPIED CHANNEL BANDWIDTH	23
5.2 TEST PROCEDURE	23
5.3 DEVIATION FROM TEST STANDARD	24
5.4 TEST SETUP	24
5.5 TEST RESULTS	24
6 . TRANSMITTER UNWANTED EMISSIONS IN THE OUT-OF-BAND DOMAIN	25
6.1 LIMITS OF TRANSMITTER UNWANTED EMISSIONS IN THE OUT-OF-BAND DOMAIN	25

**Table of Contents**

**Page**

6.2 TEST PROCEDURE	25
6.3 DEVIATION FROM TEST STANDARD	26
6.4 TEST SETUP	26
6.5 TEST RESULTS	26
7 . HOPPING FREQUENCY SEPARATION	27
7.1 LIMITS OF HOPPING FREQUENCY SEPARATION	27
7.2 TEST PROCEDURE	27
7.3 DEVIATION FROM TEST STANDARD	27
7.4 TEST SETUP	28
7.5 TEST RESULTS	28
8 . TRANSMITTER UNWANTED EMISSIONS IN THE SPURIOUS DOMAIN	29
8.1 LIMITS OF TRANSMITTER TRANSMITTER UNWANTED EMISSIONS IN THE SPURIOUS DOMAIN	29
8.2 TEST PROCEDURE	29
8.3 DEVIATION FROM TEST STANDARD	29
8.4 TEST SETUP	30
8.5 TEST RESULTS (Radiated measurement)	31
8.6 TEST RESULTS (Conducted measurement)	32
9 . RECEIVER SPURIOUS EMISSIONS	33
9.1 LIMITS OF RECEIVER SPURIOUS RADIATION	33
9.2 TEST PROCEDURE	33
9.3 DEVIATION FROM TEST STANDARD	33
9.4 TEST SETUP	34
9.5 TEST RESULTS (Radiated measurement)	35
9.6 TEST RESULTS (Conducted measurement)	36
10. RECEIVER BLOCKING	37
10.1 PERFORMANCE CRITERIA	37
10.2 LIMITS OF RECEIVER BLOCKING	37
10.3 TEST PROCEDURE	38
10.4 DEVIATION FROM TEST STANDARD	39
10.5 TEST SETUP	39
10.6 TEST RESULTS	40
11. TEST RESULTS	43
11.1 Accumulated Transmit Time	43



<b>Table of Contents</b>	<b>Page</b>
11.2 Frequency Occupation	53
11.3 Dwell Time One Burst	63
11.4 RF Output Power	73
11.5 Hopping Frequency Separation	76
11.6 Occupied Channel Bandwidth	82
11.7 Transmitter unwanted emissions in the out-of-band domain	85
11.8 Transmitter unwanted emissions in the spurious domain	89
11.9 Receiver spurious emissions	96
11.10 Hopping Sequence	102
12. EUT TEST PHOTO	105
SPURIOUS EMISSIONS MEASUREMENT PHOTOS	105



### 1. GENERAL INFORMATION

#### 1.1 GENERAL DESCRIPTION OF EUT

Equipment	Smart phone	
Trade Mark	Blackview	
Model Name.	A53 Pro	
Family Model	N/A	
Model Difference	N/A	
Product Description	The EUT is Smart phone	
	Operation Frequency:	2402~2480 MHz
	Modulatin Type:	GFSK,π/4-DQPSK,8-DPSK
	Modulation Technology:	FHSS
	Adaptive/non-adaptive	Adaptive equipment
	Receiver categories	2
	Number Of Channel	79CH
	Antenna Designation:	PIFA Antenna
	Antenna Gain(Peak)	1.0 dBi
	Based on the application, features, or specification exhibited in User's Manual, the EUT is considered as an ITE/Computing Device. More details of EUT technical specification, please refer to the User's Manual.	
Channel List	Refer to below Table	
Adapter	Model: QZ-01000EA00 Input: 100-240V~50/60Hz 0.3A Output: 5.0V---2.0A (10.0W)	
Battery	DC 3.87V, 5080mAh, 19.66Wh	
Rating	DC 3.87V from battery or DC 5V from adapter	
I/O Ports	Refer to users manual	
Hardware Version	HCT-M659MB-A2	
Software Version	A53Pro_EEA_M659_V1.0	

**Note:**

1. For a more detailed features description, please refer to the manufacturer's specifications or the User's Manual.

2.

79 channels are provided to (GFSK,  $\pi/4$ -DQPSK, 8-DPSK)

Channel	Frequency (MHz)
00	2402
01	2403
.....	.....
.....	.....
.....	...
.....	.....
77	2479
78	2480

**1.2 INFORMATION ABOUT THE EUT**

**a) The type of modulation used by the equipment:**

- FHSS
- other forms of modulation

**b) In case of FHSS modulation:**

- In case of non-Adaptive Frequency Hopping equipment:  
The number of Hopping Frequencies: .....
- In case of Adaptive Frequency Hopping Equipment:  
The maximum number of Hopping Frequencies: 79  
The minimum number of Hopping Frequencies: 79
- The (average) Dwell Time: 357.864ms Maximum

**c) Adaptive / non-adaptive equipment:**

- non-adaptive Equipment
- adaptive Equipment without the possibility to switch to a non-adaptive mode
- adaptive Equipment which can also operate in a non-adaptive mode

**d) In case of adaptive equipment:**

The maximum Channel Occupancy Time implemented by the equipment: .... / ..... ms

- The equipment has implemented an LBT based DAA mechanism
  - In case of equipment using modulation different from FHSS:
    - The equipment is Frame Based equipment
    - The equipment is Load Based equipment
    - The equipment can switch dynamically between Frame Based and Load Based equipment

The CCA time implemented by the equipment: ..... / ..  $\mu$ s

- The equipment has implemented a non-LBT based DAA mechanism
- The equipment can operate in more than one adaptive mode

**e) In case of non-adaptive Equipment:**

The maximum RF Output Power (e.i.r.p.):

The maximum (corresponding) Duty Cycle:

Equipment with dynamic behaviour, that behaviour is described here. (e.g. the different combinations of duty cycle and corresponding power levels to be declared):

**f) The worst case operational mode for each of the following tests:**

- RF Output Power  
GFSK
- Power Spectral Density  
N/A
- Duty cycle, Tx-Sequence, Tx-gap  
N/A
- Accumulated Transmit time, Frequency Occupation & Hopping Sequence (only for FHSS equipment)  
8-DPSK
- Hopping Frequency Separation (only for FHSS equipment)  
8-DPSK
- Medium Utilization  
N/A
- Adaptivity  
N/A
- Receiver Blocking  
8-DPSK
- Nominal Channel Bandwidth  
8-DPSK
- Transmitter unwanted emissions in the OOB domain  
GFSK
- Transmitter unwanted emissions in the spurious domain  
GFSK
- Receiver spurious emissions  
GFSK

**g) The different transmit operating modes (tick all that apply):**

- Operating mode 1: Single Antenna Equipment
- Equipment with only one antenna
- Equipment with two diversity antennas but only one antenna active at any moment in time
- Smart Antenna Systems with two or more antennas, but operating in a (legacy) mode where only one antenna is used (e.g. IEEE 802.11™ [i.3] legacy mode in smart antenna systems)
- Operating mode 2: Smart Antenna Systems - Multiple Antennas without beam forming
- Single spatial stream / Standard throughput / (e.g. IEEE 802.11™ [i.3] legacy mode)
- High Throughput (> 1 spatial stream) using Nominal Channel Bandwidth 1
- High Throughput (> 1 spatial stream) using Nominal Channel Bandwidth 2

NOTE 1: Add more lines if more channel bandwidths are supported.

- Operating mode 3: Smart Antenna Systems - Multiple Antennas with beam forming
- Single spatial stream / Standard throughput (e.g. IEEE 802.11™ [i.3] legacy mode)
- High Throughput (> 1 spatial stream) using Nominal Channel Bandwidth 1
- High Throughput (> 1 spatial stream) using Nominal Channel Bandwidth 2

NOTE 2: Add more lines if more channel bandwidths are supported.

**h) In case of Smart Antenna Systems:**

- The number of Receive chains: .....
- The number of Transmit chains: .....
  - symmetrical power distribution
  - asymmetrical power distribution

In case of beam forming, the maximum (additional) beam forming gain: ..... dB

NOTE: The additional beam forming gain does not include the basic gain of a single antenna.

**i) Operating Frequency Range(s) of the equipment:**

- Operating Frequency Range 1: 2402 MHz to 2480 MHz
  - Operating Frequency Range 2: ..... MHz to ..... MHz
- NOTE: Add more lines if more Frequency Ranges are supported.

**j) Nominal Channel Bandwidth(s):**

- Nominal Channel Bandwidth 1: 1.17MHz
- Nominal Channel Bandwidth 2: ...../..... MHz

NOTE: Add more lines if more channel bandwidths are supported.

**k) Type of Equipment (stand-alone, combined, plug-in radio device, etc.):**

- Stand-alone
- Combined Equipment (Equipment where the radio part is fully integrated within another type of equipment)
- Plug-in radio device (Equipment intended for a variety of host systems)
- Other

**l) The normal and the extreme operating conditions that apply to the equipment:**

**Normal operating conditions (if applicable):**

Operating temperature: 15°C~35°C

Other (please specify if applicable): .....

**Extreme operating conditions:**

Operating temperature range: Minimum: -10°C Maximum 40°C

Other (please specify if applicable): ..... Minimum: ..... Maximum .....

Details provided are for the:

- stand-alone equipment
- combined (or host) equipment
- test jig



**m) The intended combination(s) of the radio equipment power settings and one or more antenna assemblies and their corresponding e.i.r.p. levels:**

- Antenna Type: PIFA Antenna

Integral Antenna (information to be provided in case of conducted measurements)

Antenna Gain: 1.0 dBi

If applicable, additional beamforming gain (excluding basic antenna gain): ...../..... dB

- Temporary RF connector provided
- No temporary RF connector provided
- Dedicated Antennas (equipment with antenna connector)
- Single power level with corresponding antenna(s)
- Multiple power settings and corresponding antenna(s)

Number of different Power Levels: .....

Power Level 1: ..... dBm

Power Level 2: ..... dBm

Power Level 3: ..... dBm

NOTE 1: Add more lines in case the equipment has more power levels.

NOTE 2: These power levels are conducted power levels (at antenna connector).

- For each of the Power Levels, provide the intended antenna assemblies, their corresponding gains (G) and the resulting e.i.r.p. levels also taking into account the beamforming gain (Y) if applicable

**Power Level 1:** ..... dBm

Number of antenna assemblies provided for this power level: .....

Assembly #	Gain (dBi)	e.i.r.p. (dBm)	Part number or model name
1	1.0	9.81	
2			
3			

NOTE 3: Add more rows in case more antenna assemblies are supported for this power level.

**Power Level 2:** ..... dBm

Number of antenna assemblies provided for this power level: .....

Assembly #	Gain (dBi)	e.i.r.p. (dBm)	Part number or model name
1			
2			
3			

NOTE 4: Add more rows in case more antenna assemblies are supported for this power level.

**Power Level 3:** ..... dBm

Number of antenna assemblies provided for this power level: .....

Assembly #	Gain (dBi)	e.i.r.p. (dBm)	Part number or model name
1			
2			
3			

NOTE 5: Add more rows in case more antenna assemblies are supported for this power level.

**n) The nominal voltages of the stand-alone radio equipment or the nominal voltages of the combined (host) equipment or test jig in case of plug-in devices:**

Details provided are for the:

- stand-alone equipment
- combined (or host) equipment
- test jig

Supply Voltage  AC mains State AC voltage ..... V

DC State DC voltage: DC 3.87V

In case of DC, indicate the type of power source

- Internal Power Supply
- External Power Supply or AC/DC adapter: DC 5V
- Battery: DC 3.87V
- Other: .....

**o) Describe the test modes available which can facilitate testing:**

See clause 1.4

**p) The equipment type (e.g. Bluetooth®, IEEE 802.11™ [i.3], IEEE 802.15.4™ [i.4], proprietary, etc.):**

Bluetooth®

**q) If applicable, the statistical analysis referred to in clause 5.4.1 q)**

(to be provided as separate attachment)

**r) If applicable, the statistical analysis referred to in clause 5.4.1 r)**

(to be provided as separate attachment)

**s) Geo-location capability supported by the equipment:**

- Yes
- The geographical location determined by the equipment as defined in clause 4.3.1.13.2 or clause 4.3.2.12.2 is not accessible to the user
- No

**t) Describe the minimum performance criteria that apply to the equipment (see clause 4.3.1.12.3 or clause 4.3.2.11.3):**

8-DPSK(CH00) =0.87%

### 1.3 TEST CONDITIONS

	Normal Test Conditions	Extreme Test Conditions
Temperature	15°C - 35°C	-10°C ~ 40°C Note: (1)
Relative Humidity	20% - 75%	N/A
Supply Voltage	DC 3.87V	/

**Note:**

- (1) The HT 40°C and LT -10°C was declared by manufacturer, The EUT couldn't be operate normally with higher or lower temperature.
- (2) The measurements are performed at the highest, middle, lowest available channels.

### 1.4 TEST CONFIGURATION OF EUT

Modulation Used For Conformance Testing		
Bluetooth mode	Data rate	Modulation type
BR	1Mbps	GFSK
EDR	2Mbps	$\pi/4$ -DQPSK
EDR	3Mbps	8-DPSK

Test Channel Frequencies Configuration		
Test Channel	EUT Channel	Test Frequency (MHz)
Lowest	CH00	2402
Middle	CH39	2441
Highest	CH78	2480

1.5 DESCRIPTION OF TEST CONDITIONS

**E-1**  
**EUT**

1.6 DESCRIPTION OF SUPPORT UNITS

The EUT has been tested as an independent unit together with other necessary accessories or support units. The following support units or accessories were used to form a representative test configuration during the tests.

Item	Equipment	Model/Type No.	Series No.	Note
E-1	Smart phone	A53 Pro	N/A	EUT

Item	Shielded Type	Ferrite Core	Length	Note

Note:

- (1) The support equipment was authorized by Declaration of Confirmation.
- (2) For detachable type I/O cable should be specified the length in cm in 『Length』 column.

1.7 EQUIPMENTS LIST FOR ALL TEST ITEMS

EQUIPMENT TYPE	Manufacturer	Type No.	Serial No.	Last calibration	Calibrated until	Calibration period
EMI Test Receiver	R&S	ESPI7	101318	2022.04.06	2023.04.05	1 year
Bilog Antenna	TESEQ	CBL6111D	31216	2022.03.30	2023.03.29	1 year
Turn Table	EM	SC100_1	60531	N/A	N/A	N/A
Antenna Mast	EM	SC100	N/A	N/A	N/A	N/A
Horn Antenna	EM	EM-AH-10180	2011071402	2022.03.31	2023.03.30	1 year
Horn Ant	Schwarzbeck	BBHA 9170	9170-181	2022.04.01	2023.03.31	1 year
Test Cable (30MHz-1GHz)	N/A	R-01	N/A	2022.06.17	2025.06.16	3 year
Test Cable (1-18GHz)	N/A	R-02	N/A	2022.06.17	2025.06.16	3 year
50Ω Coaxial Switch	Anritsu	MP59B	6200983705	2020.05.11	2023.05.10	3 year
Pre-Amplifier	EMC	EMC051835SE	980246	2022.06.17	2023.06.16	1 year
Spectrum Analyzer	Agilent	E4407B	MY45108040	2022.04.01	2023.03.31	1 year
Filter	TRILTHIC	2400MHz	29	2020.04.07	2023.04.06	3 year
Attenuator	Weinschel	33-10-33	AR4010	2020.04.07	2023.04.06	3 year
Attenuator	Weinschel	24-20-34	BP4485	2020.04.07	2023.04.06	3 year
MXA Signal Analyzer	Agilent	N9020A	MY49100060	2022.06.17	2023.06.16	1 year
ESG VETCTOR SIGNAL GENERATOR	Agilent	E4438C	MY45093347	2022.04.01	2023.03.31	1 year
Power Splitter	Mini-Circuits/USA	ZN2PD-63-S+	SF025101428	2020.04.07	2023.04.06	3 year
Coupler	Mini-Circuits	ZADC-10-63-S+	SF794101410	2020.04.07	2023.04.06	3 year
Directional Coupler	MCLI/USA	CB11-20	0D2L51502	2020.07.17	2023.07.16	3 year
Attenuator	Agilent	8495B	MY42147029	2020.04.13	2023.04.12	3 year
Power Meter	DARE	RPR3006W	15I00041SNO84	2022.06.17	2023.06.16	1 year
MXG Vector Signal Generator	Agilent	N5182A	MY47070317	2022.06.16	2023.06.15	1 year
Wideband Radio Communication Tester Specifications	R&S	CMW500	148500	2022.06.16	2023.06.15	1 year
temporary antenna connector (Note)	NTS	R001	N/A	N/A	N/A	N/A



## 2. SUMMARY OF TEST RESULTS

The EUT has been tested according to the following specifications:

ETSI EN 300 328 V2.2.2 (2019-07)		
Clause	Test Item	Results
<b>TRANSMITTER PARAMETERS</b>		
4.3.1.2	RF Output Power	Pass
4.3.1.3	Duty cycle, Tx-Sequence, Tx-gap	Not Applicable (See Note 1/2)
4.3.1.4	Accumulated Transmit Time, Frequency Occupation and Hopping Sequence	Pass
4.3.1.5	Hopping Frequency Separation	Pass
4.3.1.6	Medium Utilization (MU) factor	Not Applicable (See Note 1/2)
4.3.1.7	Adaptivity	Not Applicable (See Note 1)
4.3.1.8	Occupied Channel Bandwidth	Pass
4.3.1.9	Transmitter unwanted emission in the OOB domain	Pass
4.3.1.10	Transmitter unwanted emissions in the spurious domain	Pass
<b>RECEIVER PARAMETERS</b>		
4.3.1.11	Receiver Spurious Emissions	Pass
4.3.1.12	Receiver Blocking	Pass

**Note:**

1. These requirements do not apply for equipment with a maximum declared RF output power of less than 10 dBm EIRP or for equipment when operating in a mode where the RF output power is less than 10 dBm EIRP.
2. These requirements apply to non-adaptive frequency hopping equipment or to adaptive frequency hopping equipment operating in a non-adaptive mode
3. The antenna gain provided by customer is used to calculate the EIRP result. NTEK is not responsible for the accuracy of antenna gain parameter.

**2.1 TEST FACILITY**

Shenzhen NTEK Testing Technology Co., Ltd.  
 Add. : 1/F, Building E, Fenda Science Park, Sanwei Community, Xixiang Street, Bao'an District,  
 Shenzhen 518126 P.R. China  
 FCC Registered No.: 463705 IC Registered No.:9270A-1  
 CNAS Registration No.:L5516

**2.2 MAXIMUM MEASUREMENT UNCERTAINTY**

For the test methods, according to ETSI EN 300 328 standard, the measurement uncertainty figures shall be calculated in accordance with ETR 100 028-1[4] and shall correspond to an expansion factor(coverage factor)  $k=1.96$  or  $k=2$  (which provide confidence levels of respectively **95 %** and **95.45 %** in the case where the distributions characterizing the actual measurement uncertainties are normal (Gaussian)).

Maximum measurement uncertainty

No.	Item	Uncertainty
1	Occupied Channel Bandwidth	$\pm 5\%$
2	RF output Power,conducted	$\pm 1.5\text{dB}$
3	Power Spectral Density, conducted	$\pm 3\text{dB}$
4	Unwanted emissions, conducted	$\pm 3\text{dB}$
5	All emissions,radiated	$\pm 6\text{dB}$
6	Temperature	$\pm 3^{\circ}\text{C}$
7	Humidity	$\pm 3\%$
9	Time	$\pm 5\%$

## TRANSMITTER PARAMETERS

### 3. RF OUTPUT POWER

#### 3.1 LIMITS OF RF OUTPUT POWER

Refer to chapter 4.3.1.2.3 of ETSI EN 300 328 V2.2.2 (2019-07)

RF OUTPUT POWER	
Condition	Limit
<input type="checkbox"/> Non-adaptive frequency hopping systems	Equal to or less than the value declared by the supplier. This declared value shall be equal to or less than 20 dBm.
<input checked="" type="checkbox"/> Adaptive frequency hopping systems	equal to or less than 20 dBm.

#### 3.2 TEST PROCEDURE

Refer to chapter 5.4.2.2 of ETSI EN 300 328 V2.2.2 (2019-07)

Measurement	
<input checked="" type="checkbox"/> Conducted measurement	<input type="checkbox"/> Radiated measurement

#### 3.3 DEVIATION FROM TEST STANDARD

No deviation

#### 3.4 TEST SETUP

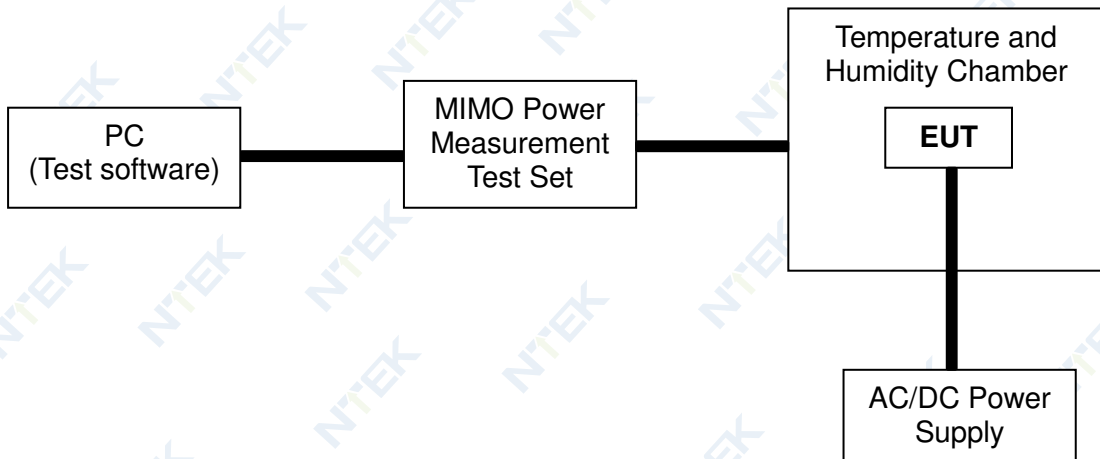

## 3.5 TEST RESULTS

EUT :	Smart phone	Model Name :	A53 Pro
Temperature :	20°C	Relative Humidity :	55 %
Pressure :	1012 hPa	Test Voltage :	DC 3.87V
Test Mode :	BT-GFSK/ $\pi$ /4-DQPSK /8-DPSK		

Test data reference attachment

4. ACCUMULATED TRANSMIT TIME, FREQUENCY OCCUPATION AND HOPPING SEQUENCE

4.1 LIMITS OF ACCUMULATED TRANSMIT TIME, FREQUENCY OCCUPATION AND HOPPING SEQUENCE

Refer to chapter 4.3.1.4.3 of ETSI EN 300 328 V2.2.2 (2019-07)

Accumulated Transmit Time	
Condition	Limit
<input type="checkbox"/> Non-adaptive frequency hopping systems	≤ 15 ms[15 ms * the minimum number of hopping frequencies (N)]
<input checked="" type="checkbox"/> Adaptive frequency hopping systems	≤ 400 ms in [400 ms * the minimum number of hopping frequencies (N)]
MINIMUM FREQUENCY OCCUPATION TIME	
Condition	Limit
<input type="checkbox"/> Non-adaptive frequency hopping systems	Each hopping frequency of the hopping sequence shall be occupied at least once within a period not exceeding four times the product of the dwell time and the number of hopping frequencies in use.
<input checked="" type="checkbox"/> Adaptive frequency hopping systems	
HOPPING SEQUENCE (S)	
Condition	Limit
<input type="checkbox"/> Non-adaptive frequency hopping systems	≥15 hopping frequencies or 15/minimum
<input checked="" type="checkbox"/> Adaptive frequency hopping systems	Operating over a minimum of 70% of the Operating in the band 2.4 GHz to 2.4835 GHz
	≥15 hopping frequencies or 15/minimum

4.2 TEST PROCEDURE

Refer to chapter 5.4.4 of ETSI EN 300 328 V2.2.2 (2019-07)

Measurement	
<input checked="" type="checkbox"/> Conducted measurement	<input type="checkbox"/> Radiated measurement

4.3 DEVIATION FROM TEST STANDARD

No deviation

4.4 TEST SETUP



The measurements only were performed at normal test conditions. The equipment was configured to operate at its maximum Dwell time and maximum Duty Cycle. The measurement was performed on a minimum of 2 hopping frequencies chosen arbitrary from the actual hopping sequence. In case of conducted measurements the transmitter shall be connected to the measuring equipment via a suitable attenuator. Controlling software (Button Function) has been activated to set the EUT on specific status.

4.5 TEST RESULTS

EUT :	Smart phone	Model Name :	A53 Pro
Temperature :	26°C	Relative Humidity	60 %
Pressure :	1012 hPa	Test Voltage :	DC 3.87V
Test Mode :	BT-GFSK/π/4-DQPSK /8-DPSK-Hopping Mode		

Test data reference attachment



5. OCCUPIED CHANNEL BANDWIDTH

5.1 LIMITS OF OCCUPIED CHANNEL BANDWIDTH

Refer to chapter 4.3.1.8.3 of ETSI EN 300 328 V2.2.2 (2019-07)

OCCUPIED CHANNEL BANDWIDTH		
Condition		Limit
All types of equipment		Shall fall completely within the band 2400 to 2483.5 MHz
Additional requirement	For non-adaptive using wide band modulations other than FHSS system and EIRP >10 dBm	Less than 20 MHz
	For non-adaptive frequency hopping system and EIRP >10 dBm	Less than 5 MHz

5.2 TEST PROCEDURE

Refer to chapter 5.4.7.2 of ETSI EN 300 328 V2.2.2 (2019-07)

Measurement	
<input checked="" type="checkbox"/> Conducted measurement	<input type="checkbox"/> Radiated measurement

The setting of the Spectrum Analyzer

Center Frequency	The centre frequency of the channel under test
Frequency Span	2 × Nominal Channel Bandwidth
Detector	RMS
RBW	~ 1 % of the span without going below 1 %
VBW	3 × RBW
Trace	Max hold
Sweep time	1s

5.3 DEVIATION FROM TEST STANDARD

No deviation

5.4 TEST SETUP



These measurements only were performed at normal test conditions. The measurement shall be performed only on the lowest and the highest frequency within the ststed frequency range. Using software to force the EUT to hop or transmit on a single Hopping frequency. In case of conducted measurements the transmitter shall be connected to the measuring equipment via a suitable attenuator. Controlling software (Button Function) has been activated to set the EUT on specific status.

5.5 TEST RESULTS

EUT :	Smart phone	Model Name :	A53 Pro
Temperature :	26°C	Relative Humidity :	60 %
Pressure :	1012 hPa	Test Voltage :	DC 3.87V
Test Mode :	BT-GFSK/π/4-DQPSK /8-DPSK-(CH00/CH78)		

Test data reference attachment

6. TRANSMITTER UNWANTED EMISSIONS IN THE OUT-OF-BAND DOMAIN

6.1 LIMITS OF TRANSMITTER UNWANTED EMISSIONS IN THE OUT-OF-BAND DOMAIN  
Refer to chapter 4.3.1.9.3 of ETSI EN 300 328 V2.2.2 (2019-07)

TRANSMITTER UNWANTED EMISSIONS IN THE OUT-OF-BAND DOMAIN	
Condition	Limit
Under all test conditions	The transmitter unwanted emissions in the out-of-band domain but outside the allocated band, shall not exceed the values provided by the mask in below figure.

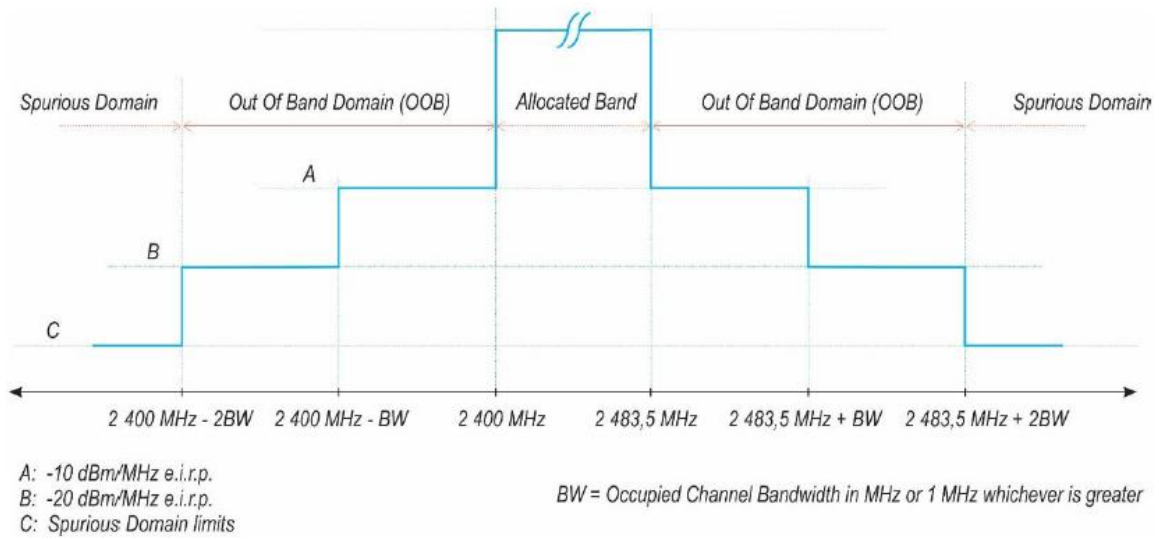

Figure 1: Transmit mask

6.2 TEST PROCEDURE

Refer to chapter 5.4.8.2 of ETSI EN 300 328 V2.2.2 (2019-07)

Measurement	
<input checked="" type="checkbox"/> Conducted measurement	<input type="checkbox"/> Radiated measurement

The setting of the Spectrum Analyzer

Span	0Hz
Filter Mode	Channel Filter
Trace Mode	Clear/Write
Trigger Mode	Video Trigger
Detector	RMS
Sweep Point / Sweep Mode	5000 / Continuous
RBW / VBW	1MHz / 3MHz

6.3 DEVIATION FROM TEST STANDARD

No deviation

6.4 TEST SETUP

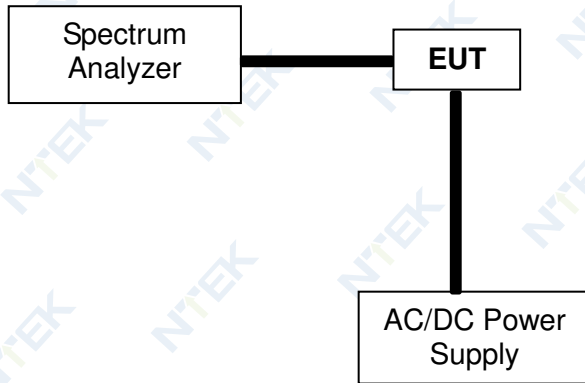

According to the ETSI EN 300328 V2.2.2 clause 5.4.8.1: These measurements shall only be performed at normal test conditions. For equipment using FHSS modulation, the measurements shall be performed during normal operation (hopping).

For equipment using wide band modulations other than FHSS, the measurement shall be performed at the lowest and the highest channel on which the equipment can operate. These operating channels shall be recorded.

The equipment shall be configured to operate under its worst case situation with respect to output power.

If the equipment can operate with different Nominal Channel Bandwidths (e.g. 20 MHz and 40 MHz), then each channel bandwidth shall be tested separately.

6.5 TEST RESULTS

EUT :	Smart phone	Model Name :	A53 Pro
Temperature :	26°C	Relative Humidity :	60 %
Pressure :	1012 hPa	Test Voltage :	DC 3.87V
Test Mode :	BT-GFSK/π/4-DQPSK /8-DPSK-(CH78)		

Test data reference attachment

**7. HOPPING FREQUENCY SEPARATION**

**7.1 LIMITS OF HOPPING FREQUENCY SEPARATION**

Refer to chapter 4.3.1.5.3 of ETSI EN 300 328 V2.2.2 (2019-07)

HOPPING FREQUENCY SEPARATION	
Condition	Limit
<input type="checkbox"/> Non-adaptive frequency hopping systems	The minimum Hopping Frequency Separation shall be equal to or greater than occupied channel bandwidth of a single hop, with a minimum separation of 100 kHz.
<input checked="" type="checkbox"/> Adaptive frequency hopping systems	The minimum Hopping Frequency Separation shall be 100 kHz.

**7.2 TEST PROCEDURE**

Refer to chapter 5.4.5.2 of ETSI EN 300 328 V2.2.2 (2019-07)

Measurement	
<input checked="" type="checkbox"/> Conducted measurement	<input type="checkbox"/> Radiated measurement

**The setting of the Spectrum Analyzer**

Center Frequency	Centre of the two adjacent hopping frequencies
Frequency Span	Sufficient to see the complete power envelope of both hopping frequencies
Detector	Max Peak
RBW	~ 1 % of the span
VBW	3 × RBW
Trace	Max hold
Sweep Time	Auto

**7.3 DEVIATION FROM TEST STANDARD**

No deviation

7.4 TEST SETUP



The measurements were performed at normal test conditions. The measurement was performed on 2 adjacent hopping frequencies. In case of conducted measurements the transmitter shall be connected to the measuring equipment via a suitable attenuator. Controlling software (Button Function) has been activated to set the EUT on specific status.

7.5 TEST RESULTS

EUT :	Smart phone	Model Name :	A53 Pro
Temperature :	26°C	Relative Humidity :	60 %
Pressure :	1012 hPa	Test Voltage :	DC 3.87V
Test Mode :	BT-GFSK/π/4-DQPSK /8-DPSK-(CH00/CH39/CH78)		

Test data reference attachment

- Note: 1.The limitation is from OCB of a single hop and this value must greater and equal to 100kHz.  
 2.The device will never “hop” to its neighbour channel, therefore the “effective” channel separation becomes 2x the “normal” channel separation.



**8. TRANSMITTER UNWANTED EMISSIONS IN THE SPURIOUS DOMAIN**

**8.1 LIMITS OF TRANSMITTER TRANSMITTER UNWANTED EMISSIONS IN THE SPURIOUS DOMAIN**

Refer to chapter 4.3.1.10.3 of ETSI EN 300 328 V2.2.2 (2019-07)

TRANSMITTER UNWANTED EMISSIONS IN THE SPURIOUS DOMAIN		
Frequency Range	Maximum Power Limit (E.R.P.(≤1 GHz) E.I.R.P.(> 1 GHz))	Bandwidth
30 MHz to 47 MHz	-36dBm	100 kHz
47 MHz to 74 MHz	-54dBm	100 kHz
74 MHz to 87.5 MHz	-36dBm	100 kHz
87.5 MHz to 118 MHz	-54dBm	100 kHz
118 MHz to 174 MHz	-36dBm	100 kHz
174 MHz to 230 MHz	-54dBm	100 kHz
230 MHz to 470 MHz	-36dBm	100 kHz
470 MHz to 694 MHz	-54dBm	100 kHz
694 MHz to 1 GHz	-36dBm	100 kHz
1 GHz ~ 12.75 GHz	-30dBm	1 MHz

**8.2 TEST PROCEDURE**

Refer to chapter 5.4.9.2 of ETSI EN 300 328 V2.2.2 (2019-07)

Measurement	
<input checked="" type="checkbox"/> Conducted measurement	<input checked="" type="checkbox"/> Radiated measurement

The setting of the Spectrum Analyzer

RBW	100K(<1GHz) / 1M(>1GHz)
VBW	300K(<1GHz) / 3M(>1GHz)

**8.3 DEVIATION FROM TEST STANDARD**

No deviation

### 8.4 TEST SETUP

Radiated measurement:

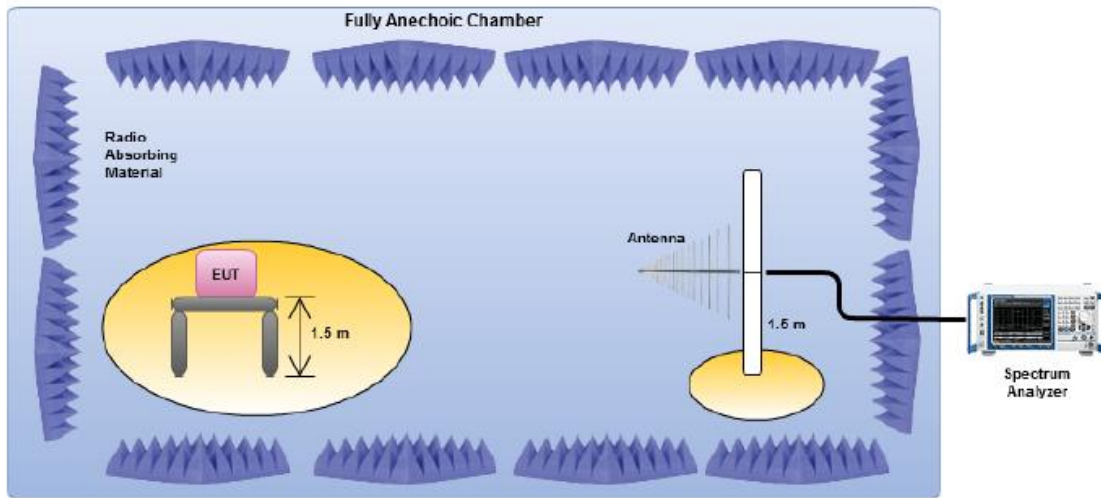

Conducted measurement:



1. For the actual test configuration, please refer to the related Item in this test report (Photographs of the Test Configuration ).
2. The measurements were performed when normal hopping was disabled. In this case measurements were performed when operating at the lowest and the highest hopping frequency.
3. The equipment was configured to operate under its worst case situation with respect to output power.
4. The test setup has been constructed as the normal use condition. Controlling software (Button Function) has been activated to set the EUT on specific status.

8.5 TEST RESULTS (Radiated measurement)  
BELOW 1 GHz WORST- CASE DATA (30 MHz ~ 1GHz)

EUT :	Smart phone	Model Name :	A53 Pro
Temperature :	24 °C	Relative Humidity	54%
Pressure :	1010 hPa	Test Power :	DC 3.87V
Test Mode :	BT-GFSK (CH00)		

Polar (H/V)	Frequency	Meter Reading	Factor	Emission Level	Limits	Margin	Remark
	(MHz)	(dBm)	(dB)	(dBm)	(dBm)	(dB)	
V	38.64	-85.80	15.77	-70.03	-36	-34.03	peak
V	106.866	-87.40	16.26	-71.14	-54	-17.14	peak
V	189.796	-79.00	16.22	-62.78	-36	-26.78	peak
V	376.184	-81.60	16.19	-65.41	-54	-11.41	peak
V	584.778	-86.40	14.53	-71.87	-36	-35.87	peak
V	701.843	-82.30	16.03	-66.27	-36	-30.27	peak
H	35.448	-77.00	15.45	-61.55	-54	-7.55	peak
H	113.414	-78.90	15.20	-63.70	-54	-9.70	peak
H	225.705	-77.20	15.83	-61.37	-36	-25.37	peak
H	462.705	-84.10	16.11	-67.99	-54	-13.99	peak
H	427.317	-83.40	17.36	-66.04	-36	-30.04	peak
H	831.444	-84.50	16.03	-68.47	-36	-32.47	peak

**Remark:**

1. Emission Level= Meter Reading+ Factor, Margin= Limit- Emission Level.
2. All the modes had been tested, but only the worst data recorded in the report.

ABOVE 1 GHz WORST- CASE DATA (1GHz ~ 12.75GHz)

EUT :	Smart phone	Model Name :	A53 Pro
Temperature :	24 °C	Relative Humidity	54%
Pressure :	1010 hPa	Test Power :	DC 3.87V
Test Mode :	GFSK (CH00/CH39/CH78)		

Polar (H/V)	Frequency	Meter Reading	Factor	Emission Level	Limits	Margin	Remark
	(MHz)	(dBm)	(dB)	(dBm)	(dBm)	(dB)	
<b>operation frequency:2402</b>							
V	4804.57	-75.80	25.63	-50.17	-30	-20.17	peak
V	7206.87	-72.00	29.83	-42.17	-30	-12.17	peak
H	4804.57	-73.40	25.63	-47.77	-30	-17.77	peak
H	7206.87	-70.10	29.83	-40.27	-30	-10.27	peak
<b>operation frequency:2441</b>							
V	4882.42	-69.80	26.62	-43.18	-30	-13.18	peak
V	7324.12	-77.30	29.64	-47.66	-30	-17.66	peak
H	4882.42	-70.60	26.62	-43.98	-30	-13.98	peak
H	7324.12	-72.80	29.64	-43.16	-30	-13.16	peak
<b>operation frequency:2480</b>							
V	4961.02	-71.10	27.49	-43.61	-30	-13.61	peak
V	7440.33	-79.00	29.82	-49.18	-30	-19.18	peak
H	4961.02	-65.80	27.49	-38.31	-30	-8.31	peak
H	7440.33	-77.10	29.82	-47.28	-30	-17.28	peak
<b>Remark:</b>							
1. Emission Level= Meter Reading+ Factor, Margin= Limit- Emission Level.							
2. All the modes had been tested, but only the worst data recorded in the report.							

8.6 TEST RESULTS (Conducted measurement)

Test data reference attachment

**9. RECEIVER SPURIOUS EMISSIONS**

**9.1 LIMITS OF RECEIVER SPURIOUS RADIATION**

Refer to chapter 4.3.1.11.3 of ETSI EN 300 328 V2.2.2 (2019-07)

RECEIVER SPURIOUS EMISSIONS		
Frequency Range	Maximum Power Limit (E.R.P.(≤1 GHz) E.I.R.P.(> 1 GHz))	Measurement Bandwidth
30 MHz ~ 1 GHz	-57dBm	100KHz
1 GHz ~ 12.75 GHz	-47dBm	1MHz

**9.2 TEST PROCEDURE**

Refer to chapter 5.4.10.2 of ETSI EN 300 328 V2.2.2 (2019-07)

Measurement	
<input checked="" type="checkbox"/> Conducted measurement	<input checked="" type="checkbox"/> Radiated measurement

The setting of the Spectrum Analyzer

RBW	100K(<1GHz) / 1M(>1GHz)
VBW	300K(<1GHz) / 3M(>1GHz)

**9.3 DEVIATION FROM TEST STANDARD**

No deviation

### 9.4 TEST SETUP

Radiated measurement:

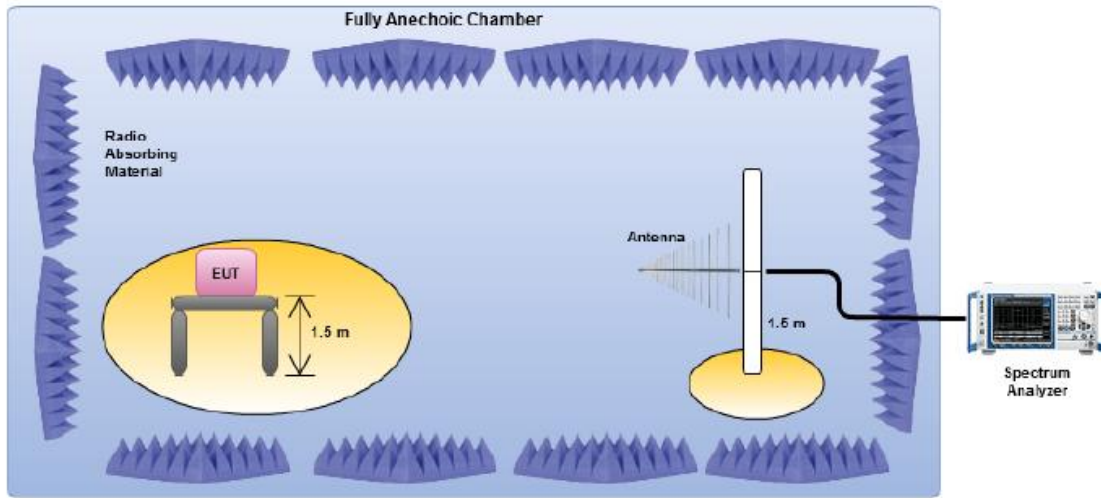

Conducted measurement:

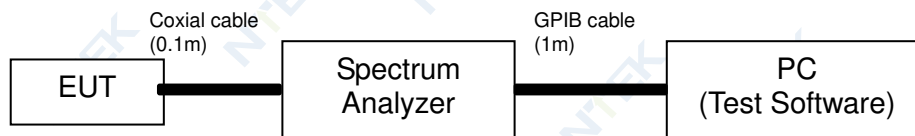

1. For the actual test configuration, please refer to the related Item in this test report (Photographs of the Test Configuration ).
2. Testing was performed when the equipment was in a receive-only mode.
3. The measurements were performed when normal hopping was disabled. In this case measurements were performed when operating at the lowest and the highest hopping frequency.
4. The test setup has been constructed as the normal use condition. Controlling software (Button Function) has been activated to set the EUT on specific status.



9.5 TEST RESULTS (Radiated measurement)

RX BELOW 1 GHz WORST- CASE DATA (30 MHz ~ 1GHz)

EUT :	Smart phone	Model Name :	A53 Pro
Temperature :	24 °C	Relative Humidity	54%
Pressure :	1010 hPa	Test Power :	DC 3.87V
Test Mode :	GFSK(CH00)		

Polar (H/V)	Frequency	Meter Reading	Factor	Emission Level	Limits	Margin	Remark
	(MHz)	(dBm)	(dB)	(dBm)	(dBm)	(dB)	
V	34.5	-84.46	11.98	-72.48	-57	-15.48	peak
V	108.075	-79.01	12.67	-66.34	-57	-9.34	peak
V	183.966	-87.21	13.94	-73.27	-57	-16.27	peak
V	376.468	-80.55	14.65	-65.90	-57	-8.90	peak
V	551.875	-83.13	16.25	-66.88	-57	-9.88	peak
V	753.153	-84.76	14.45	-70.31	-57	-13.31	peak
H	43.423	-86.98	13.60	-73.38	-57	-16.38	peak
H	114.297	-85.77	15.11	-70.66	-57	-13.66	peak
H	193.861	-87.09	13.30	-73.79	-57	-16.79	peak
H	348.473	-80.79	18.00	-62.79	-57	-5.79	peak
H	650.078	-83.40	16.63	-66.77	-57	-9.77	peak
H	709.236	-85.79	17.63	-68.16	-57	-11.16	peak

**Remark:**

1. Emission Level= Meter Reading+ Factor, Margin= Limit- Emission Level.
2. All the modes had been tested, but only the worst data recorded in the report.



RX ABOVE 1 GHz WORST- CASE DATA (1GHz ~ 12.75GHz)

EUT :	Smart phone	Model Name :	A53 Pro
Temperature :	24 °C	Relative Humidity	54%
Pressure :	1010 hPa	Test Power :	DC 3.87V
Test Mode :	GFSK (CH00)		

Polar (H/V)	Frequency	Meter Reading	Factor	Emission Level	Limits	Margin	Remark
	(MHz)	(dBm)	(dB)	(dBm)	(dBm)	(dB)	
V	1111.65	-87.25	18.94	-68.31	-47	-21.31	peak
V	2585.03	-91.44	18.82	-72.62	-47	-25.62	peak
V	3252.66	-93.54	19.02	-74.52	-47	-27.52	peak
V	4298.22	-92.81	25.13	-67.68	-47	-20.68	peak
V	4559.57	-93.66	25.16	-68.50	-47	-21.50	peak
V	5777.72	-87.63	25.19	-62.44	-47	-15.44	peak
H	2800.65	-87.95	19.11	-68.84	-47	-21.84	peak
H	2530.03	-94.12	19.68	-74.44	-47	-27.44	peak
H	3449.61	-91.78	19.21	-72.57	-47	-25.57	peak
H	3802.37	-94.28	20.23	-74.05	-47	-27.05	peak
H	4264.03	-94.18	17.6	-76.58	-47	-29.58	peak
H	5276.46	-88.07	23.56	-64.51	-47	-17.51	peak

1. Emission Level= Meter Reading+ Factor, Margin= Limit- Emission Level.
2. All the modes had been tested, but only the worst data recorded in the report.

9.6 TEST RESULTS (Conducted measurement)

Test data reference attachment

**10. RECEIVER BLOCKING**

**10.1 PERFORMANCE CRITERIA**

The minimum performance criterion shall be a PER less than or equal to 10 %. The manufacturer may declare alternative performance criteria as long as that is appropriate for the intended use of the equipment (see clause 5.4.1.t)).

**10.2 LIMITS OF RECEIVER BLOCKING**

While maintaining the minimum performance criteria as defined in clause 4.3.1.12.3, the blocking levels at specified frequency offsets shall be equal to or greater than the limits defined for the applicable receiver category provided in table 6, table 7 or table 8.

**Table 6: Receiver Blocking parameters for Receiver Category 1 equipment**

Wanted signal mean power from companion device (dBm) (see notes 1 and 4)	Blocking signal Frequency (MHz)	Blocking signal power (dBm) (see note 4)	Type of blocking signal
(-133 dBm + 10 × log <sub>10</sub> (OCBW)) or -68 dBm whichever is less (see note 2)	2 380	-34	CW
	2 504		
(-139 dBm + 10 × log <sub>10</sub> (OCBW)) or -74 dBm whichever is less (see note 3)	2 300		
	2 330		
	2 360		
	2524		
	2584		
	2674		

NOTE 1: OCBW is in Hz.

NOTE 2: In case of radiated measurements using a companion device and the level of the wanted signal from the companion device cannot be determined, a relative test may be performed using a wanted signal up to P<sub>min</sub> + 26 dB where P<sub>min</sub> is the minimum level of wanted signal required to meet the minimum performance criteria as defined in clause 4.3.1.12.3 in the absence of any blocking signal.

NOTE 3: In case of radiated measurements using a companion device and the level of the wanted signal from the companion device cannot be determined, a relative test may be performed using a wanted signal up to P<sub>min</sub> + 20 dB where P<sub>min</sub> is the minimum level of wanted signal required to meet the minimum performance criteria as defined in clause 4.3.1.12.3 in the absence of any blocking signal.

NOTE 4: The level specified is the level at the UUT receiver input assuming a 0 dBi antenna assembly gain. In case of conducted measurements, this level has to be corrected for the (in-band) antenna assembly gain (G). In case of radiated measurements, this level is equivalent to a power flux density (PFD) in front of the UUT antenna with the UUT being configured/positioned as recorded in clause 5.4.3.2.2.

**Table 7: Receiver Blocking parameters receiver category 2 equipment**

Wanted signal mean power from companion device (dBm) (see notes 1 and 3)	Blocking signal Frequency (MHz)	Blocking signal power (dBm) (see note 3)	Type of blocking signal
(-139 dBm + 10 × log <sub>10</sub> (OCBW) + 10 dB) or (-74 dBm + 10 dB) whichever is less (see note 2)	2 380	-34	CW
	2 504		
	2 300		
	2 584		

NOTE 1: OCBW is in Hz.

NOTE 2: In case of radiated measurements using a companion device and the level of the wanted signal from the companion device cannot be determined, a relative test may be performed using a wanted signal up to P<sub>min</sub> + 26 dB where P<sub>min</sub> is the minimum level of wanted signal required to meet the minimum performance criteria as defined in clause 4.3.1.12.3 in the absence of any blocking signal.

NOTE 3: The level specified is the level at the UUT receiver input assuming a 0 dBi antenna assembly gain. In case of conducted measurements, this level has to be corrected for the (in-band) antenna assembly gain (G). In case of radiated measurements, this level is equivalent to a power flux density (PFD) in front of the UUT antenna with the UUT being configured/positioned as recorded in clause 5.4.3.2.2.

**Table 8: Receiver Blocking parameters receiver category 3 equipment**

Wanted signal mean power from companion device (dBm)	Blocking signal Frequency (MHz)	Blocking signal power (dBm) (see note 2)	Type of blocking signal
(-139 dBm + 10 × log <sub>10</sub> (OCBW) + 20 dB) or (-74 dBm + 20 dB) whichever is less (see note 2)	2 380	-34	CW
	2 504		
	2 300		
	2 584		

NOTE 1: OCBW is in Hz.

NOTE 2: In case of radiated measurements using a companion device and the level of the wanted signal from the companion device cannot be determined, a relative the test may be performed using a wanted signal up to P<sub>min</sub> + 30 dB where P<sub>min</sub> is the minimum level of wanted signal required to meet the minimum performance criteria as defined in clause 4.3.1.12.3 in the absence of any blocking signal.

NOTE 3: The level specified is the level at the UUT receiver input assuming a 0 dBi antenna assembly gain. In case of conducted measurements, this level has to be corrected for the (in-band) antenna assembly gain (G). In case of radiated measurements, this level is equivalent to a power flux density (PFD) in front of the UUT antenna with the UUT being configured/positioned as recorded in clause 5.4.3.2.2.

### 10.3 TEST PROCEDURE

Refer to chapter 5.4.11.2 of ETSI EN 300 328 V2.2.2 (2019-07)

Measurement	
<input checked="" type="checkbox"/> Conducted measurement	<input type="checkbox"/> Radiated measurement

10.4 DEVIATION FROM TEST STANDARD

No deviation

10.5 TEST SETUP

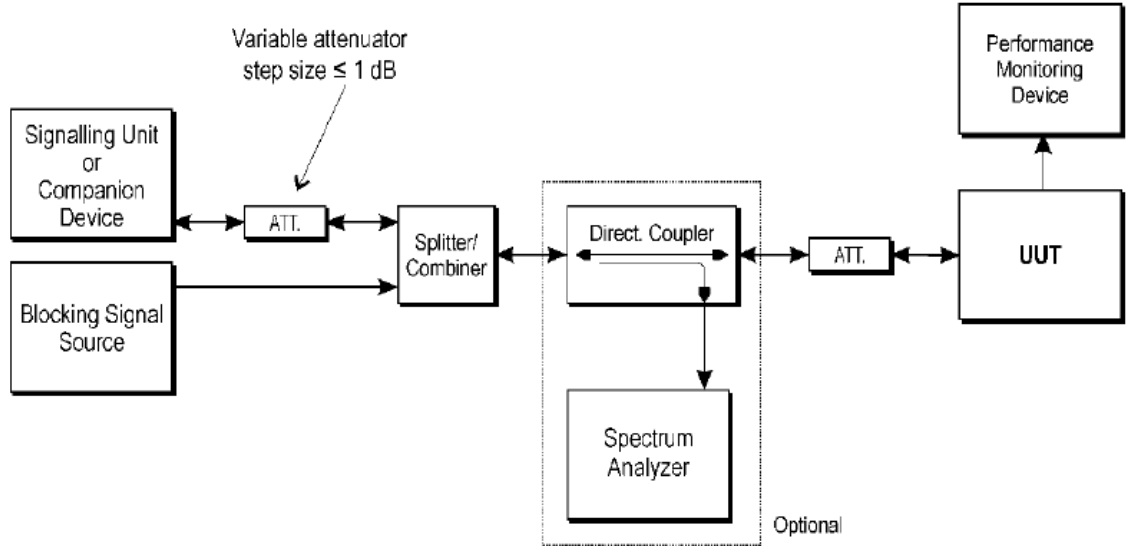

10.6 TEST RESULTS

EUT :	Smart phone	Model Name :	A53 Pro
Temperature :	24 °C	Relative Humidity	54%
Pressure :	1010 hPa	Test Power :	DC 3.87V
Test Mode :	GFSK Hopping mode (RX)		

CH00

receiver category 2

Wanted signal mean power from companion device (dBm) (see notes 1 and 3)	Blocking signal Frequency (MHz)	Blocking signal power(dBm) (see note 3)	PER %	PER Limit %
-70.17	2 380	-34	0.76%	≤10
	2 504		0.67%	
	2 300		0.17%	≤10
	2 584		0.72%	

CH78

receiver category 2

Wanted signal mean power from companion device (dBm) (see notes 1 and 3)	Blocking signal Frequency (MHz)	Blocking signal power(dBm) (see note 3)	PER %	PER Limit %
-70.15	2 380	-34	0.06%	≤10
	2 504		0.45%	
	2 300		0.09%	≤10
	2 584		0.73%	

Note: (1) The above results were obtained from laboratory tests.

EUT :	Smart phone	Model Name :	A53 Pro
Temperature :	24 °C	Relative Humidity	54%
Pressure :	1010 hPa	Test Power :	DC 3.87V
Test Mode :	π/4 DQPSK Hopping mode (RX)		

CH00

receiver category 2

Wanted signal mean power from companion device (dBm) (see notes 1 and 3)	Blocking signal Frequency (MHz)	Blocking signal power(dBm) (see note 3)	PER %	PER Limit %
-68.32	2 380	-34	0.15%	≤10
	2 504		0.03%	
	2 300		0.25%	≤10
	2 584		0.59%	

CH78

receiver category 2

Wanted signal mean power from companion device (dBm) (see notes 1 and 3)	Blocking signal Frequency (MHz)	Blocking signal power(dBm) (see note 3)	PER %	PER Limit %
-68.32	2 380	-34	0.23%	≤10
	2 504		0.64%	
	2 300		0.68%	≤10
	2 584		0.57%	

Note: (1) The above results were obtained from laboratory tests.

EUT :	Smart phone	Model Name :	A53 Pro
Temperature :	24 °C	Relative Humidity	54%
Pressure :	1010 hPa	Test Power :	DC 3.87V
Test Mode :	8-DPSK Hopping mode (RX)		

CH00

receiver category 2

Wanted signal mean power from companion device (dBm) (see notes 1 and 3)	Blocking signal Frequency (MHz)	Blocking signal power(dBm) (see note 3)	PER %	PER Limit %
-68.32	2 380	-34	0.57%	≤10
	2 504		0.30%	
	2 300		0.87%	≤10
	2 584		0.26%	

CH78

receiver category 2

Wanted signal mean power from companion device (dBm) (see notes 1 and 3)	Blocking signal Frequency (MHz)	Blocking signal power(dBm) (see note 3)	PER %	PER Limit %
-68.34	2 380	-34	0.40%	≤10
	2 504		0.77%	
	2 300		0.14%	≤10
	2 584		0.51%	

Note: (1) The above results were obtained from laboratory tests.



## 11. TEST RESULTS

### 11.1 Accumulated Transmit Time

Condition	Mode	Frequency (MHz)	Antenna	Accumulated Transmit Time (ms)	Limit (ms)	Sweep Time (ms)	Burst Number	Verdict
NVNT	1-DH1	2402	Ant1	120.582	400	31600	319	Pass
NVNT	1-DH1	2480	Ant1	120.582	400	31600	319	Pass
NVNT	1-DH3	2402	Ant1	276.146	400	31600	169	Pass
NVNT	1-DH3	2480	Ant1	245.1	400	31600	150	Pass
NVNT	1-DH5	2402	Ant1	302.61	400	31600	105	Pass
NVNT	1-DH5	2480	Ant1	288	400	31600	100	Pass
NVNT	2-DH1	2402	Ant1	122.815	400	31600	319	Pass
NVNT	2-DH1	2480	Ant1	122.815	400	31600	319	Pass
NVNT	2-DH3	2402	Ant1	269.94	400	31600	165	Pass
NVNT	2-DH3	2480	Ant1	251.944	400	31600	154	Pass
NVNT	2-DH5	2402	Ant1	305.81	400	31600	106	Pass
NVNT	2-DH5	2480	Ant1	302.82	400	31600	105	Pass
NVNT	3-DH1	2402	Ant1	123.134	400	31600	319	Pass
NVNT	3-DH1	2480	Ant1	120.432	400	31600	312	Pass
NVNT	3-DH3	2402	Ant1	266.668	400	31600	163	Pass
NVNT	3-DH3	2480	Ant1	243.764	400	31600	149	Pass
NVNT	3-DH5	2402	Ant1	297.361	400	31600	103	Pass
NVNT	3-DH5	2480	Ant1	357.864	400	31600	124	Pass

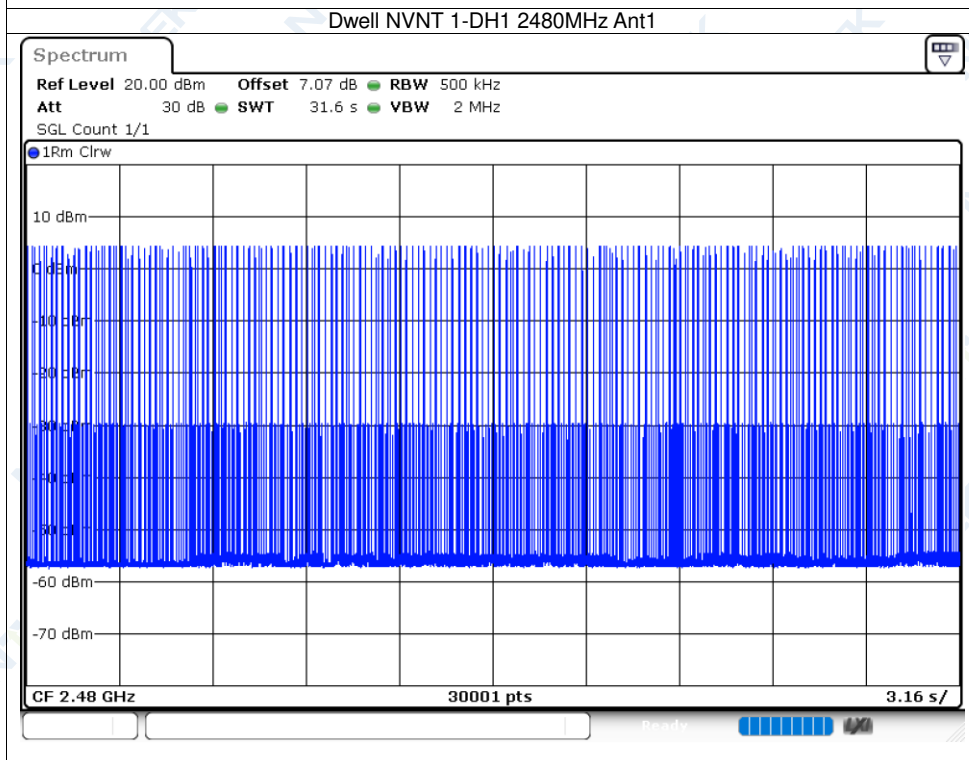
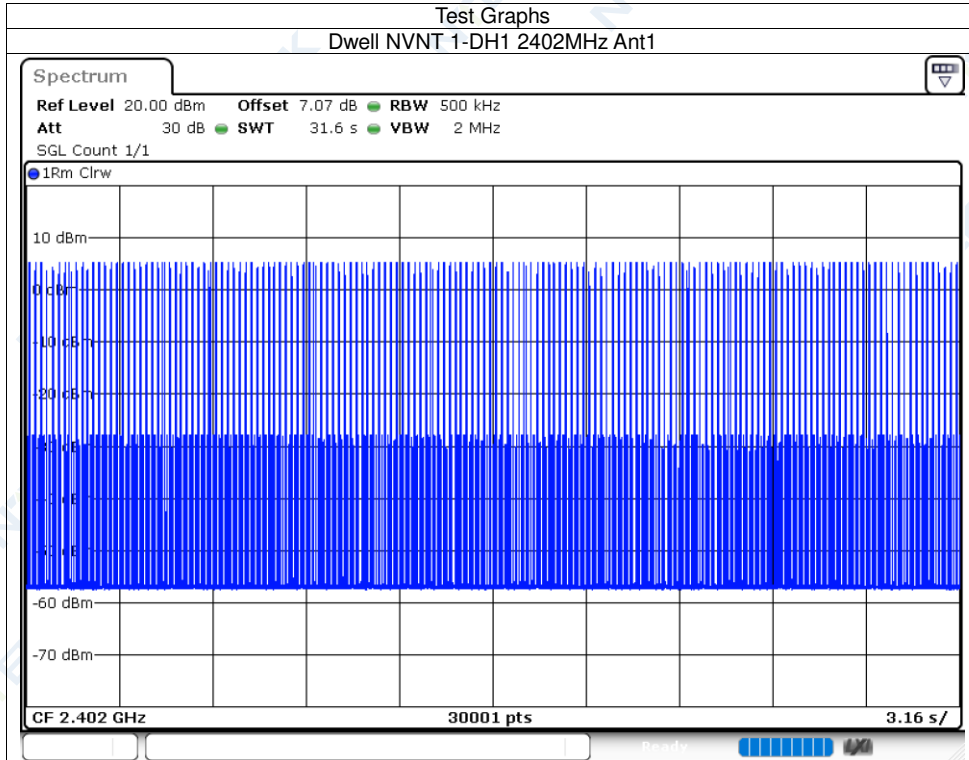

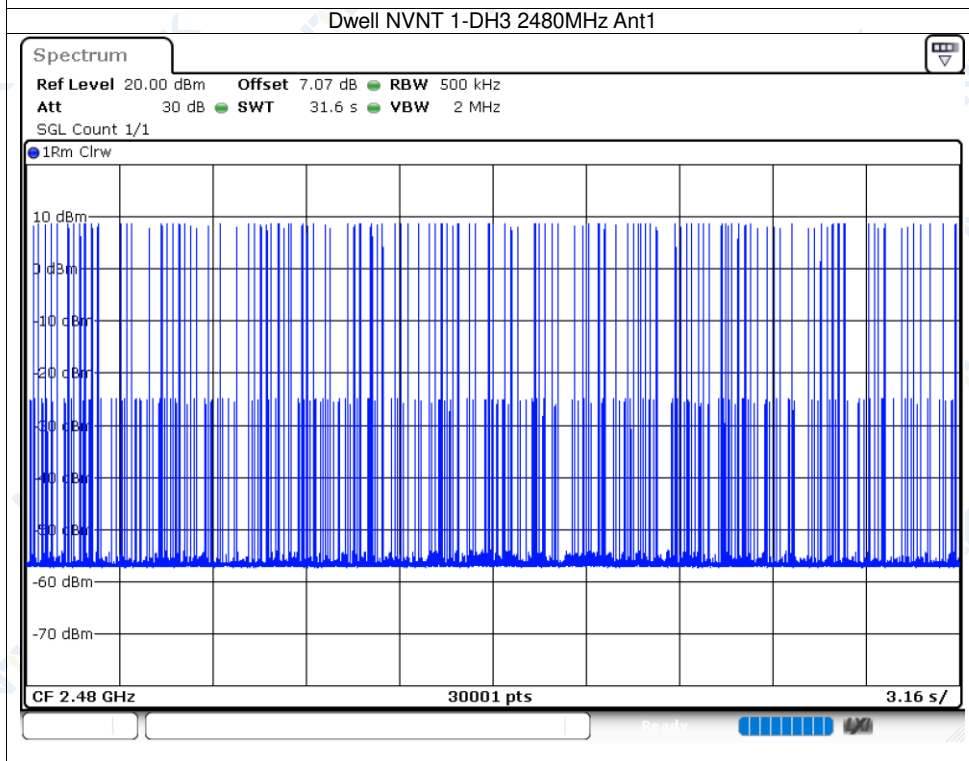
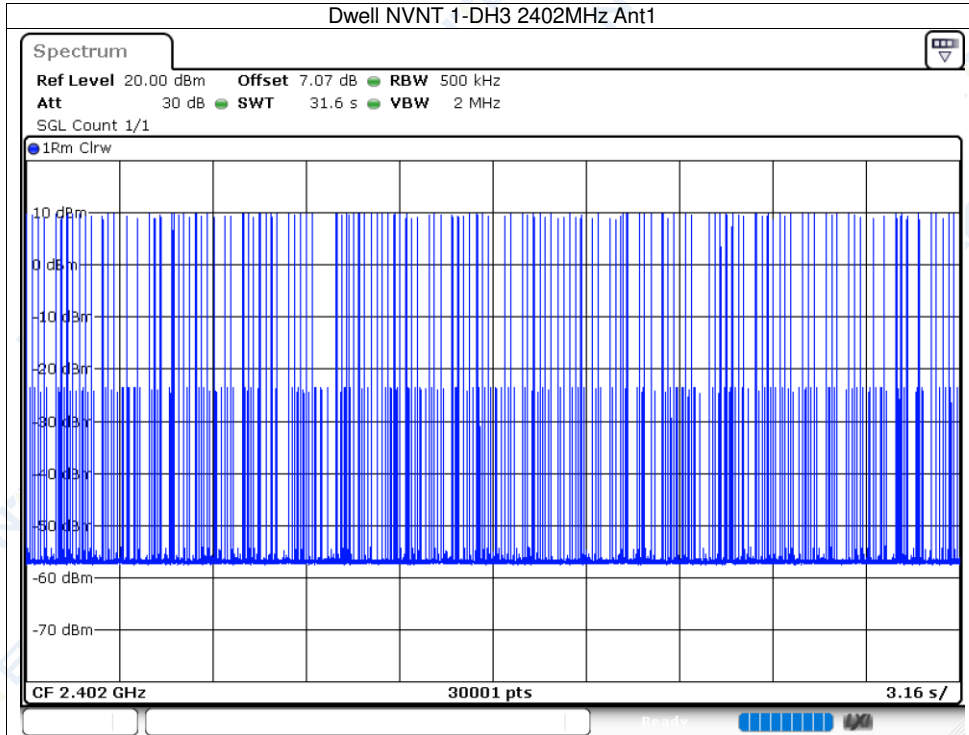

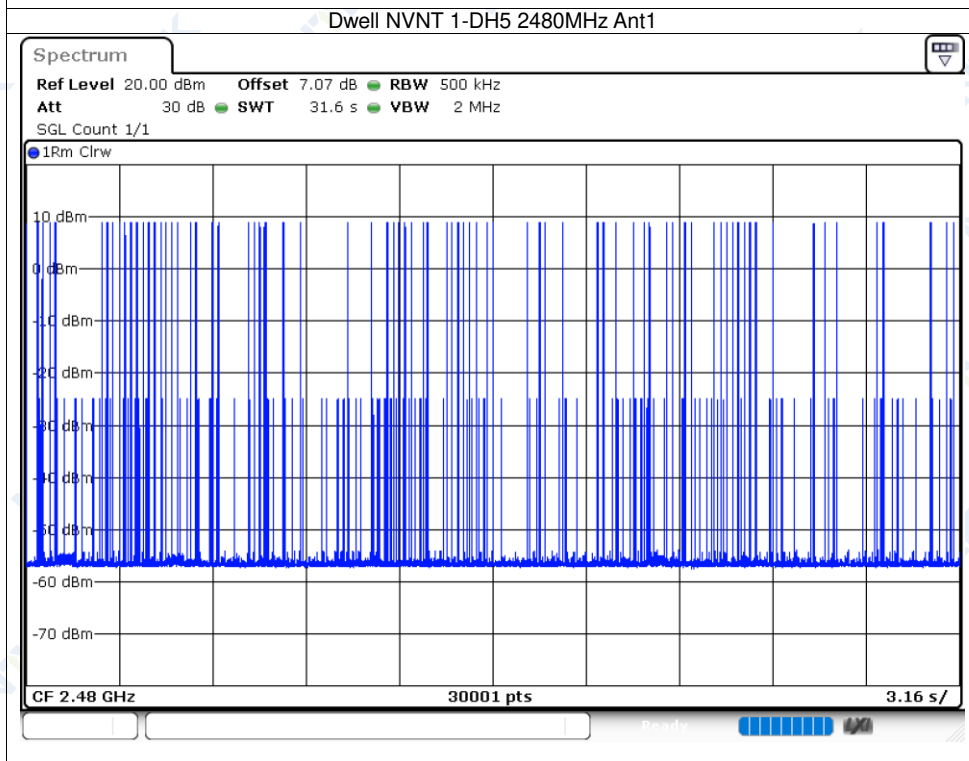
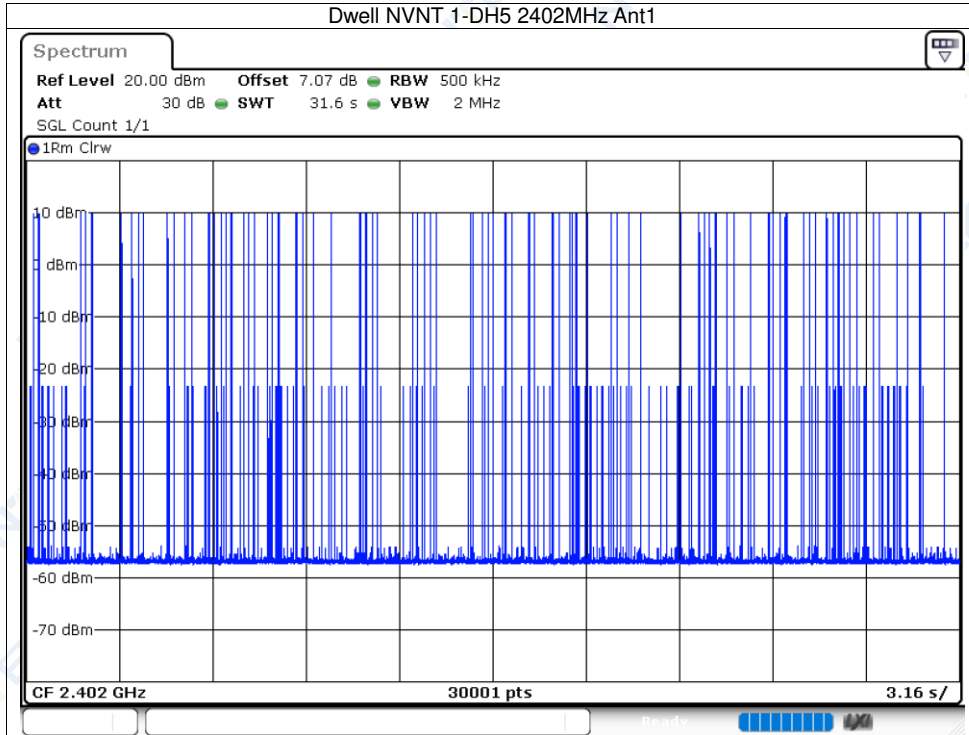

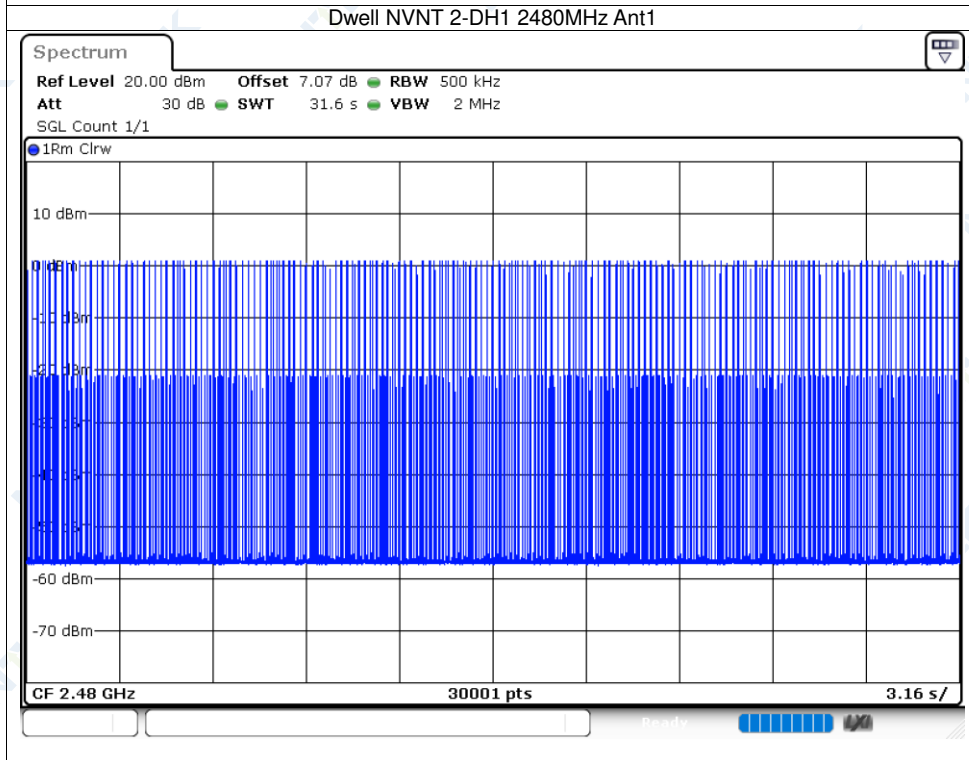
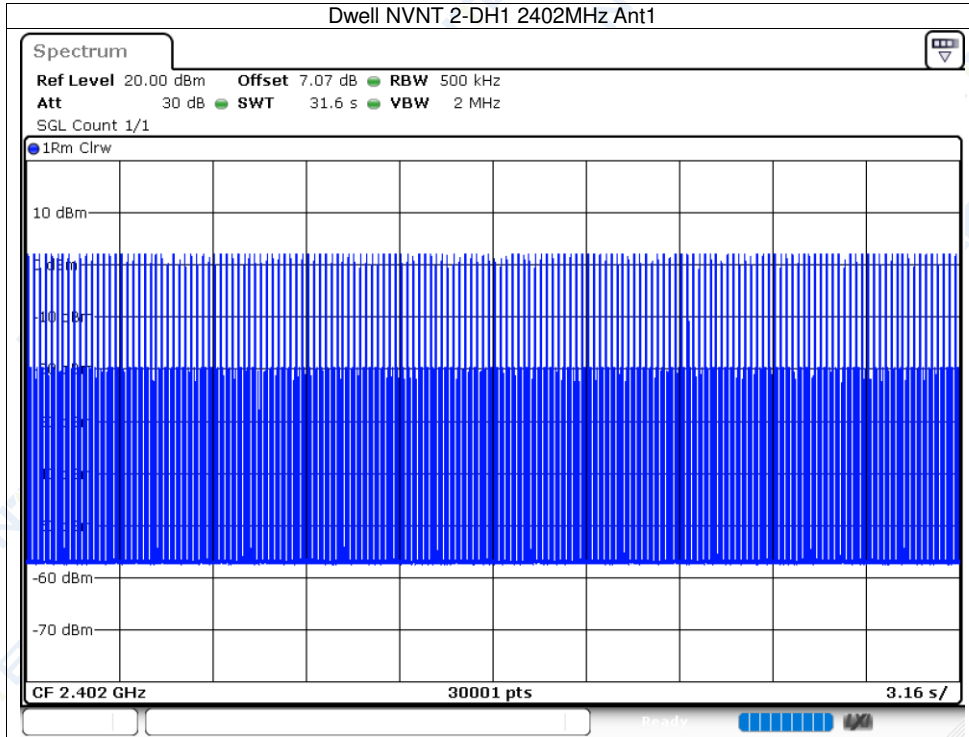

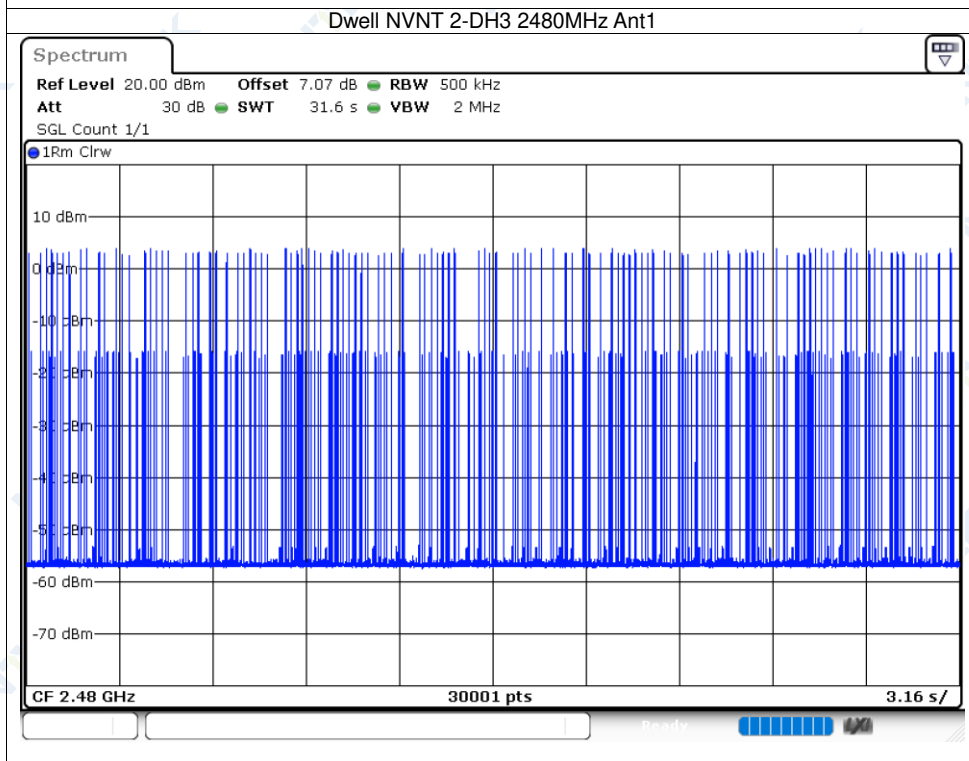
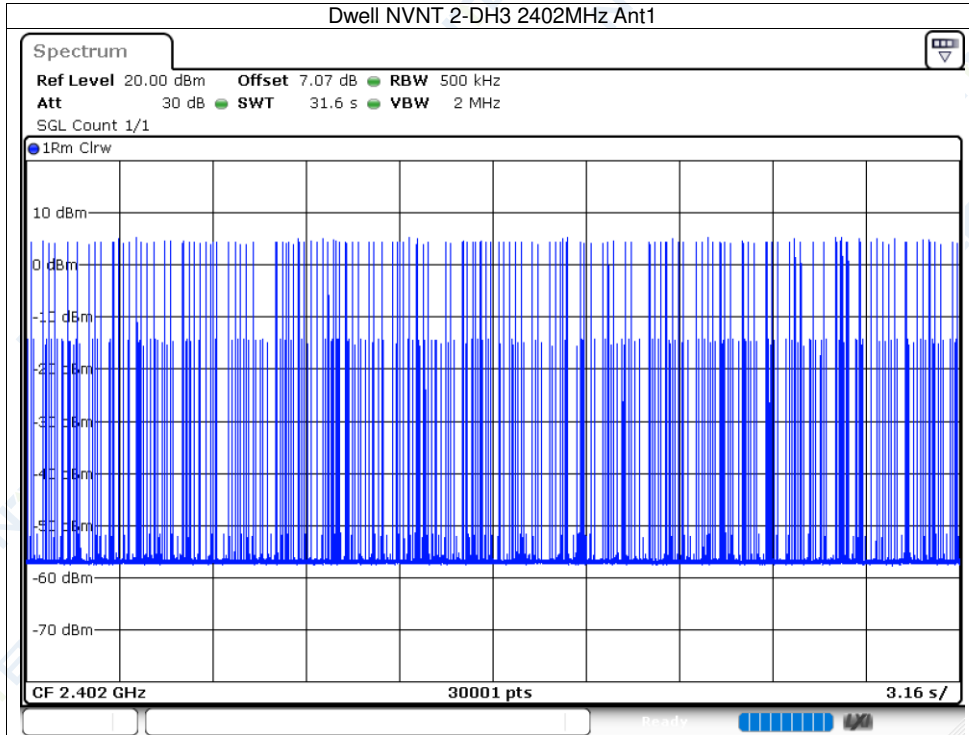

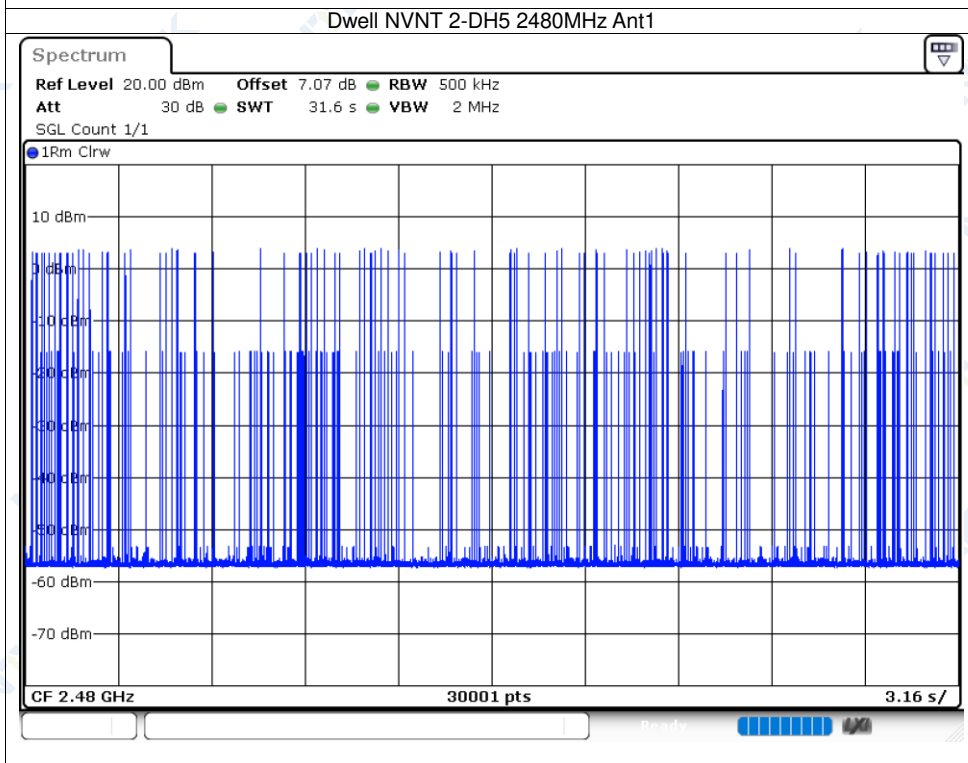
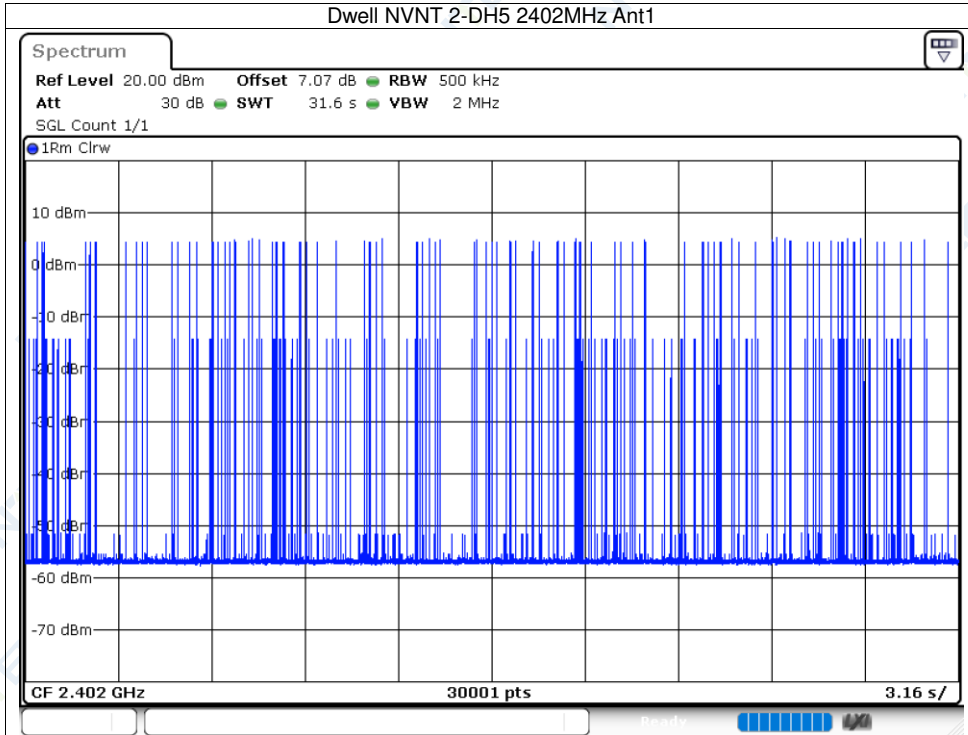



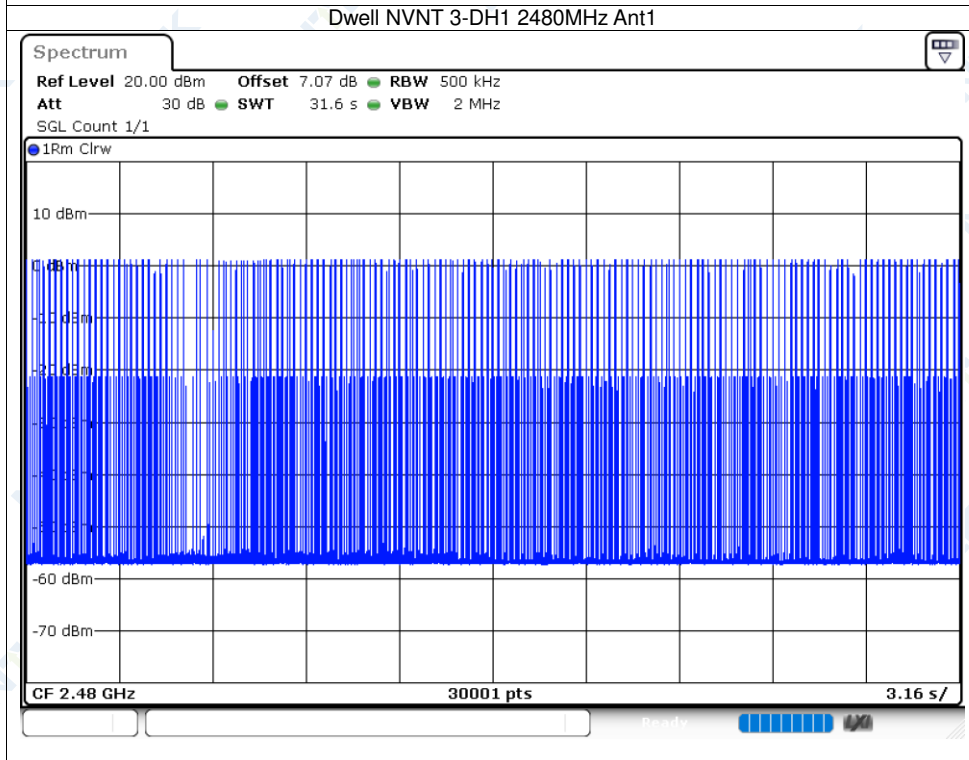
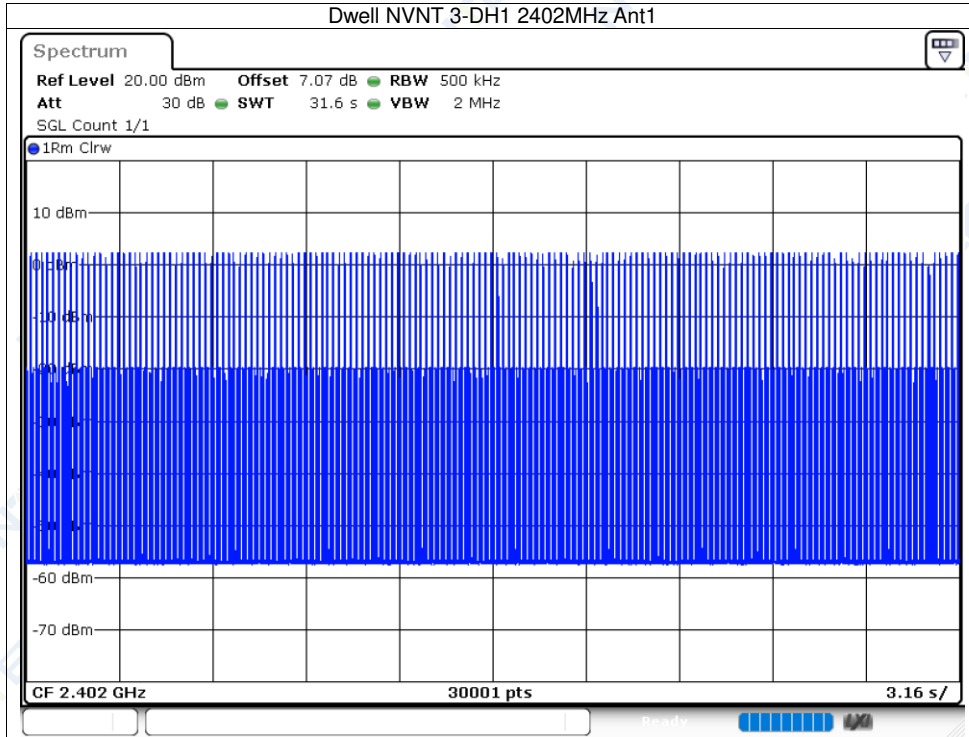

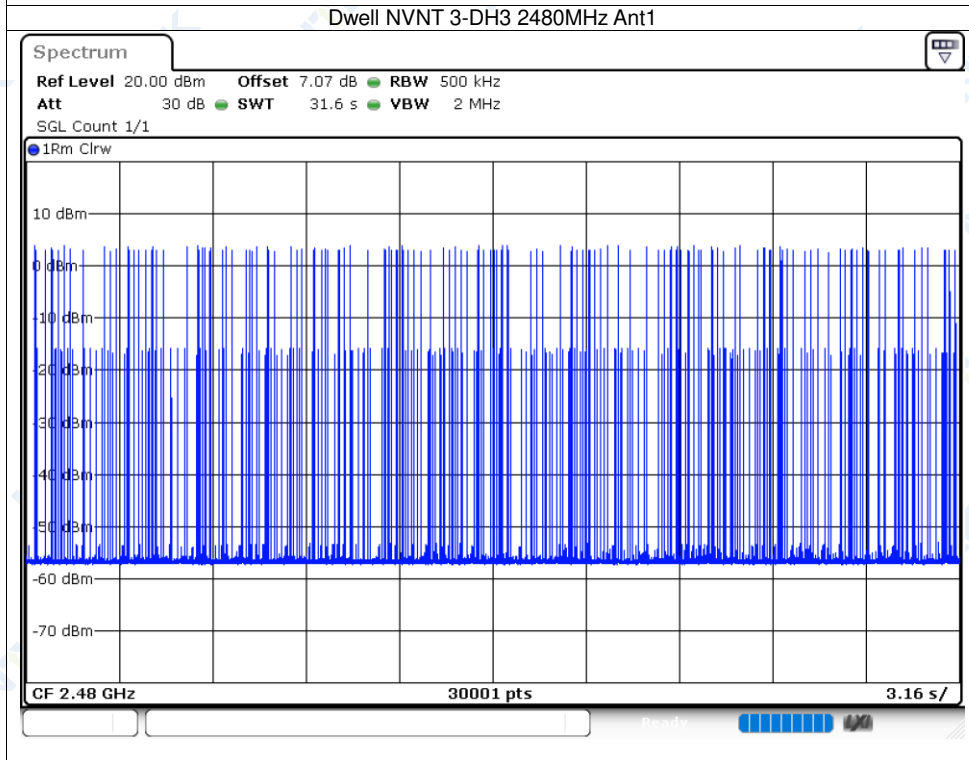
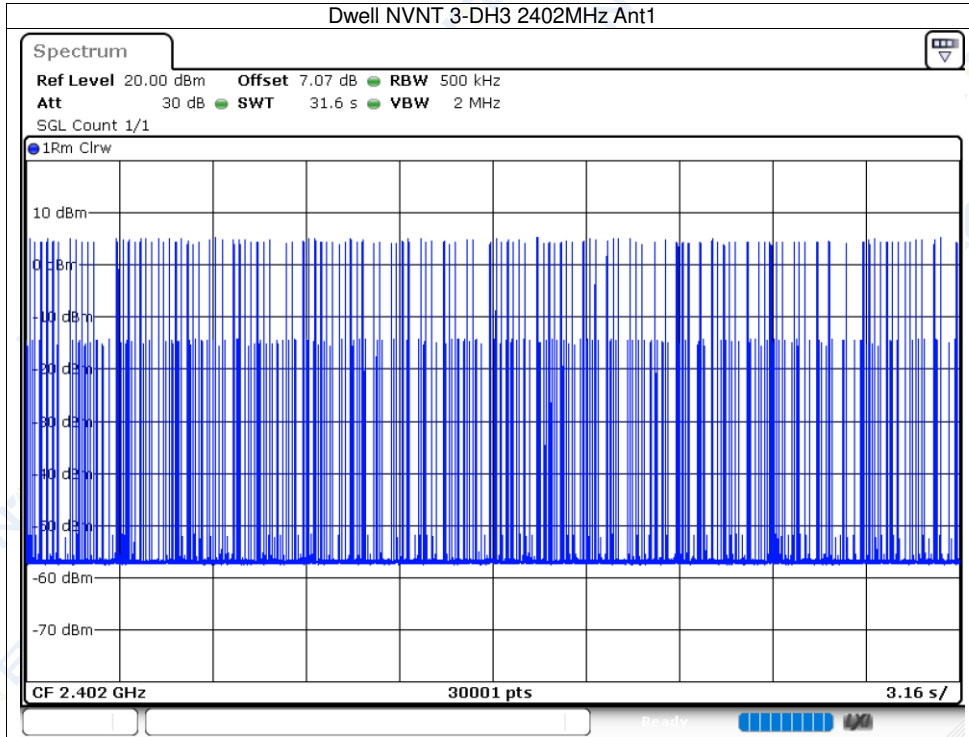

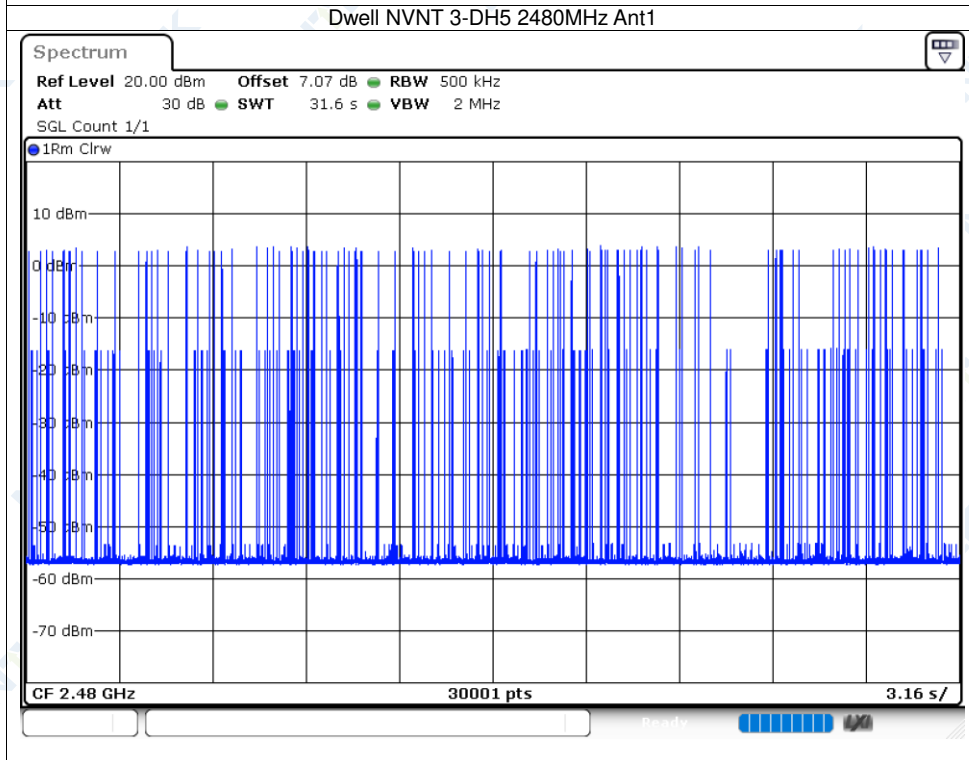
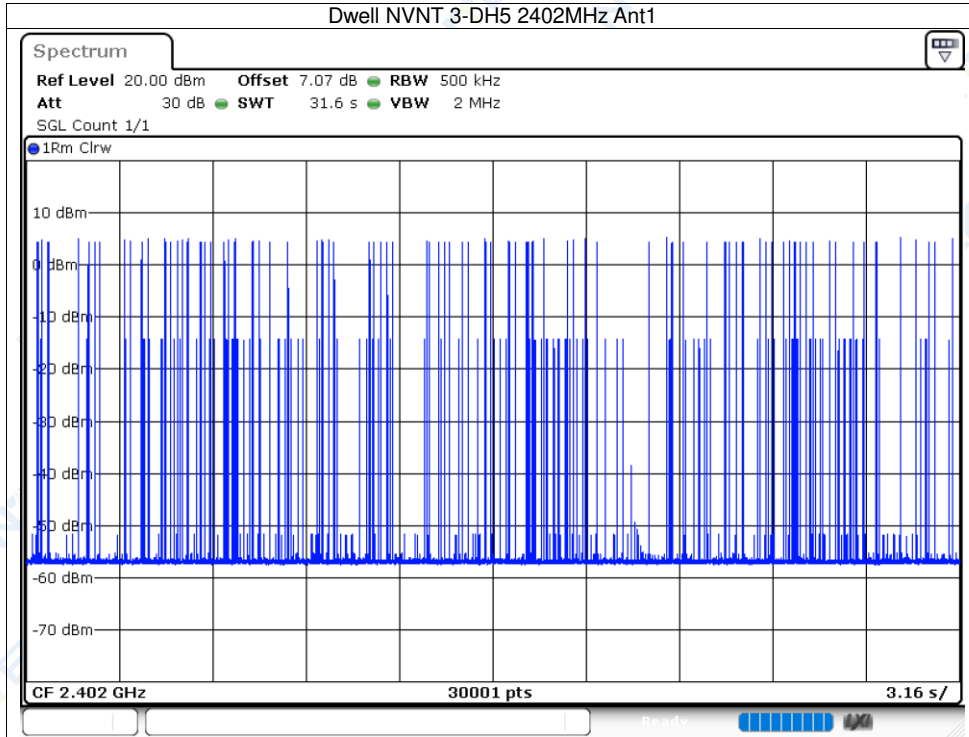

### 11.2 Frequency Occupation

Condition	Mode	Frequency (MHz)	Antenna	Burst Number	Limit	Sweep Time (ms)	Verdict
NVNT	1-DH1	2402	Ant1	1	1	119.448	Pass
NVNT	1-DH1	2480	Ant1	2	1	119.448	Pass
NVNT	1-DH3	2402	Ant1	1	1	516.344	Pass
NVNT	1-DH3	2480	Ant1	6	1	516.344	Pass
NVNT	1-DH5	2402	Ant1	6	1	910.712	Pass
NVNT	1-DH5	2480	Ant1	2	1	910.08	Pass
NVNT	2-DH1	2402	Ant1	1	1	121.66	Pass
NVNT	2-DH1	2480	Ant1	2	1	121.66	Pass
NVNT	2-DH3	2402	Ant1	4	1	516.976	Pass
NVNT	2-DH3	2480	Ant1	3	1	516.976	Pass
NVNT	2-DH5	2402	Ant1	6	1	911.66	Pass
NVNT	2-DH5	2480	Ant1	4	1	911.344	Pass
NVNT	3-DH1	2402	Ant1	3	1	121.976	Pass
NVNT	3-DH1	2480	Ant1	1	1	121.976	Pass
NVNT	3-DH3	2402	Ant1	1	1	516.976	Pass
NVNT	3-DH3	2480	Ant1	5	1	516.976	Pass
NVNT	3-DH5	2402	Ant1	5	1	912.292	Pass
NVNT	3-DH5	2480	Ant1	1	1	911.976	Pass

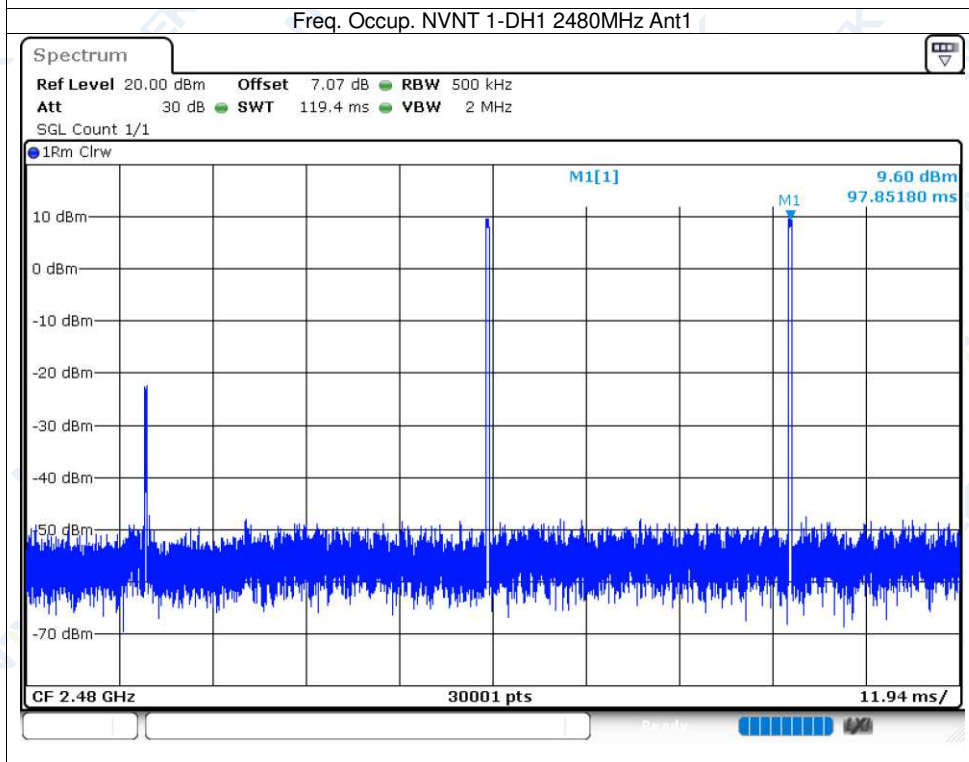
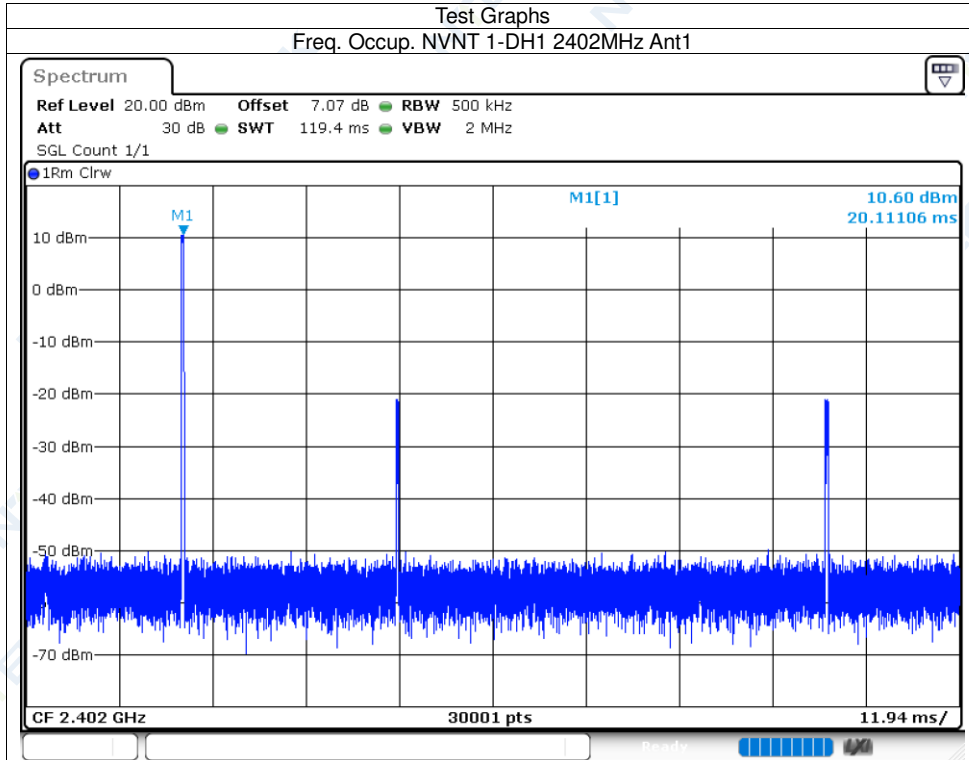

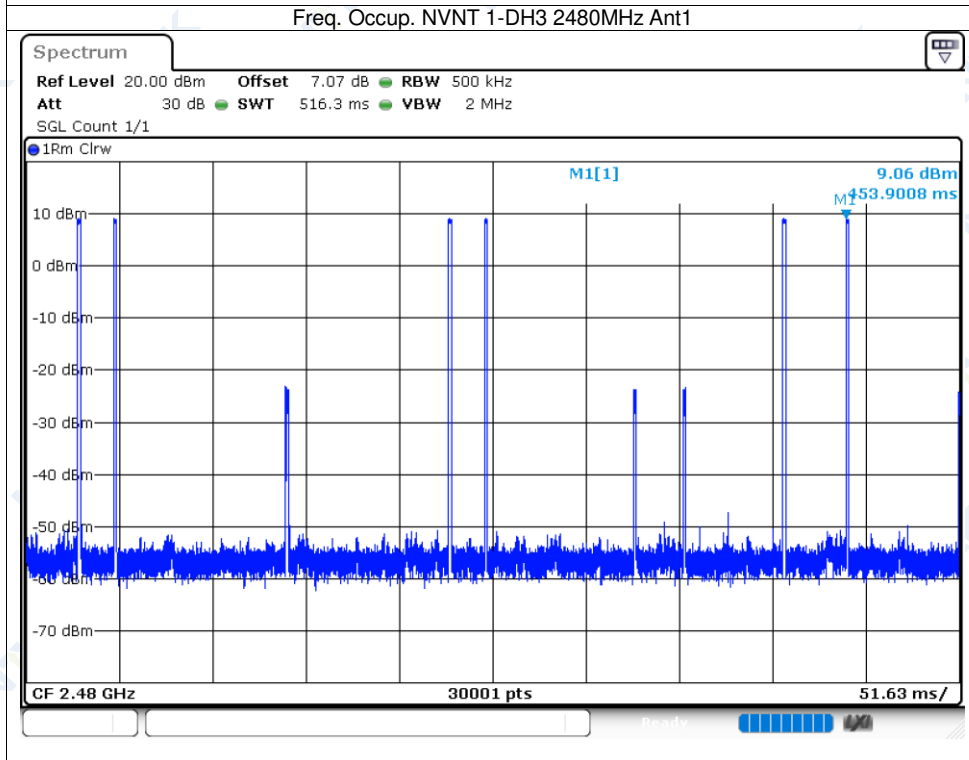
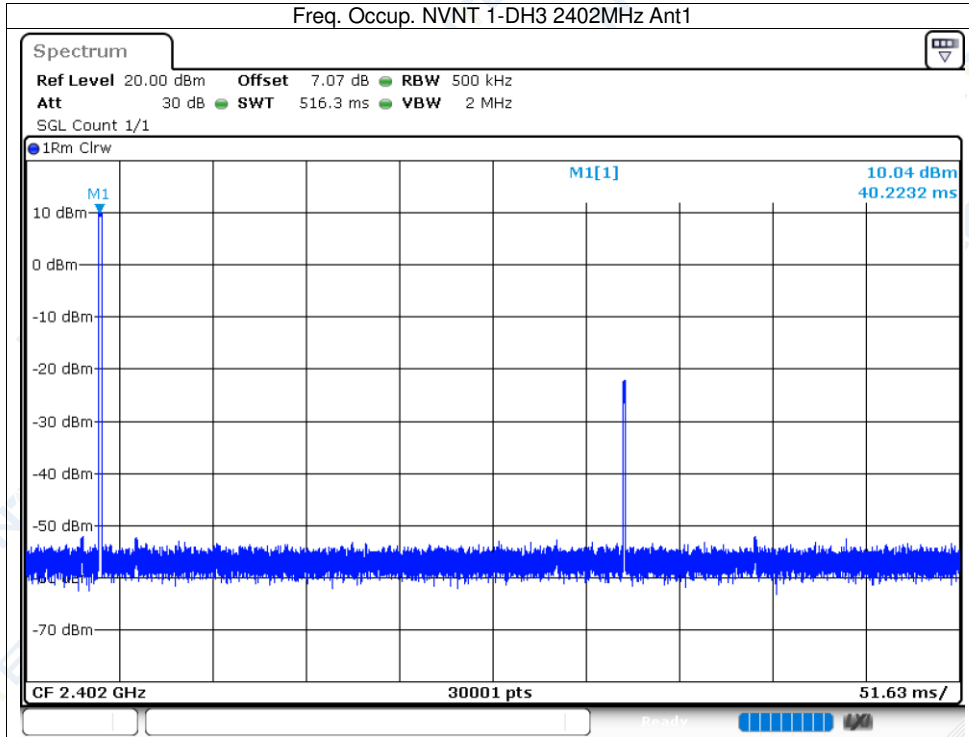

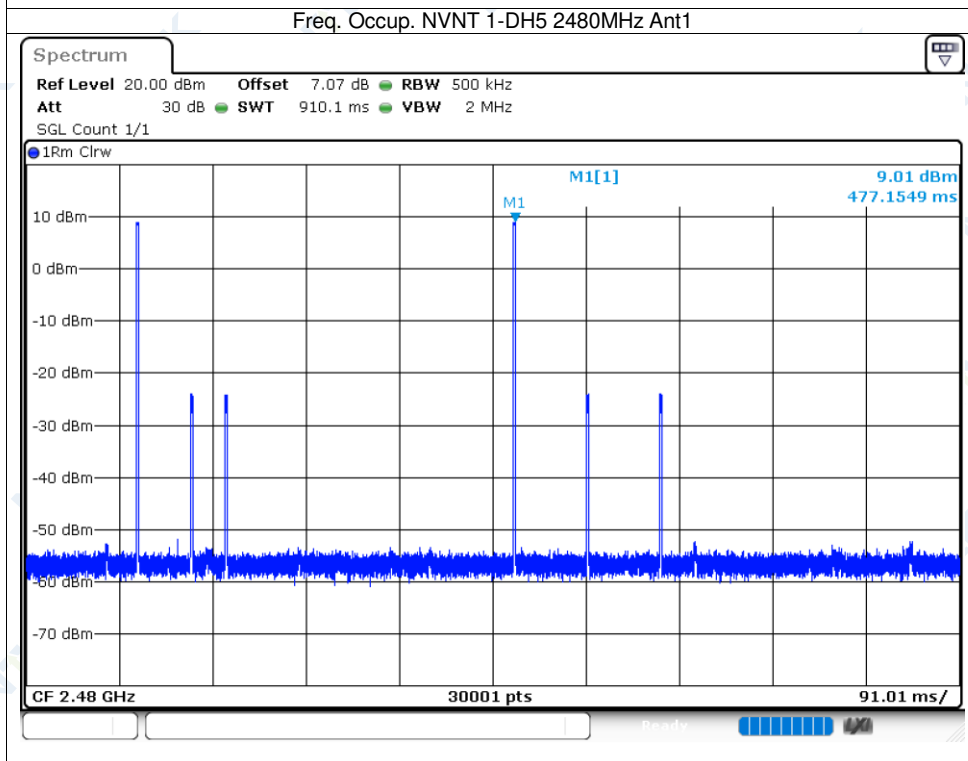
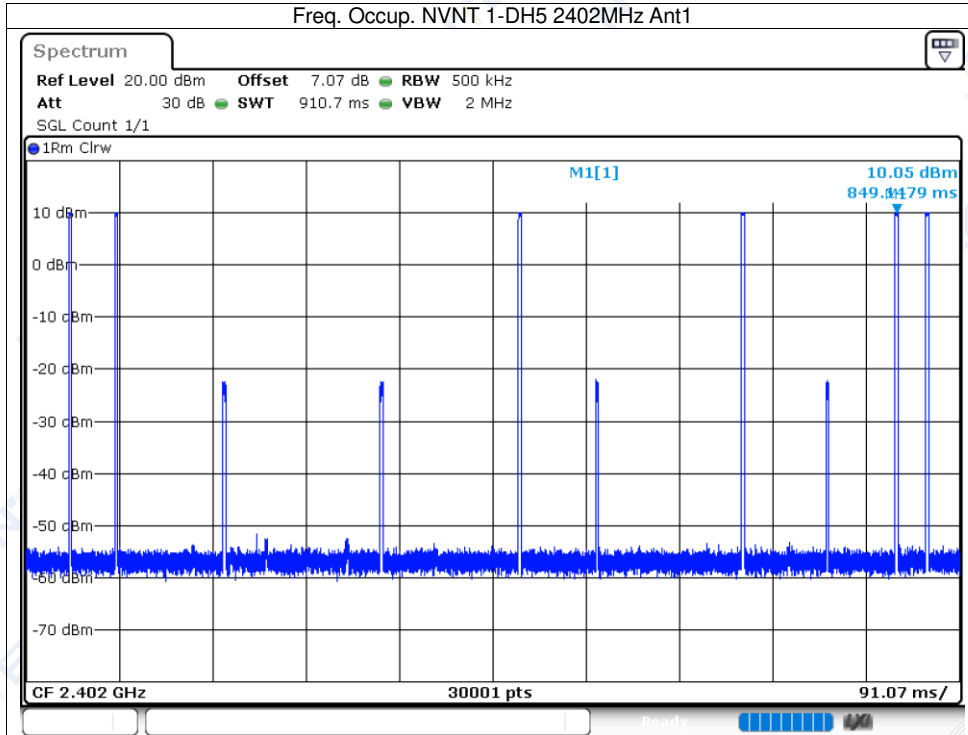



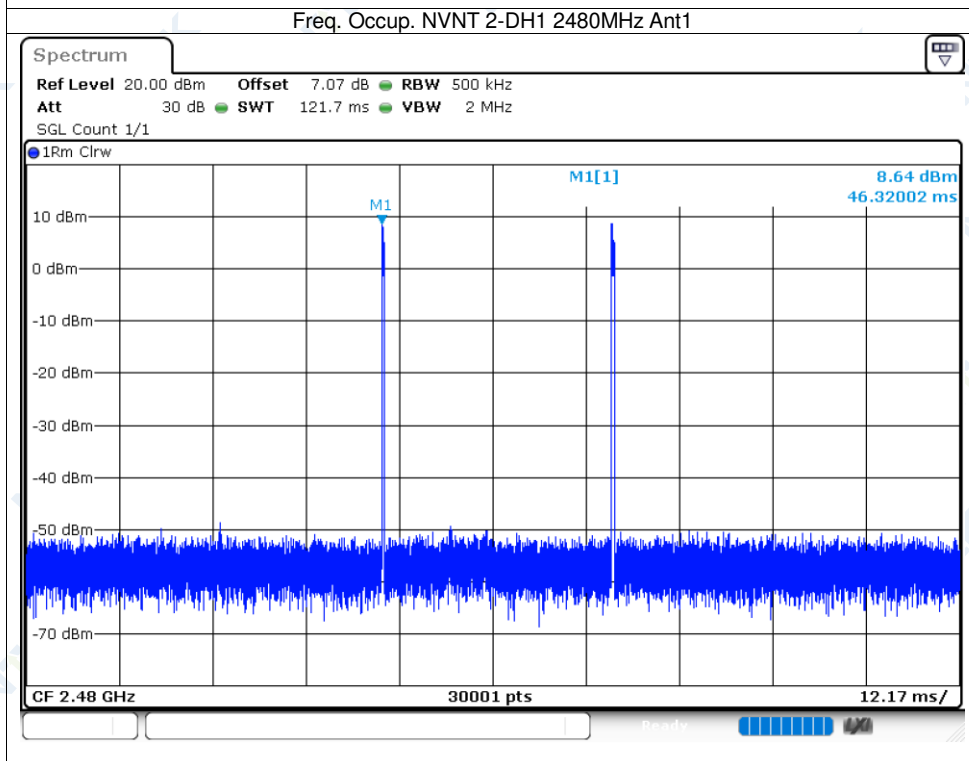
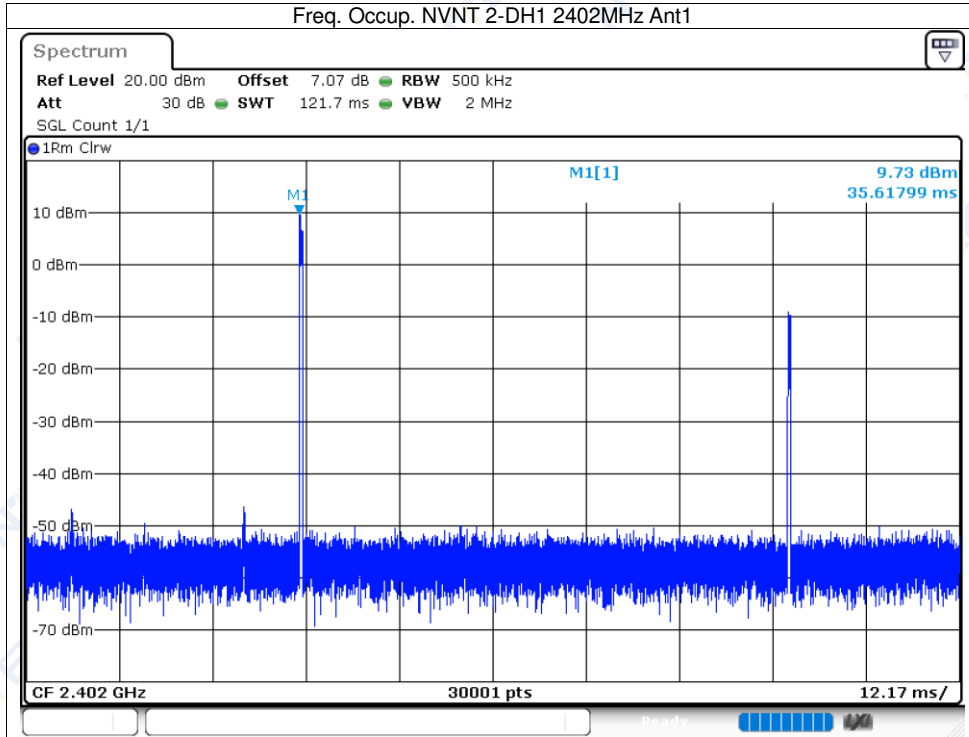

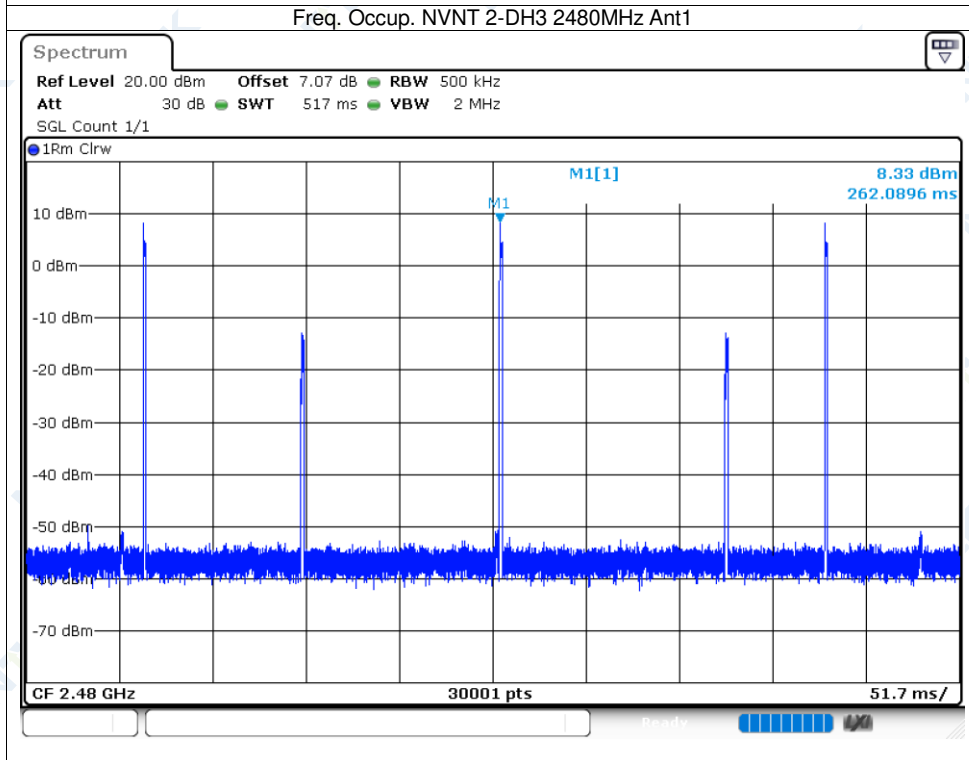
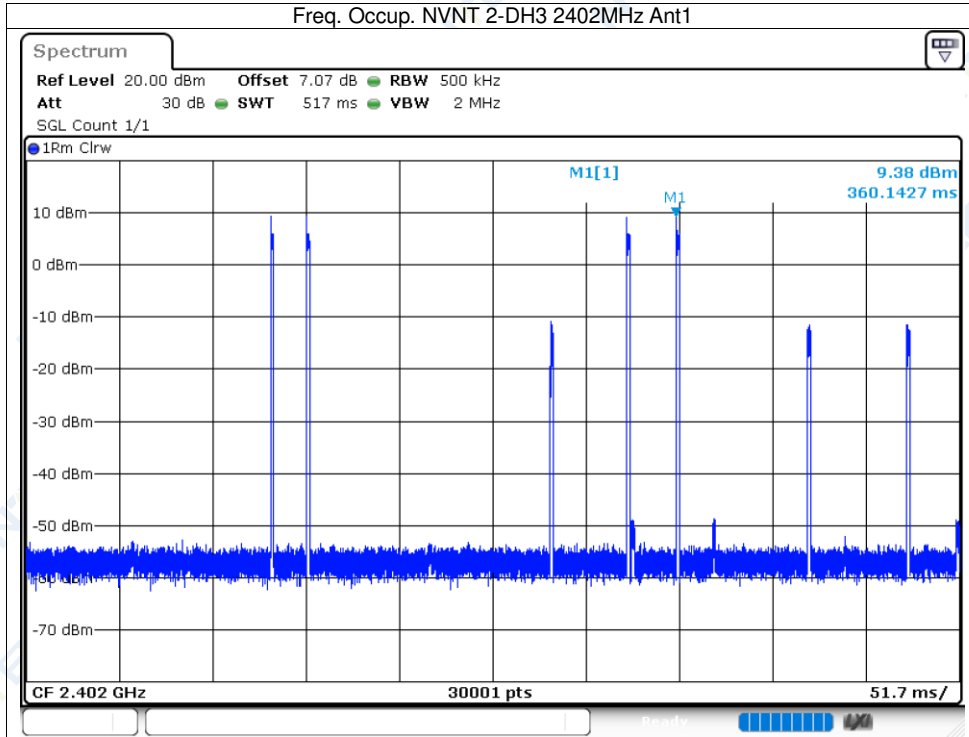

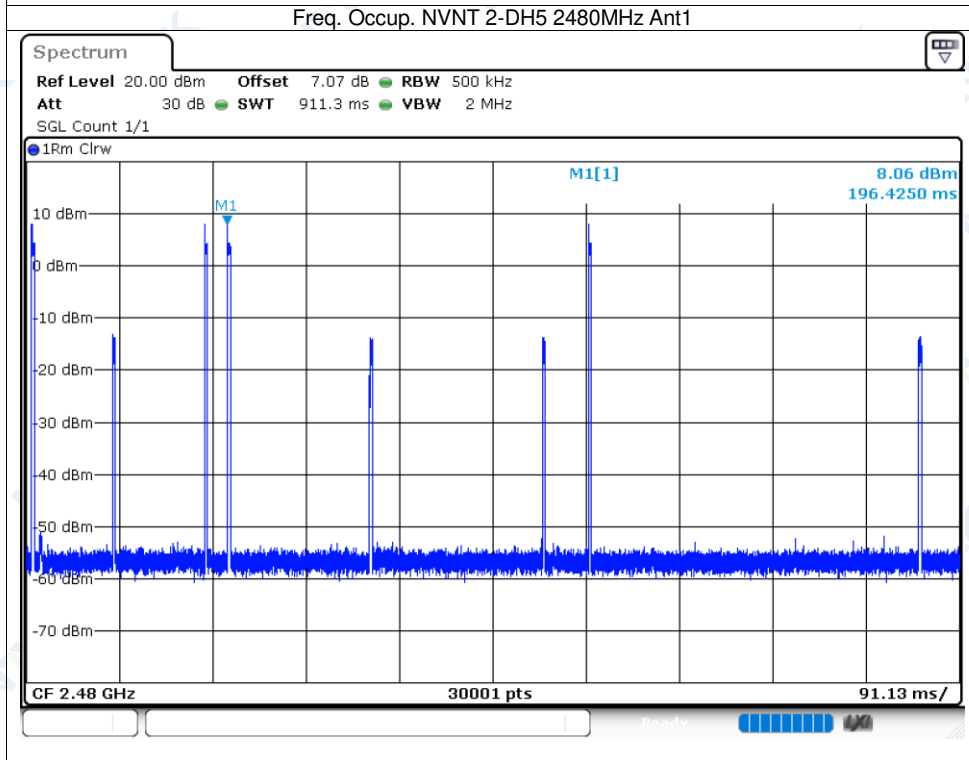
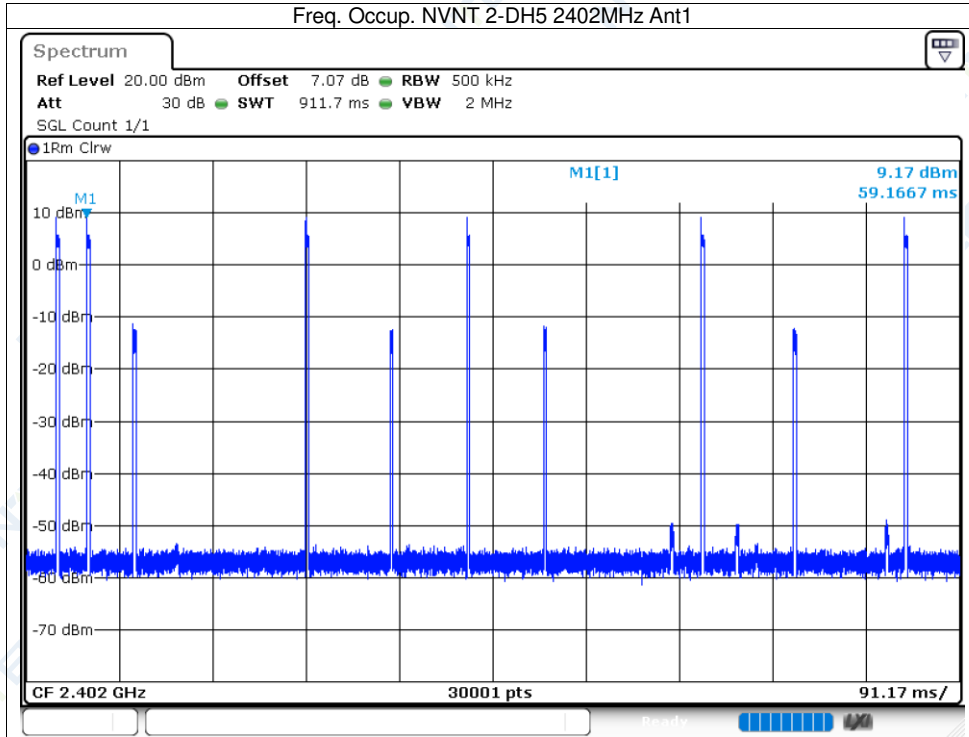

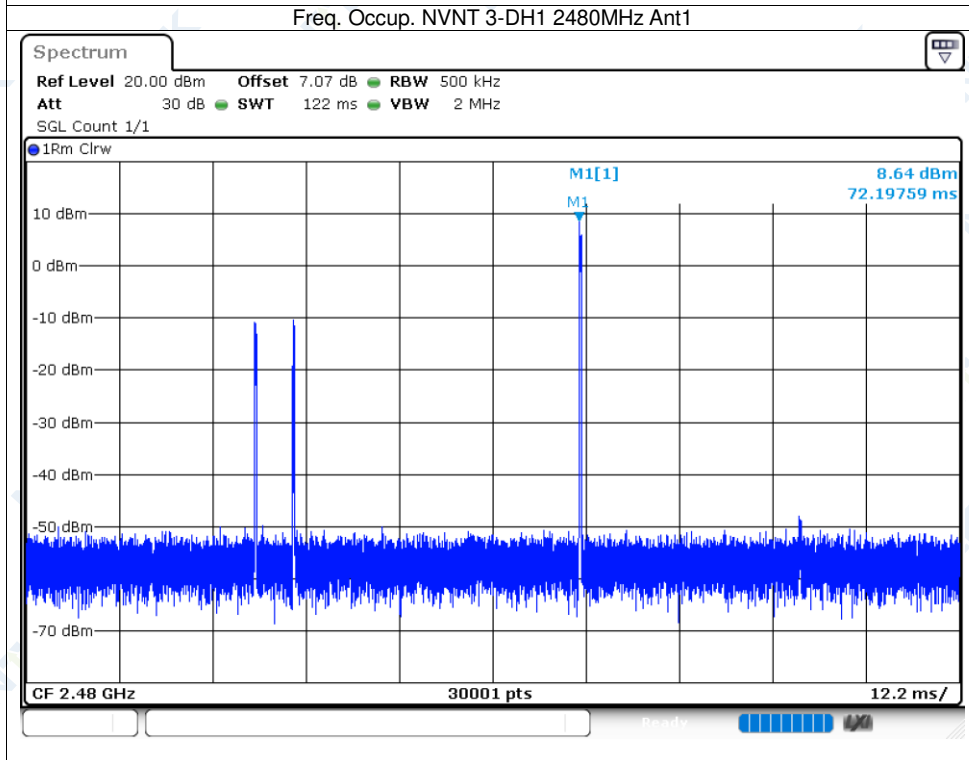
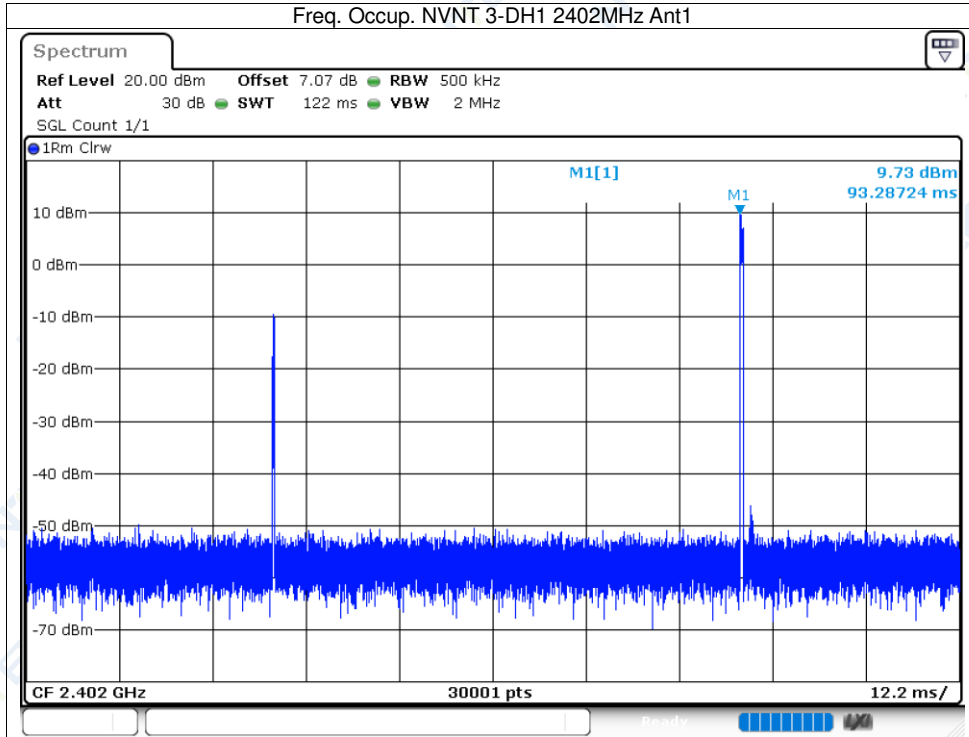

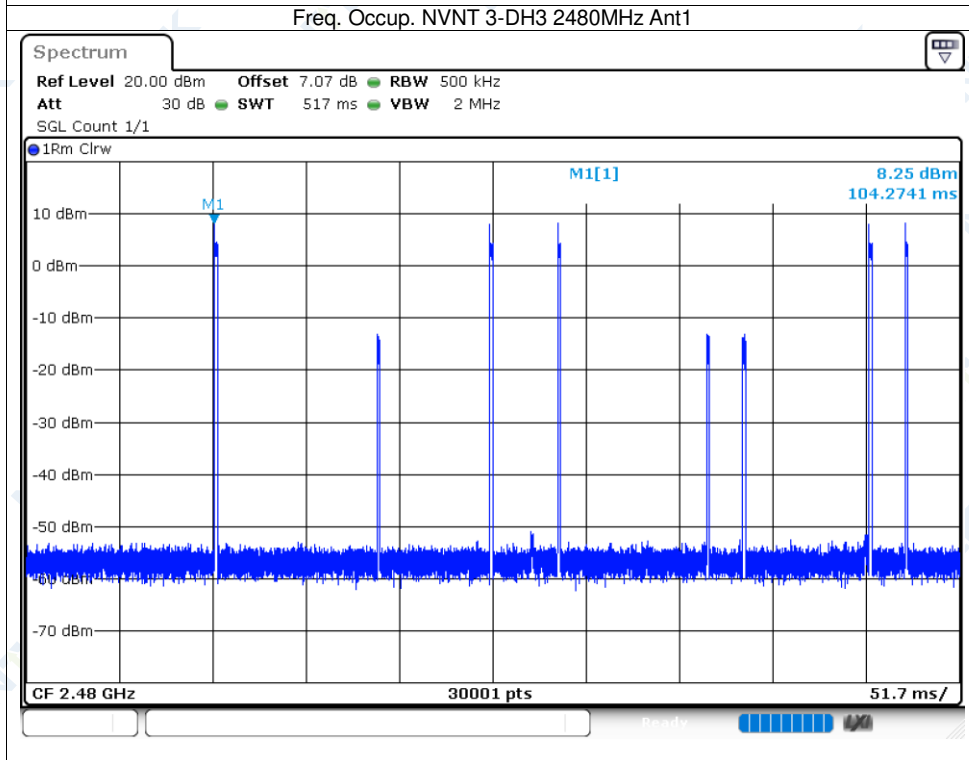
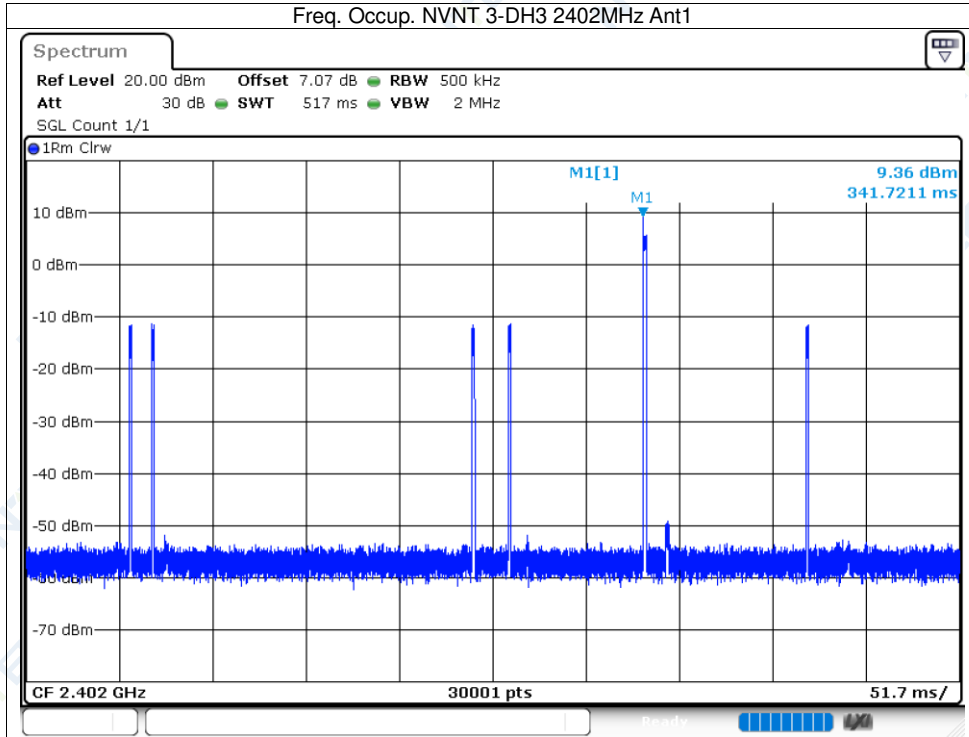

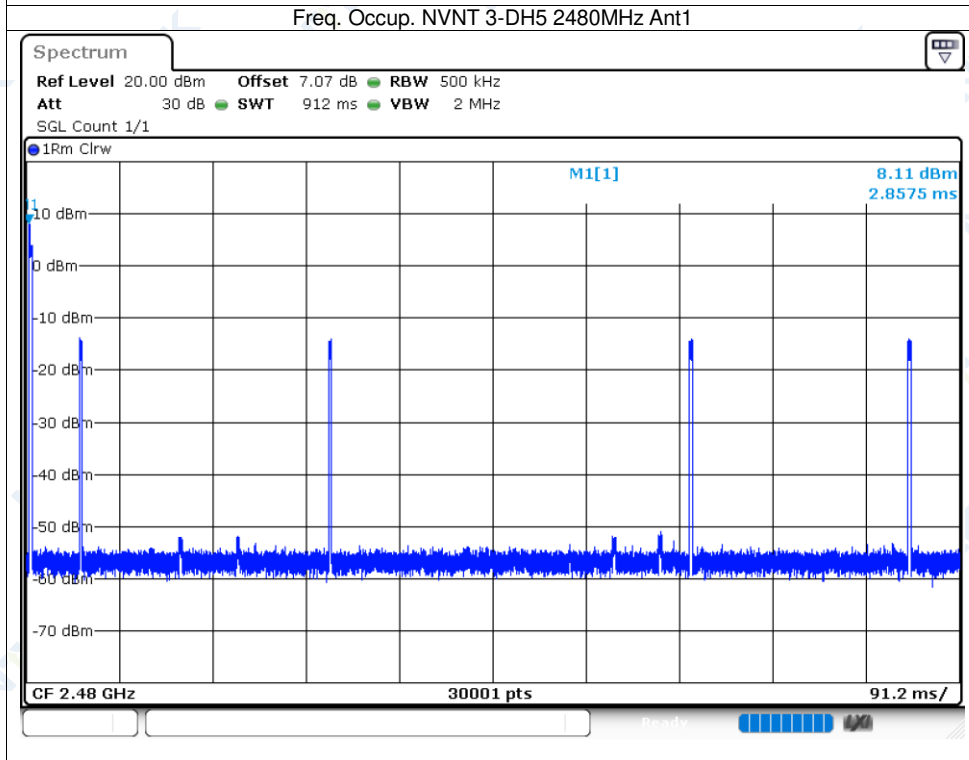
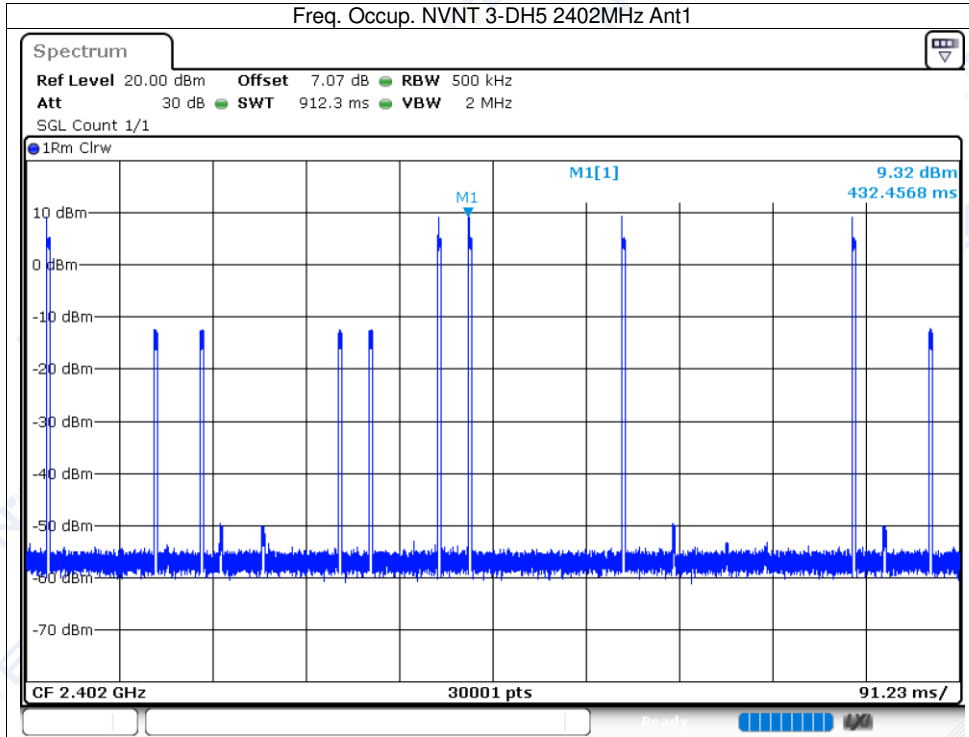

### 11.3 Dwell Time One Burst

Condition	Mode	Frequency (MHz)	Antenna	Pulse Time (ms)
NVNT	1-DH1	2402	Ant1	0.378
NVNT	1-DH1	2480	Ant1	0.378
NVNT	1-DH3	2402	Ant1	1.634
NVNT	1-DH3	2480	Ant1	1.634
NVNT	1-DH5	2402	Ant1	2.882
NVNT	1-DH5	2480	Ant1	2.88
NVNT	2-DH1	2402	Ant1	0.385
NVNT	2-DH1	2480	Ant1	0.385
NVNT	2-DH3	2402	Ant1	1.636
NVNT	2-DH3	2480	Ant1	1.636
NVNT	2-DH5	2402	Ant1	2.885
NVNT	2-DH5	2480	Ant1	2.884
NVNT	3-DH1	2402	Ant1	0.386
NVNT	3-DH1	2480	Ant1	0.386
NVNT	3-DH3	2402	Ant1	1.636
NVNT	3-DH3	2480	Ant1	1.636
NVNT	3-DH5	2402	Ant1	2.887
NVNT	3-DH5	2480	Ant1	2.886



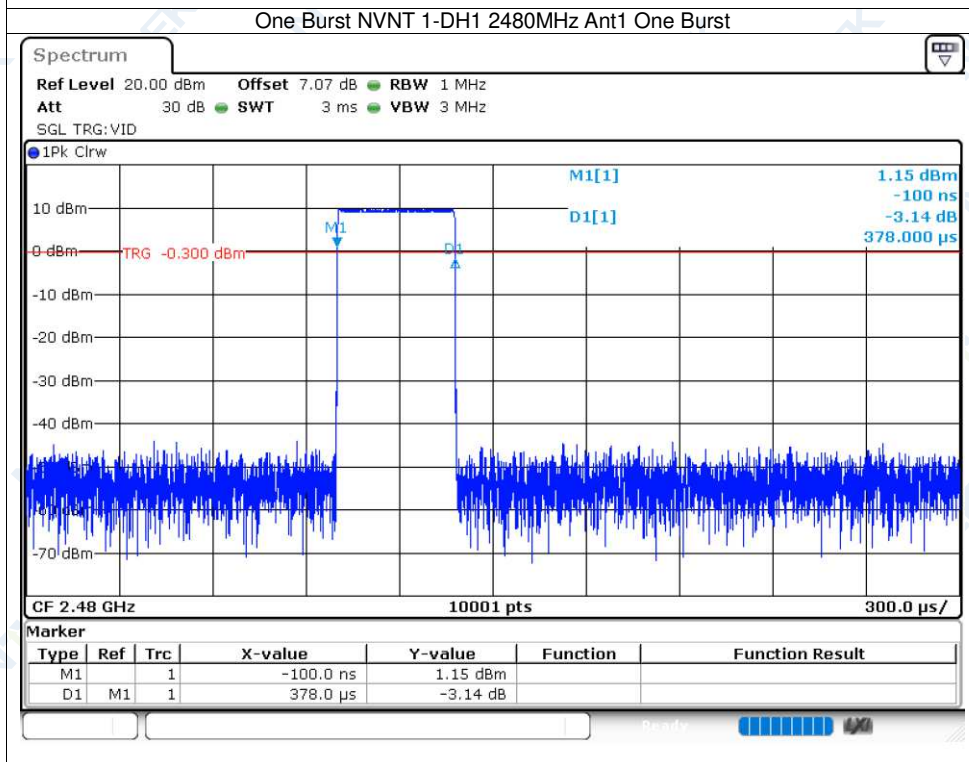
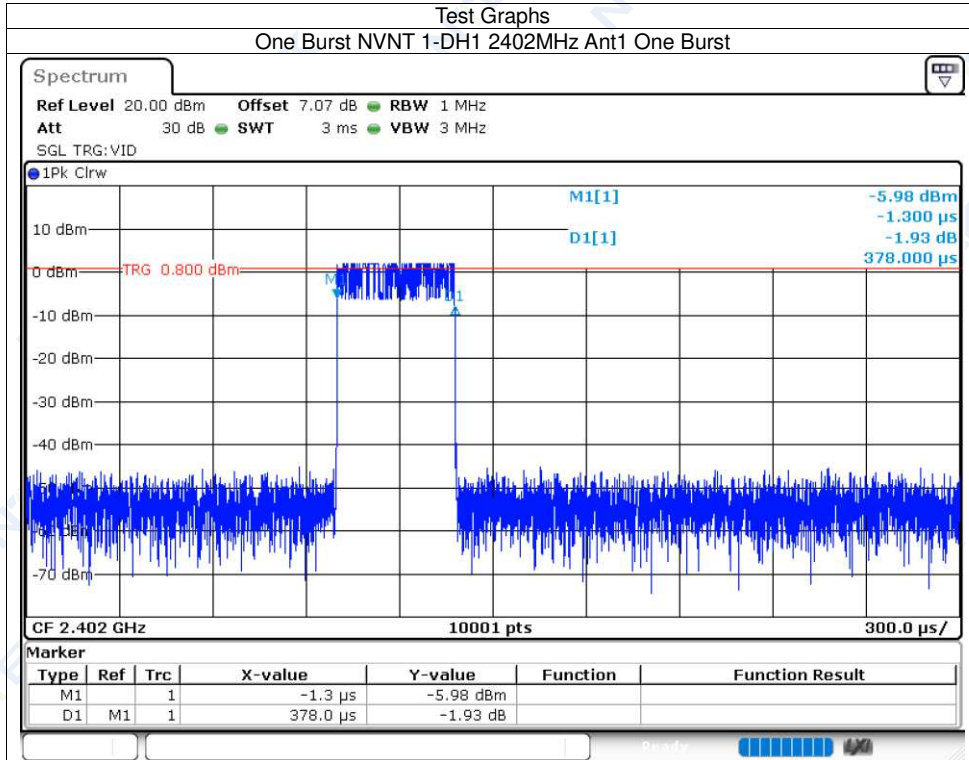

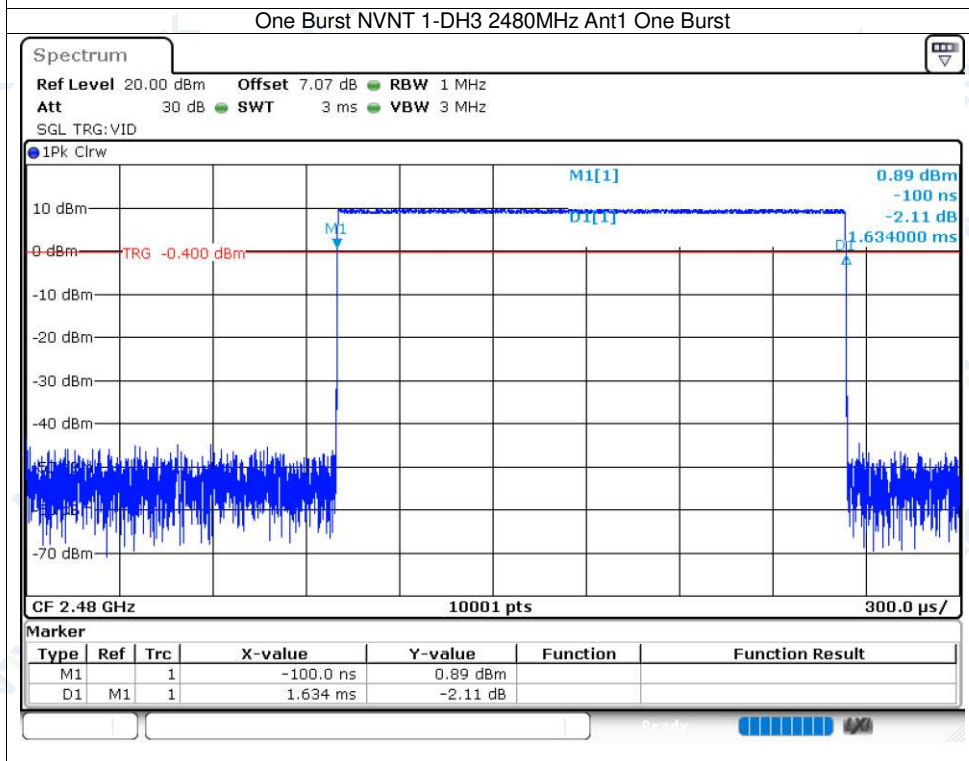
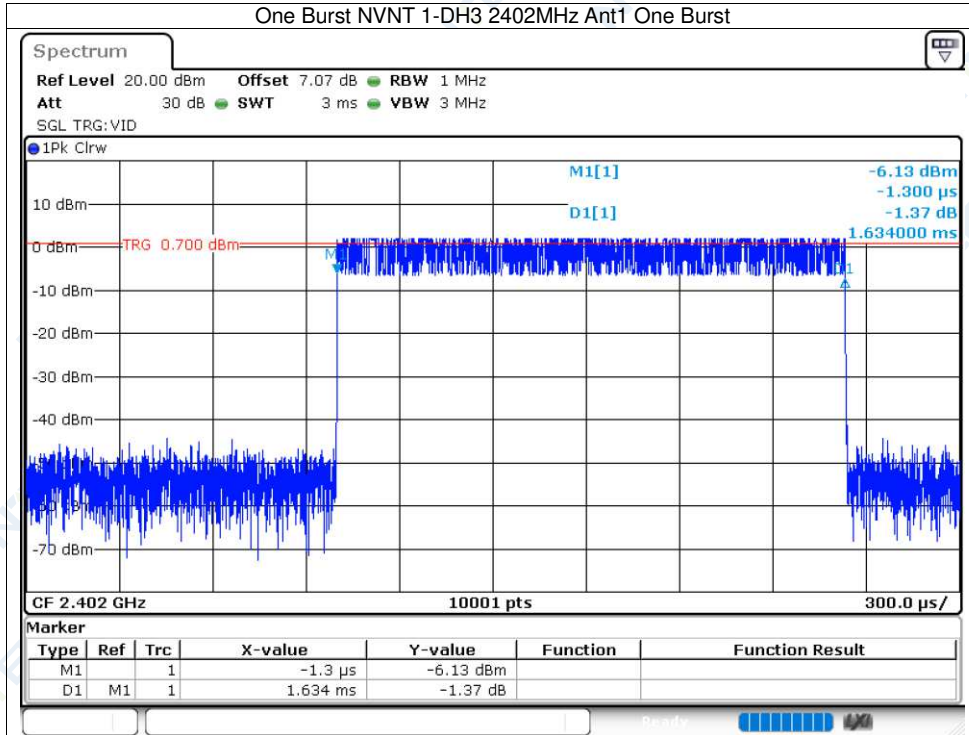

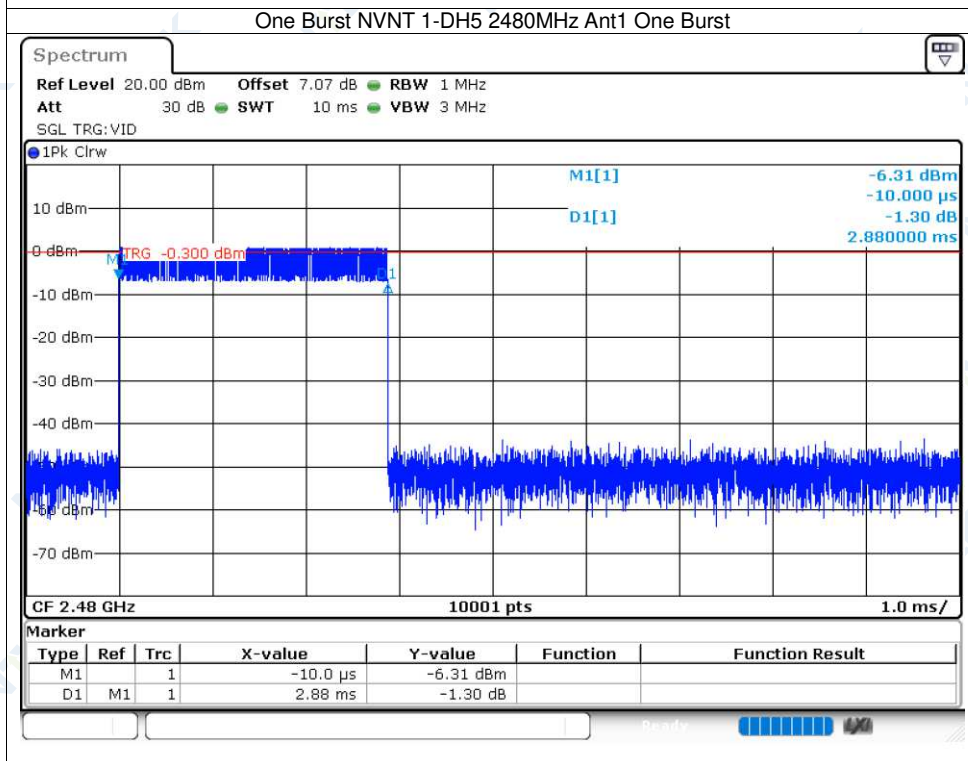
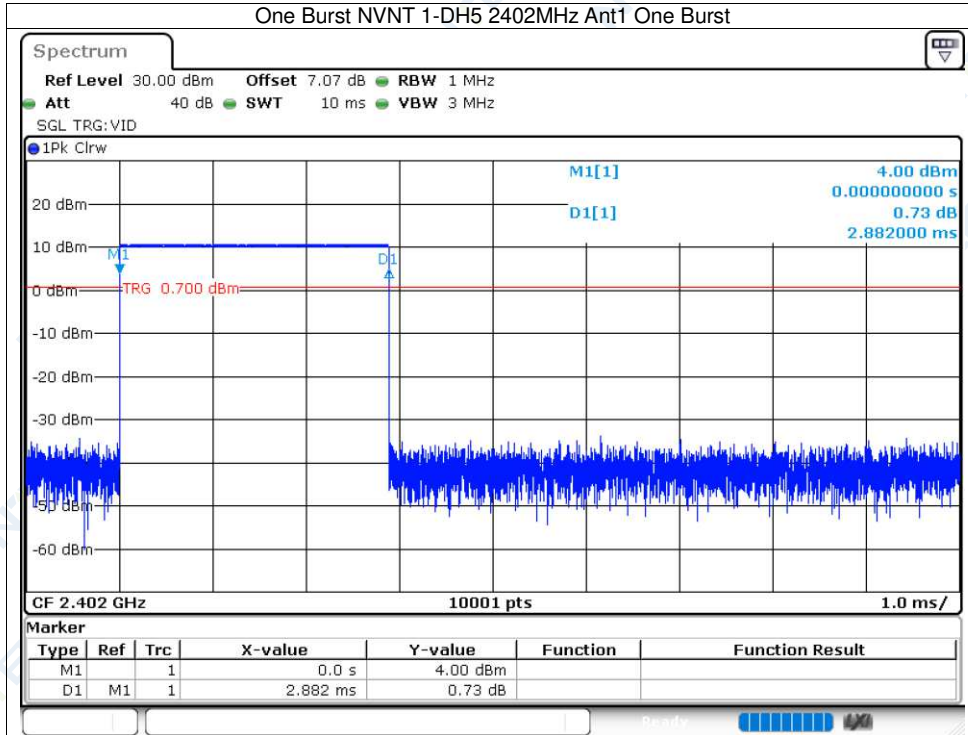

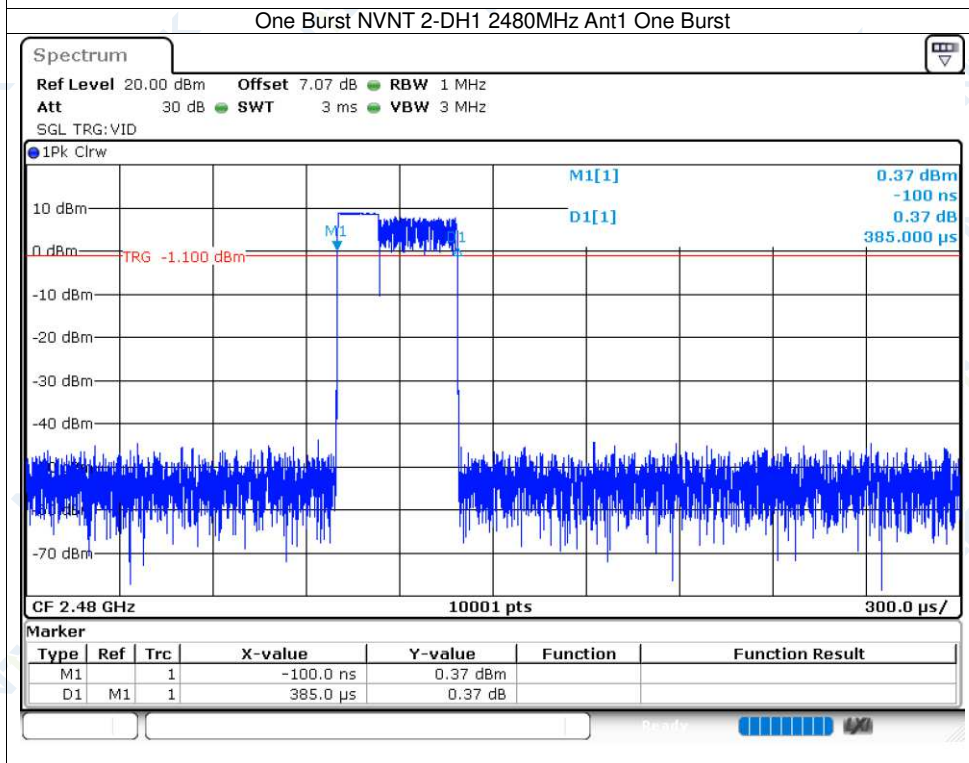
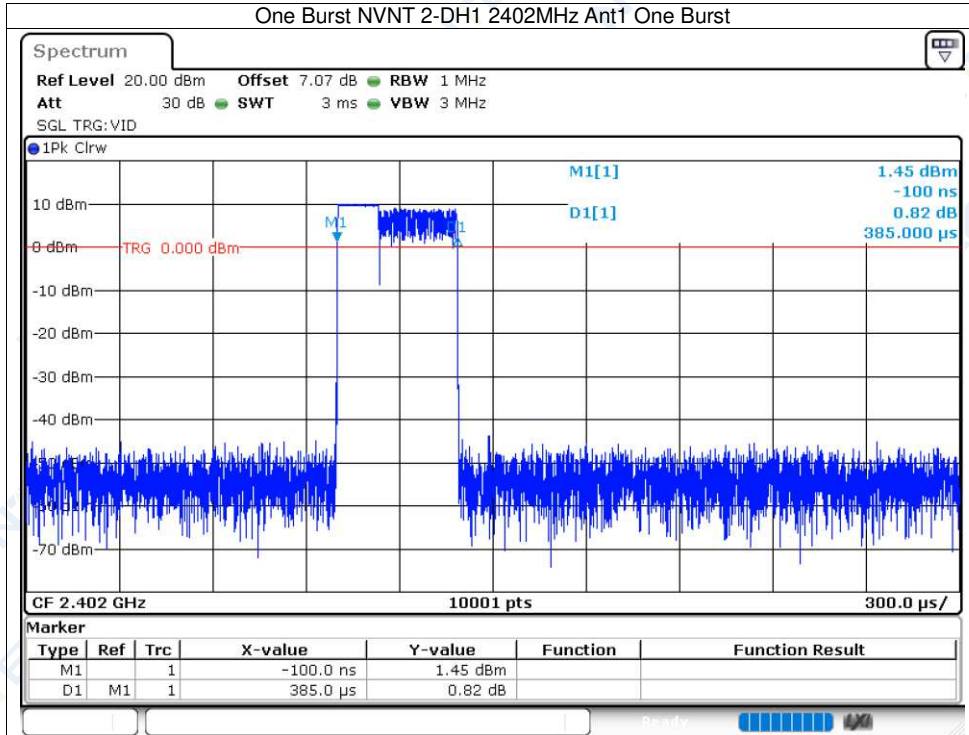



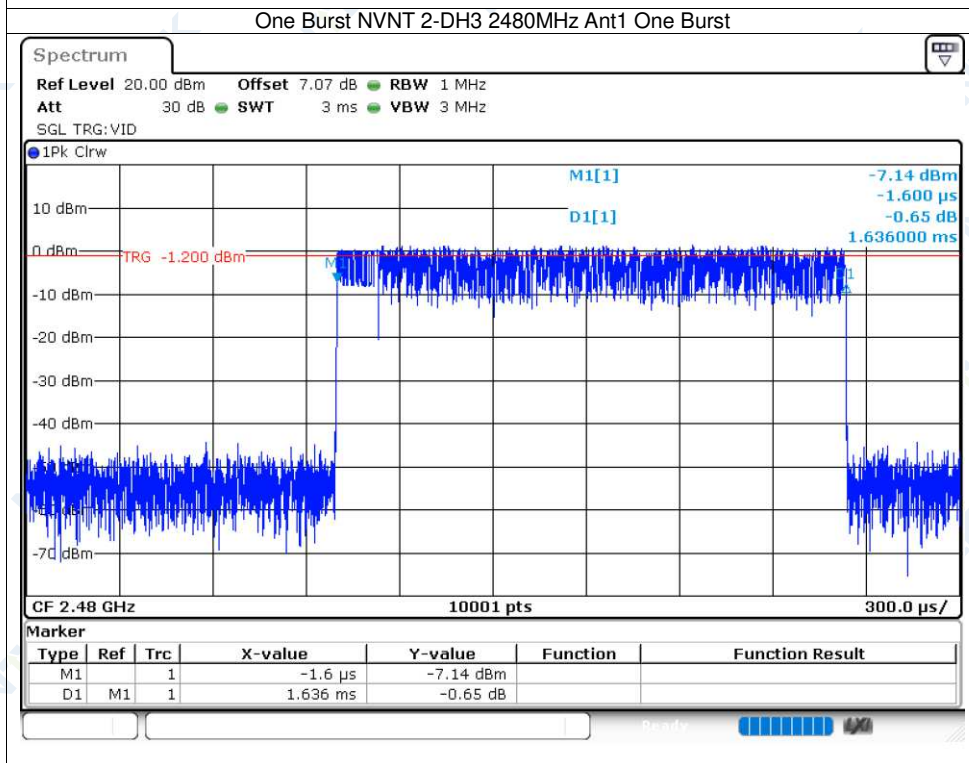
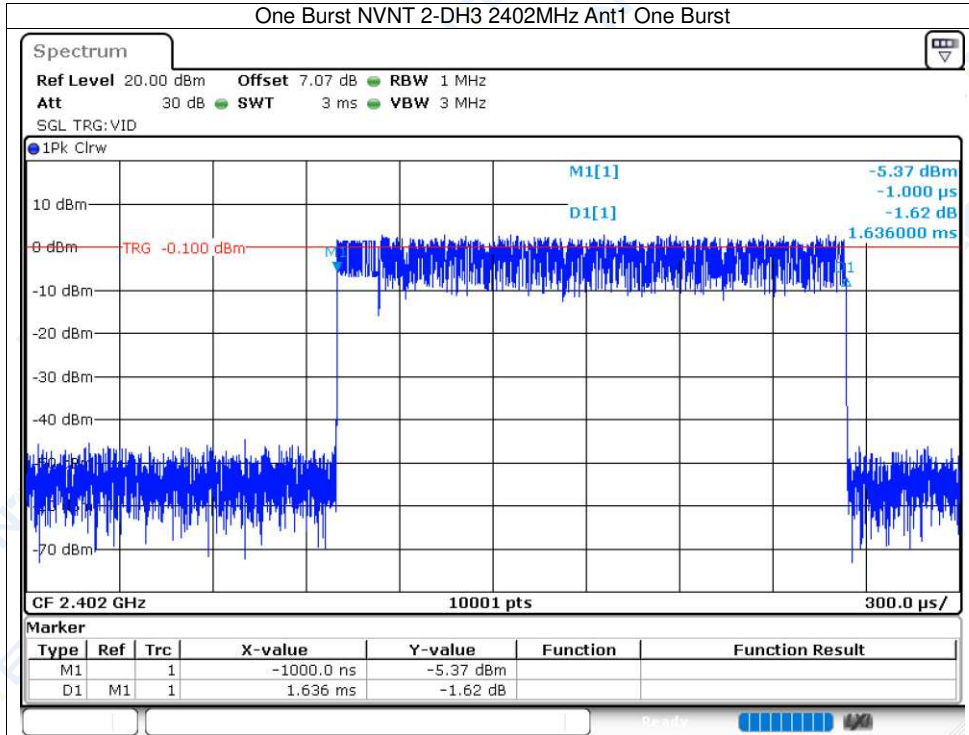

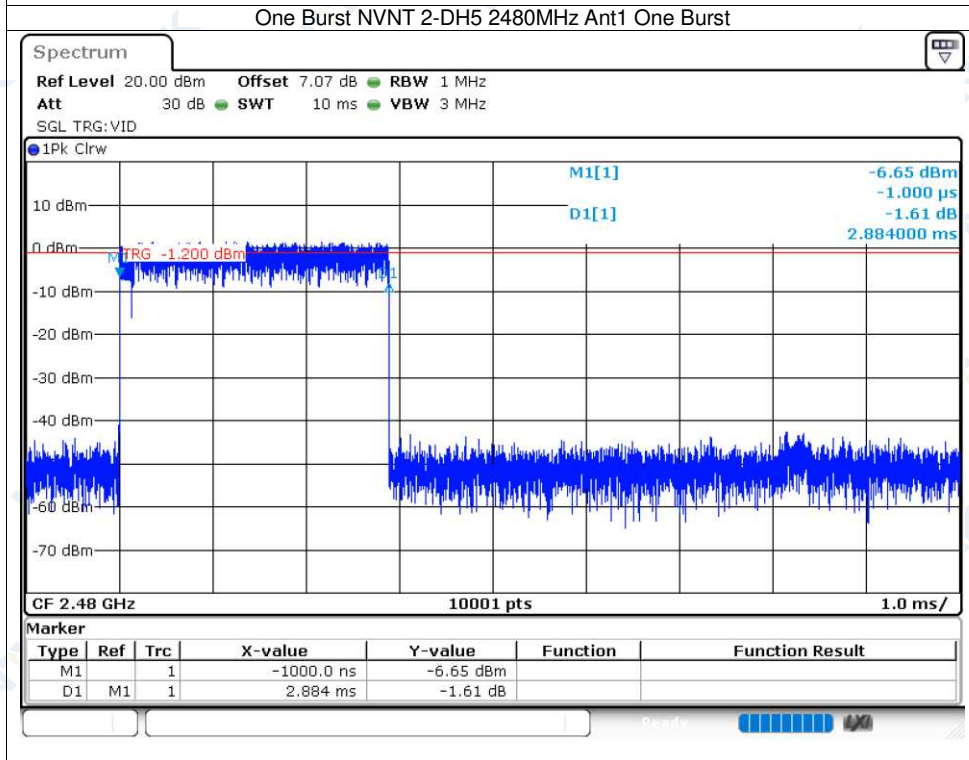
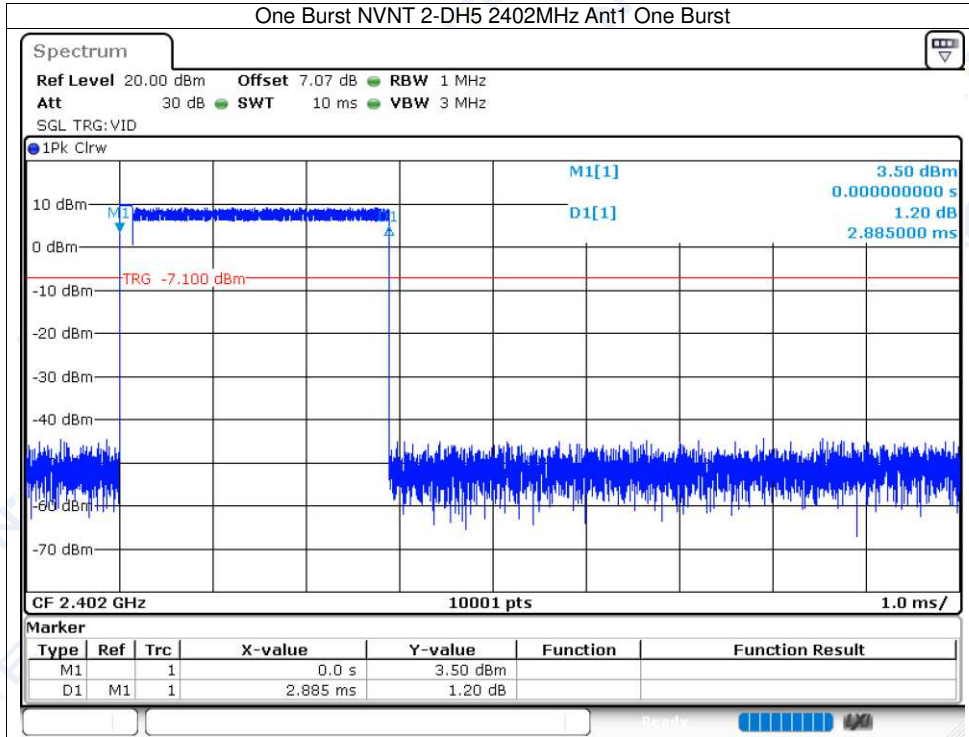

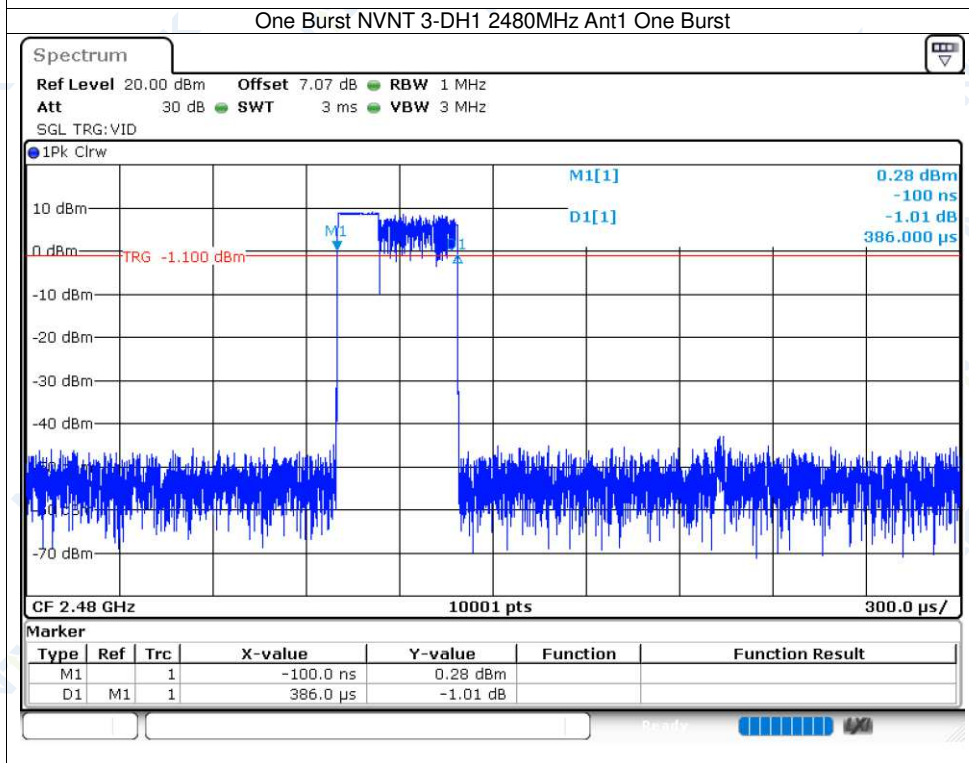
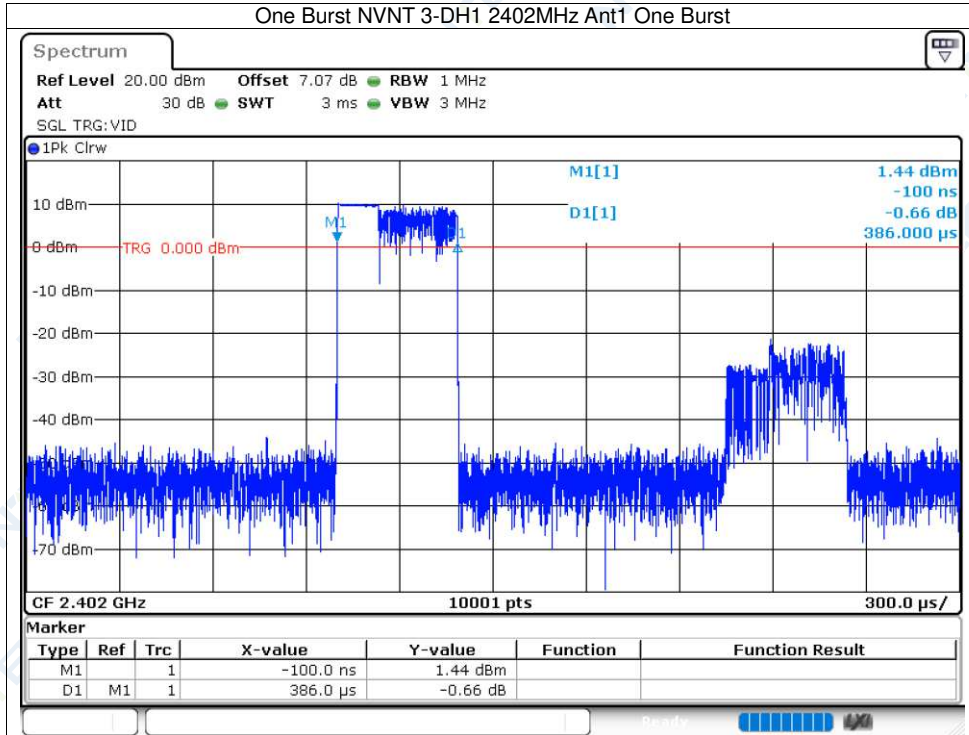



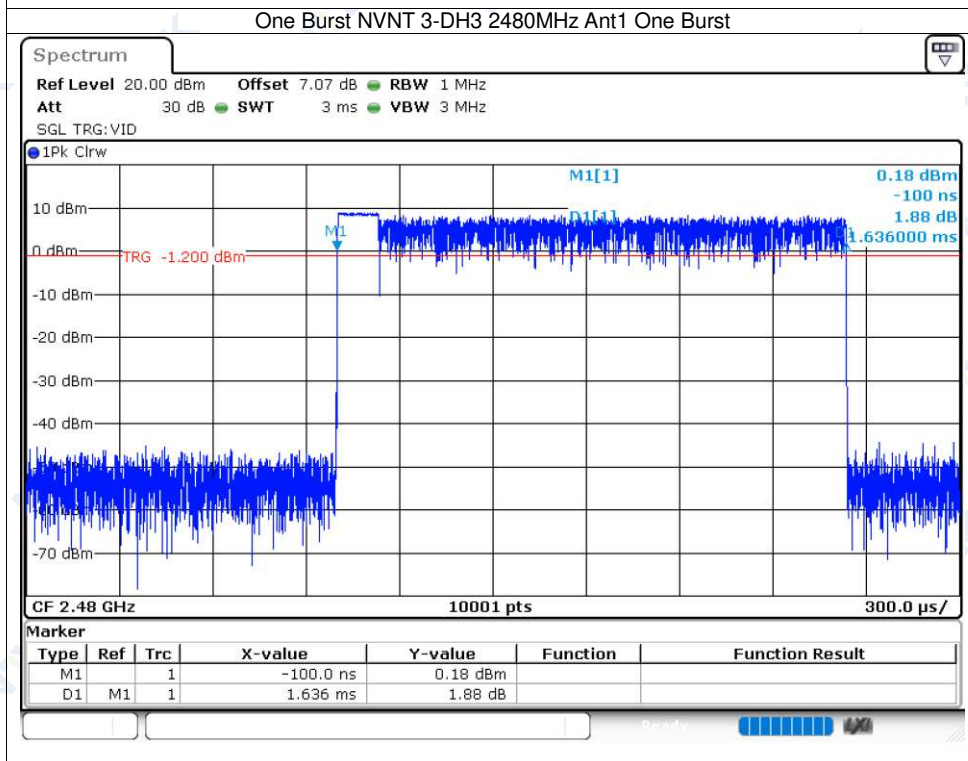
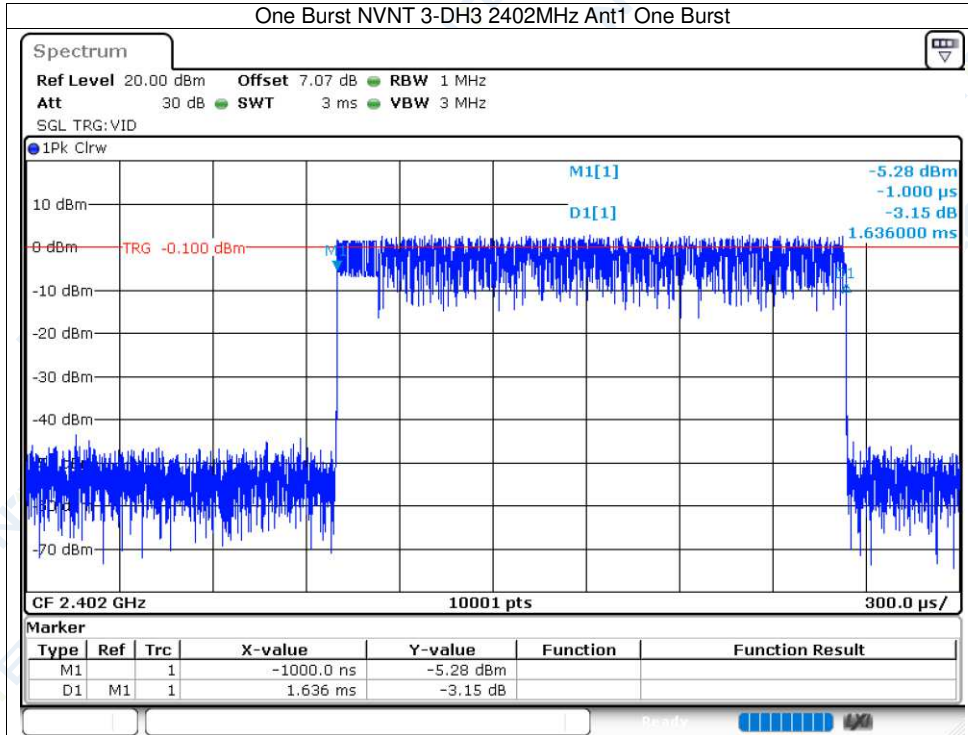

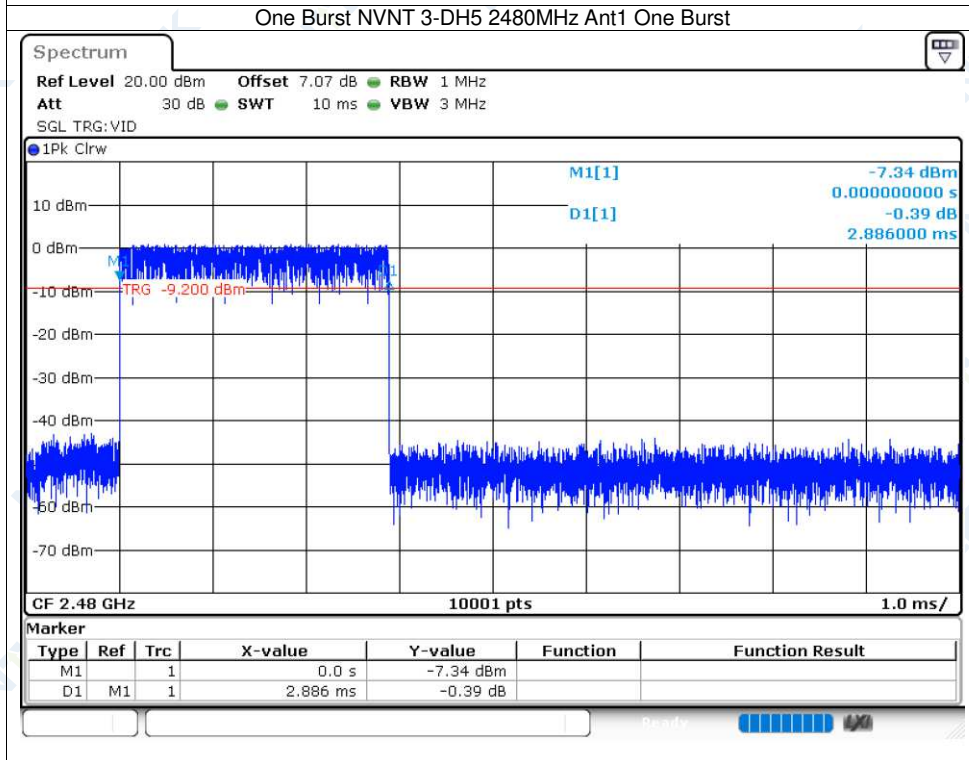
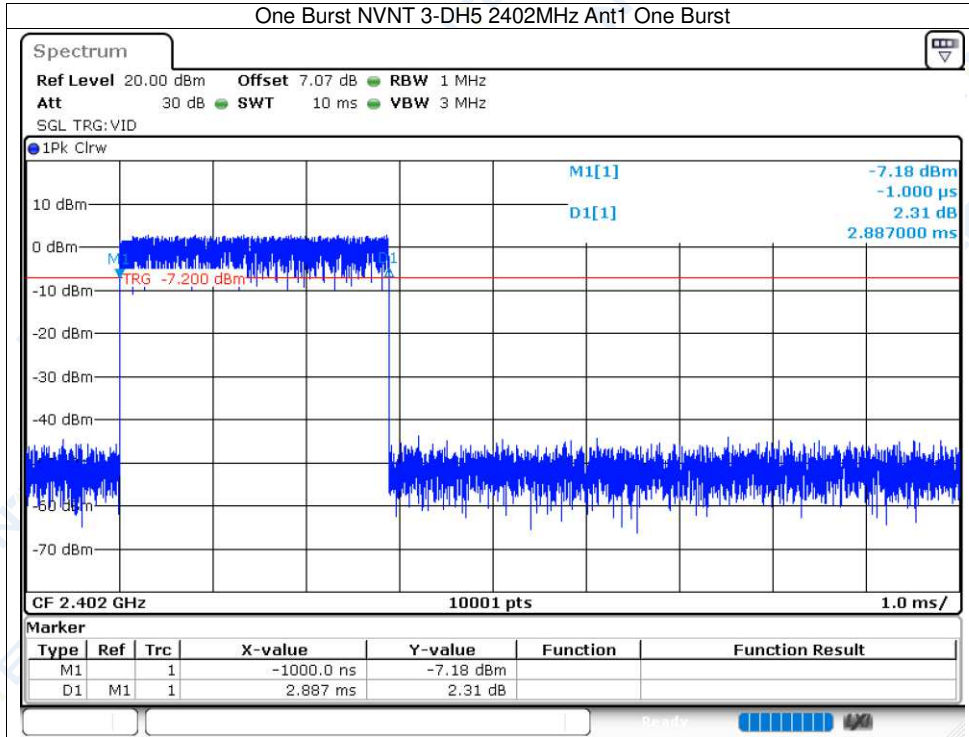

**11.4 RF Output Power**

Condition	Mode	Frequency (MHz)	Antenna	Max Burst RMS Power (dBm)	Burst Number	Max EIRP (dBm)	Limit (dBm)	Verdict
NVNT	1-DH5	hopping	Ant1	8.81	27	9.81	20	Pass
NVNT	2-DH5	hopping	Ant1	5.87	28	6.87	20	Pass
NVNT	3-DH5	hopping	Ant1	5.92	27	6.92	20	Pass
NVLT	1-DH5	hopping	Ant1	8.13	27	9.13	20	Pass
NVLT	2-DH5	hopping	Ant1	5.28	28	6.28	20	Pass
NVLT	3-DH5	hopping	Ant1	5.35	27	6.35	20	Pass
NVHT	1-DH5	hopping	Ant1	8.1	27	9.1	20	Pass
NVHT	2-DH5	hopping	Ant1	5.18	28	6.18	20	Pass
NVHT	3-DH5	hopping	Ant1	5.15	27	6.15	20	Pass

Test Graphs  
Power NVNT 1-DH5 2402MHz Ant1

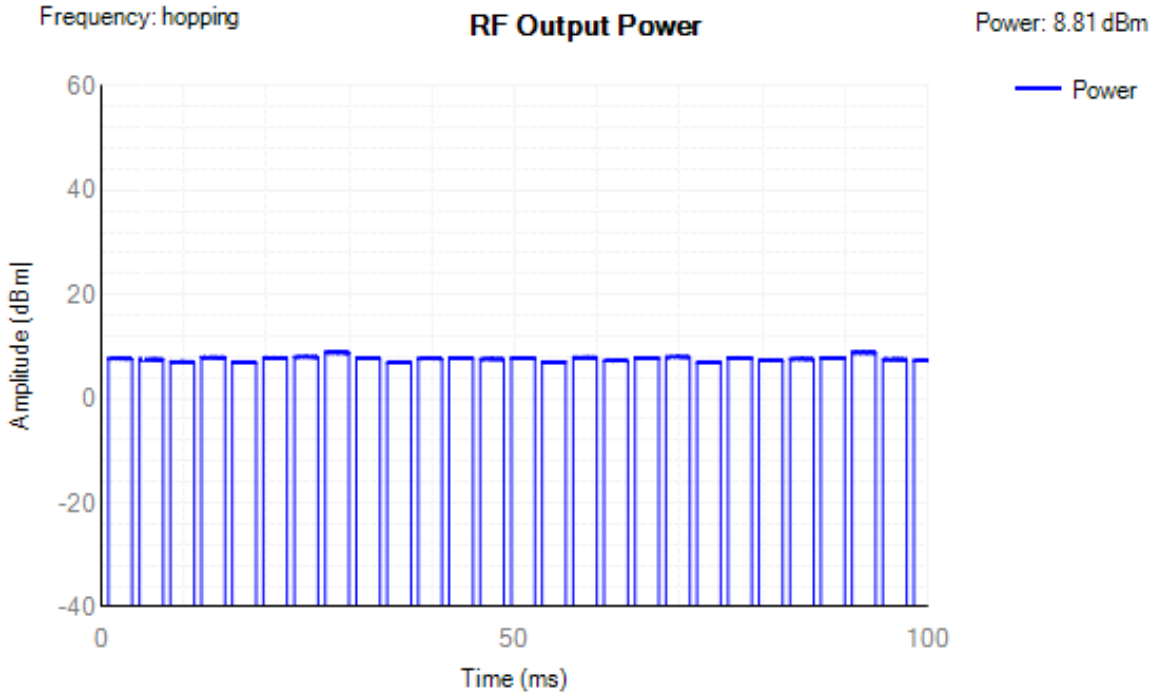

Power NVNT 2-DH5 2402MHz Ant1

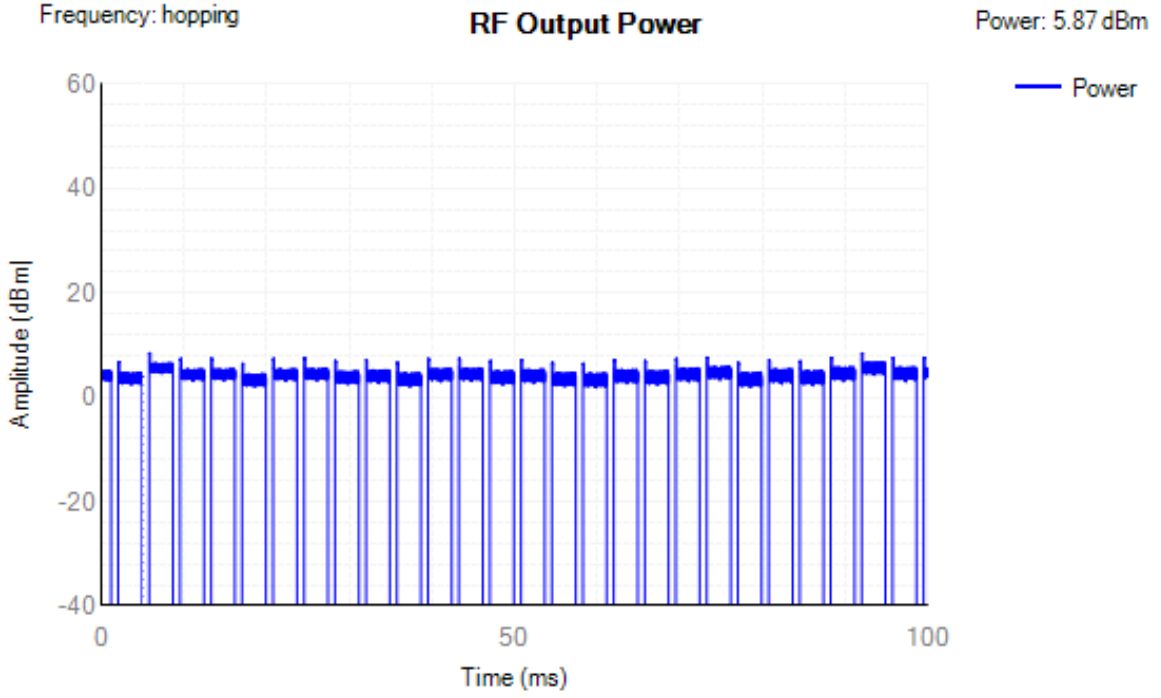

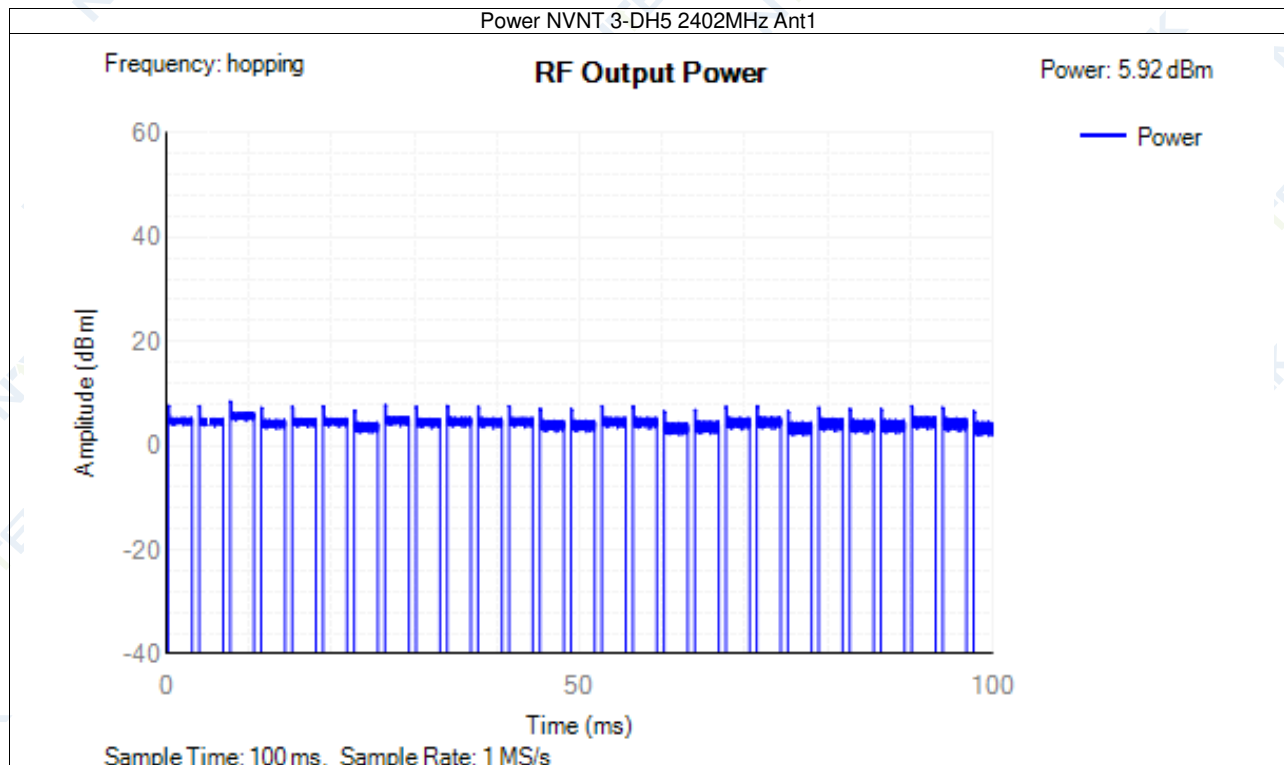

### 11.5 Hopping Frequency Separation

Condition	Mode	Antenna	Hopping Freq1 (MHz)	Hopping Freq2 (MHz)	HFS (MHz)	Limit (MHz)	Verdict
NVNT	1-DH5	Ant1	2401.981	2403.013	1.032	0.1	Pass
NVNT	1-DH5	Ant1	2440.988	2442.011	1.023	0.1	Pass
NVNT	1-DH5	Ant1	2479.004	2479.987	0.983	0.1	Pass
NVNT	2-DH5	Ant1	2401.996	2402.998	1.002	0.1	Pass
NVNT	2-DH5	Ant1	2440.988	2441.998	1.01	0.1	Pass
NVNT	2-DH5	Ant1	2479.085	2480.064	0.979	0.1	Pass
NVNT	3-DH5	Ant1	2402.052	2402.974	0.922	0.1	Pass
NVNT	3-DH5	Ant1	2440.991	2441.985	0.994	0.1	Pass
NVNT	3-DH5	Ant1	2478.991	2479.995	1.004	0.1	Pass



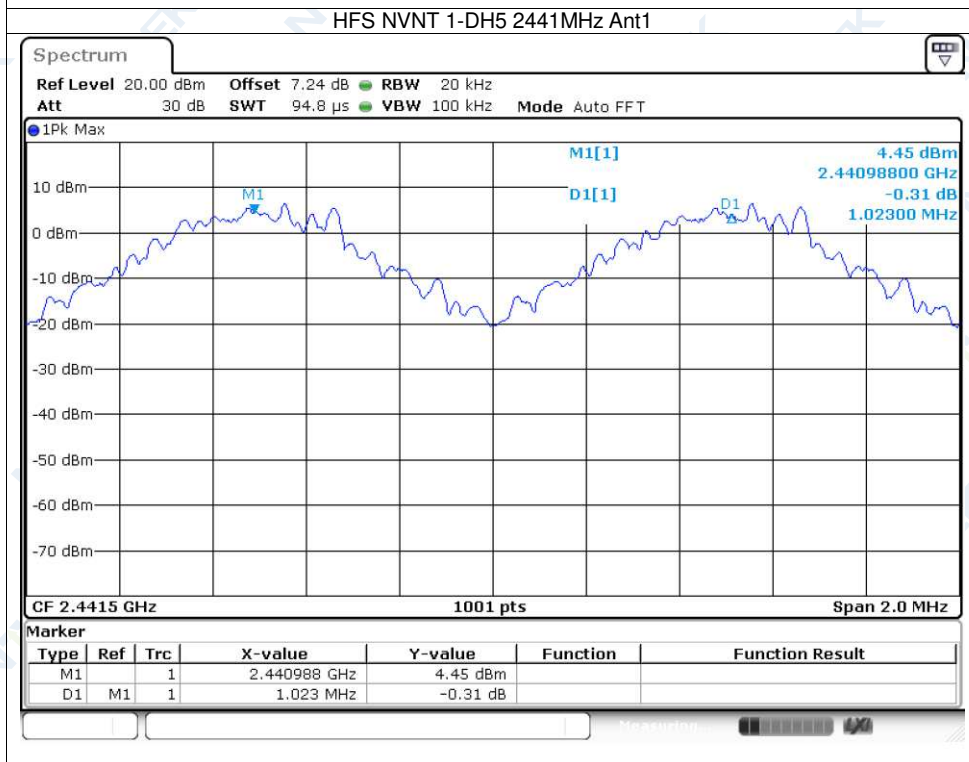
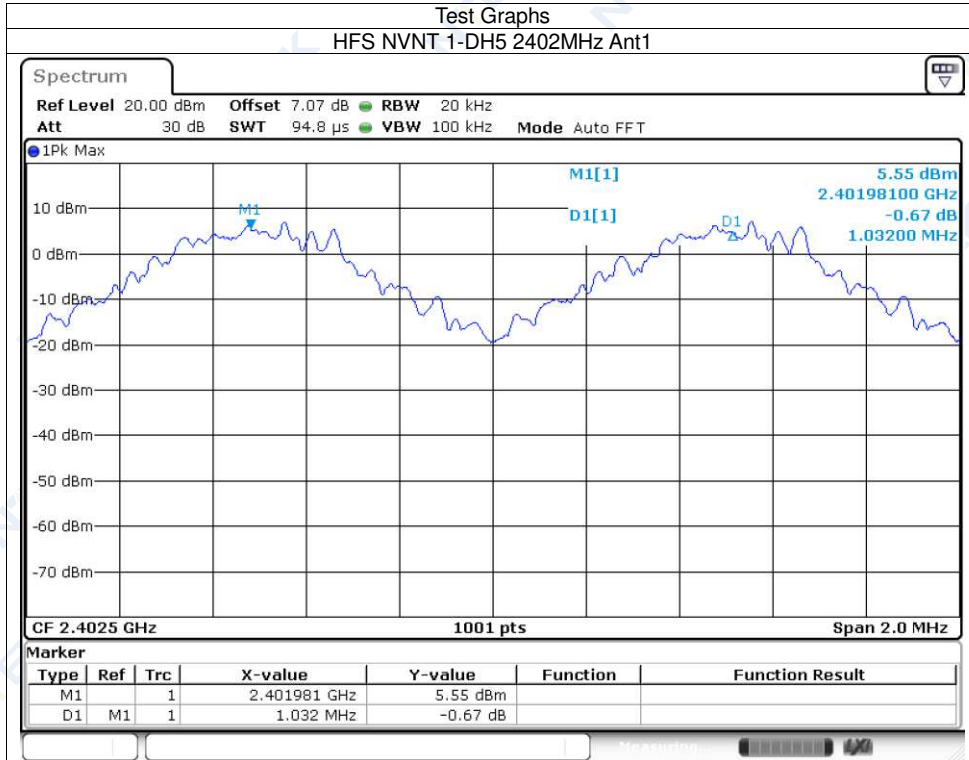



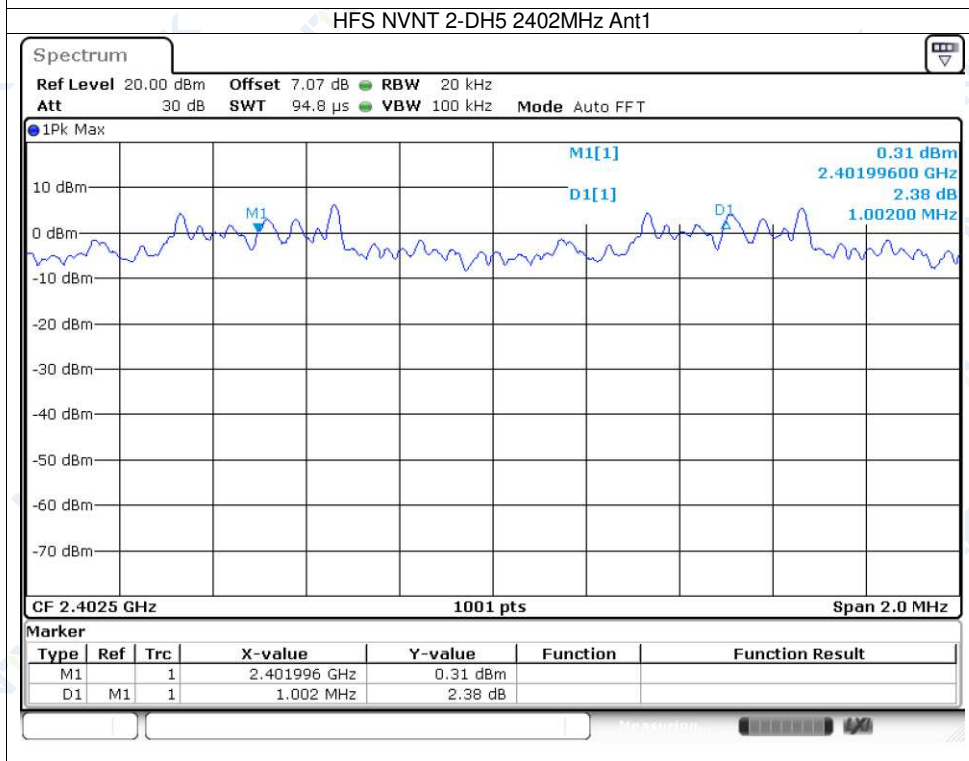
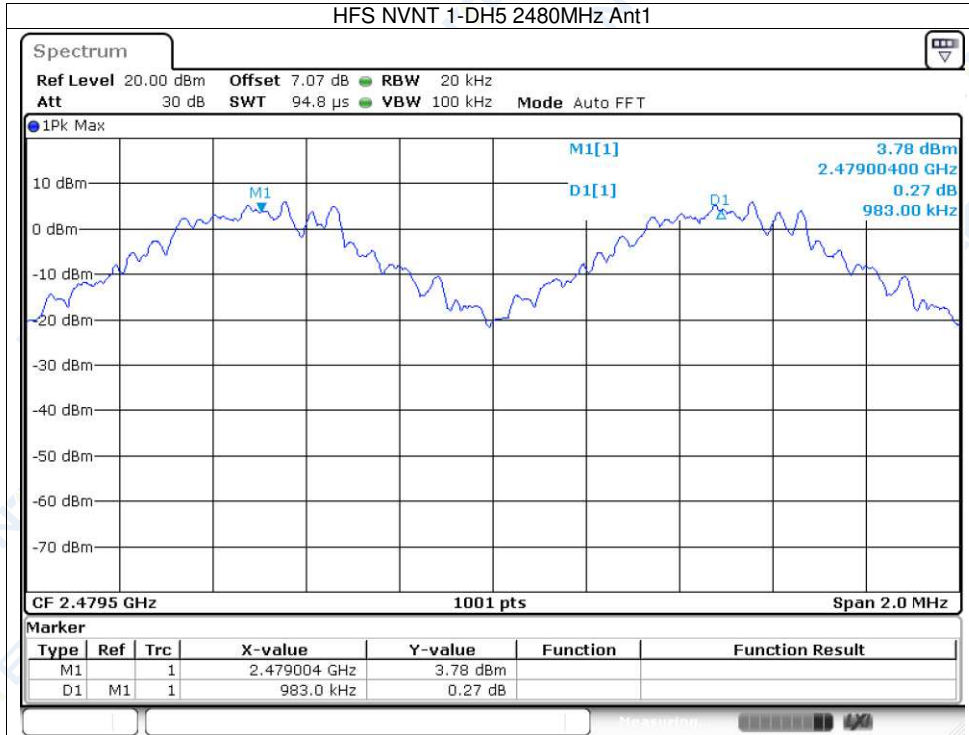

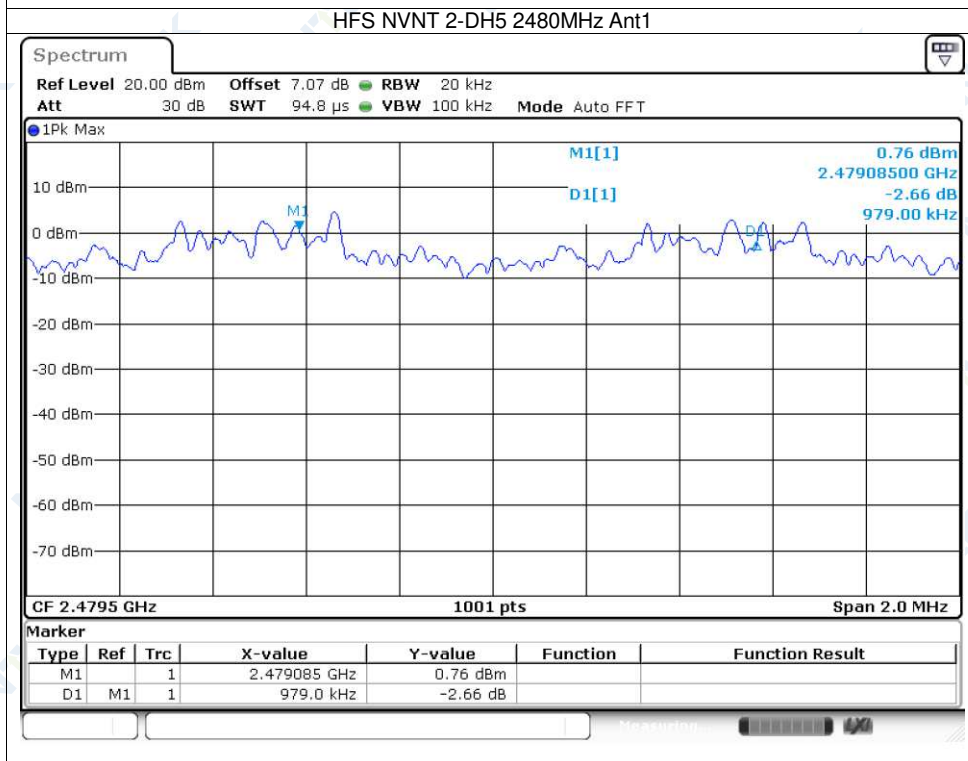
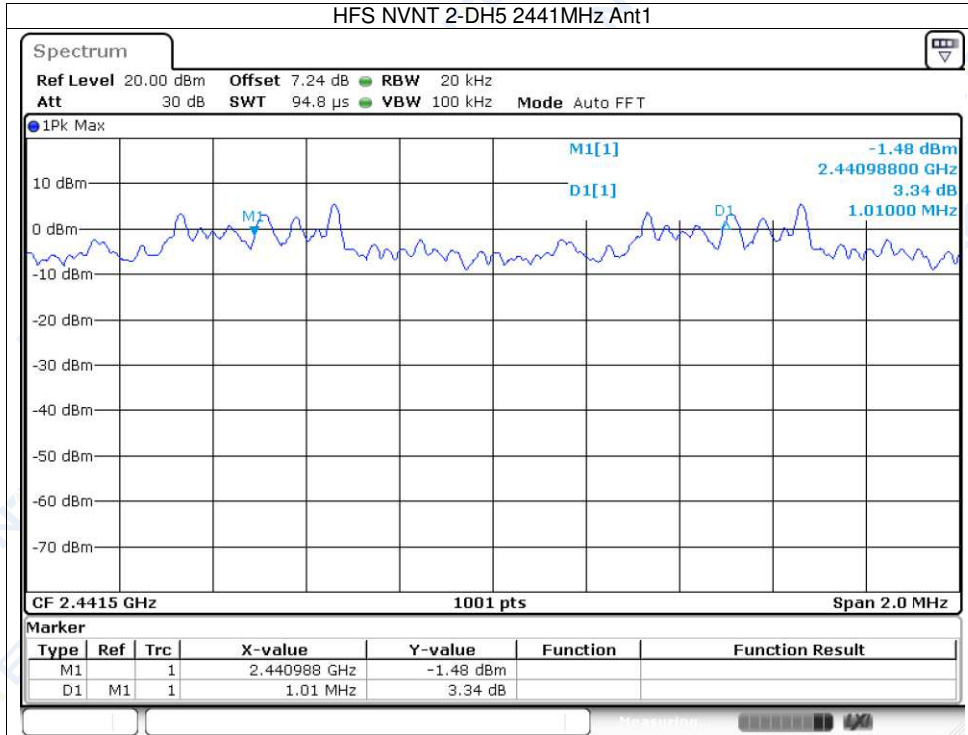

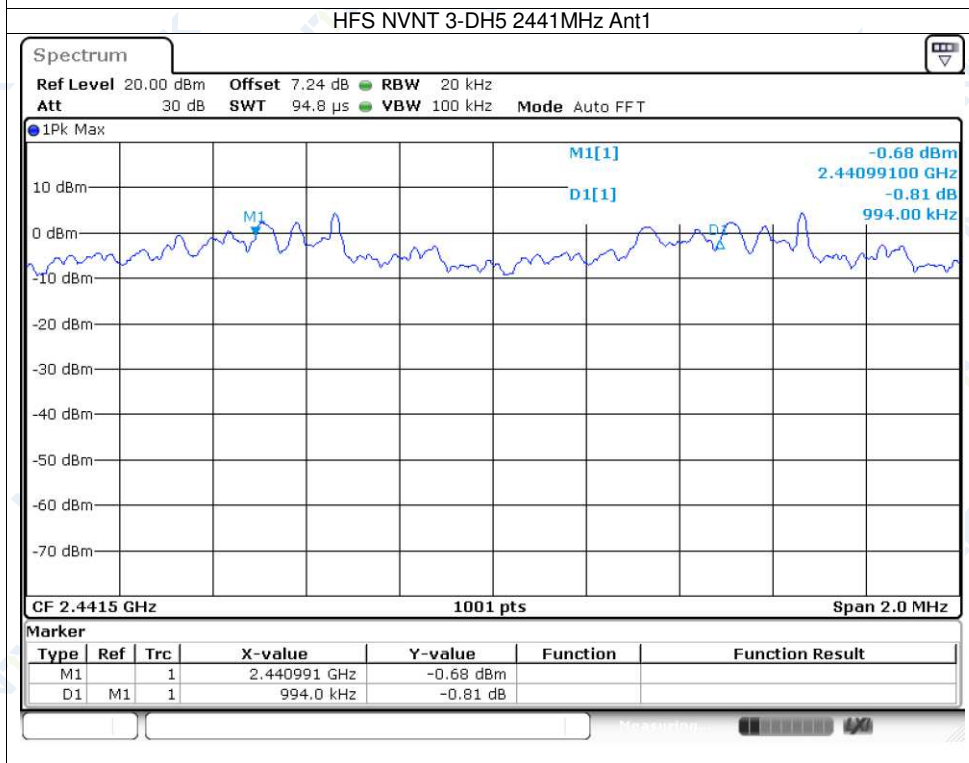
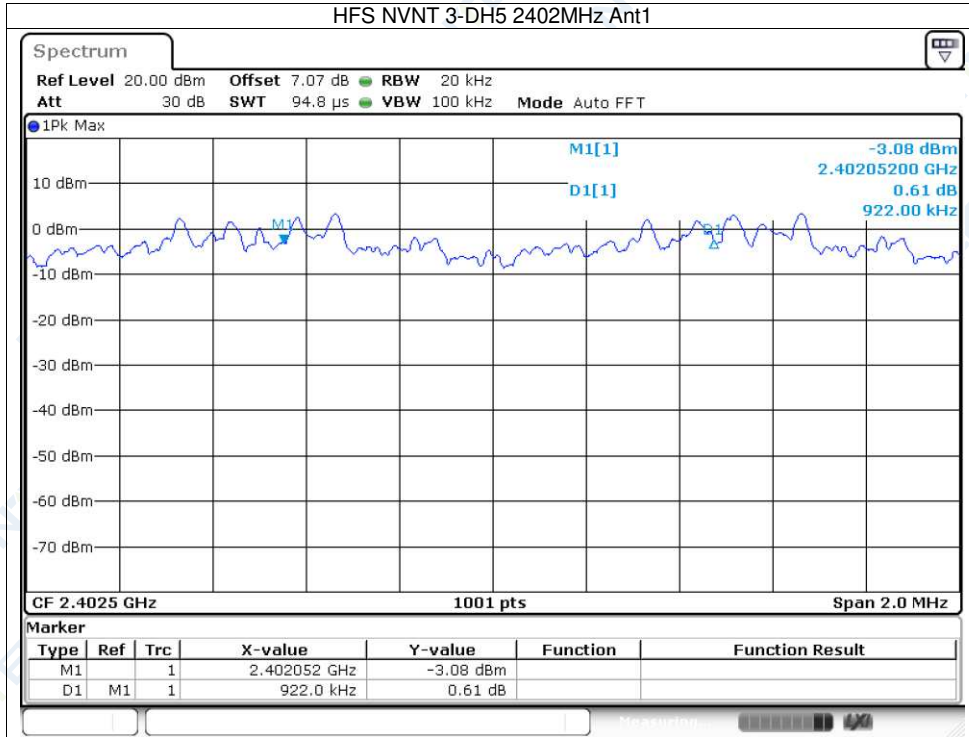

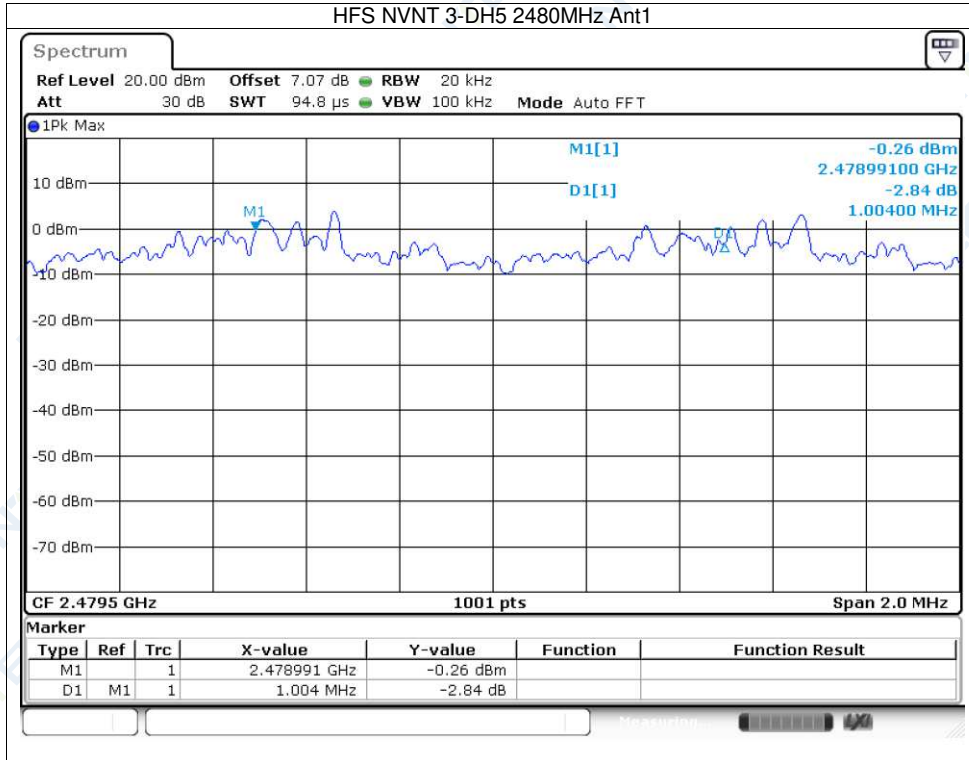

11.6 Occupied Channel Bandwidth

Condition	Mode	Frequency (MHz)	Antenna	Center Frequency (MHz)	OBW (MHz)	Lower Edge (MHz)	Upper Edge (MHz)	Limit OBW (MHz)	Verdict
NVNT	1-DH5	2402	Ant1	2401.999	0.764	2401.617	2402.381	2400 - 2483.5MHz	Pass
NVNT	1-DH5	2480	Ant1	2479.996	0.767	2479.613	2480.38	2400 - 2483.5MHz	Pass
NVNT	2-DH5	2402	Ant1	2401.992	1.17	2401.407	2402.577	2400 - 2483.5MHz	Pass
NVNT	2-DH5	2480	Ant1	2479.992	1.17	2479.407	2480.577	2400 - 2483.5MHz	Pass
NVNT	3-DH5	2402	Ant1	2401.995	1.169	2401.41	2402.579	2400 - 2483.5MHz	Pass
NVNT	3-DH5	2480	Ant1	2479.994	1.163	2479.413	2480.575	2400 - 2483.5MHz	Pass

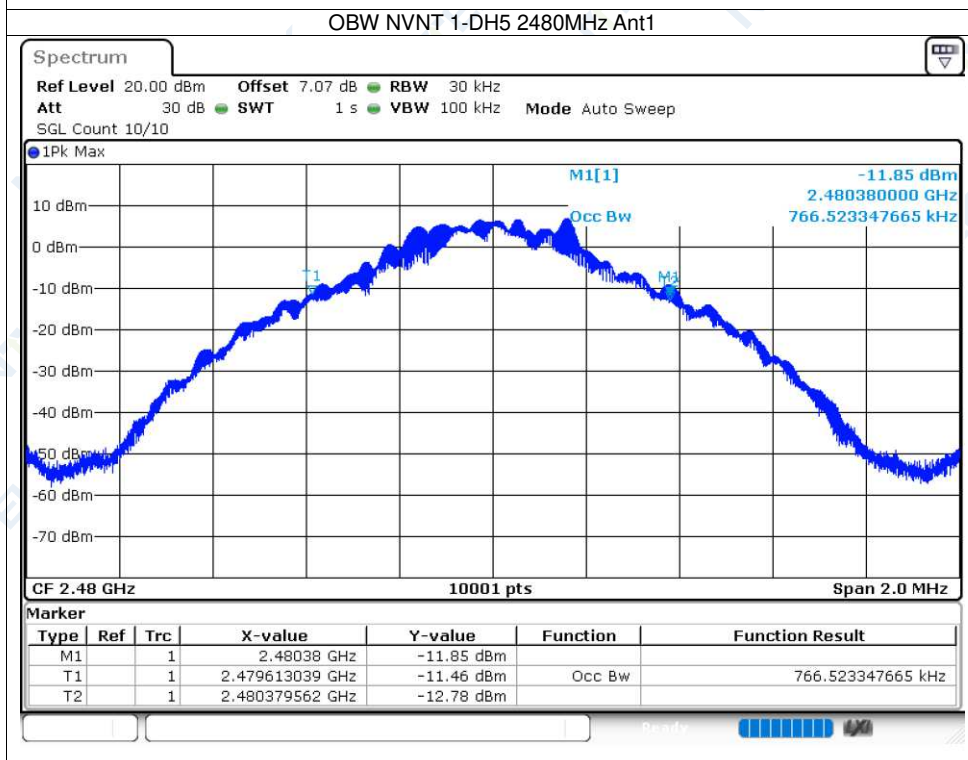
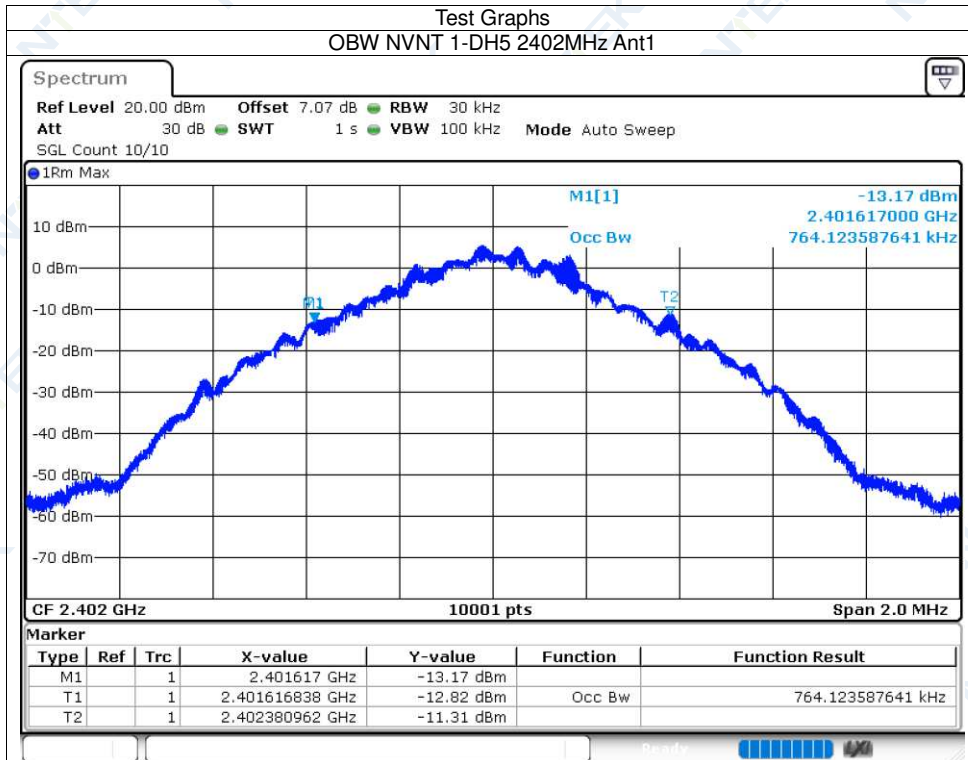



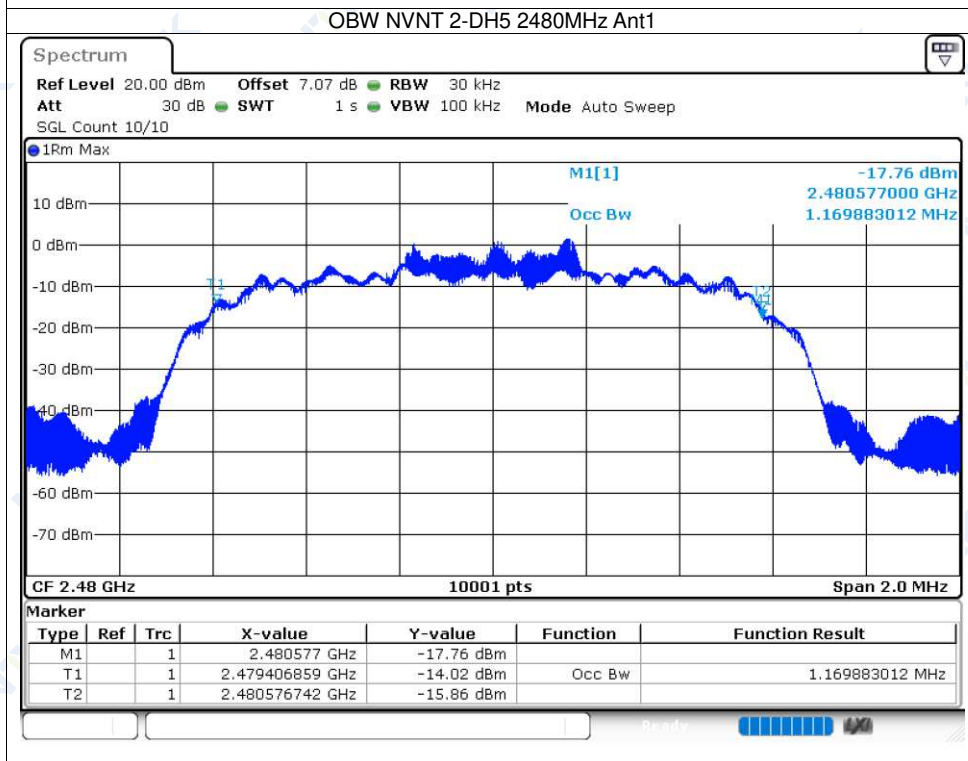
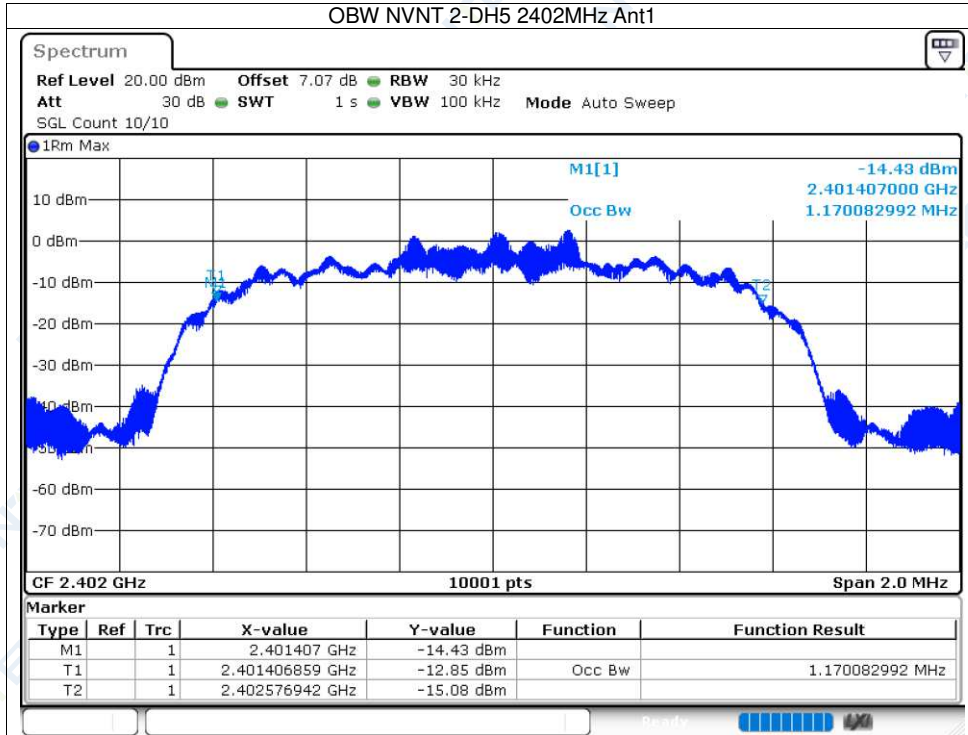

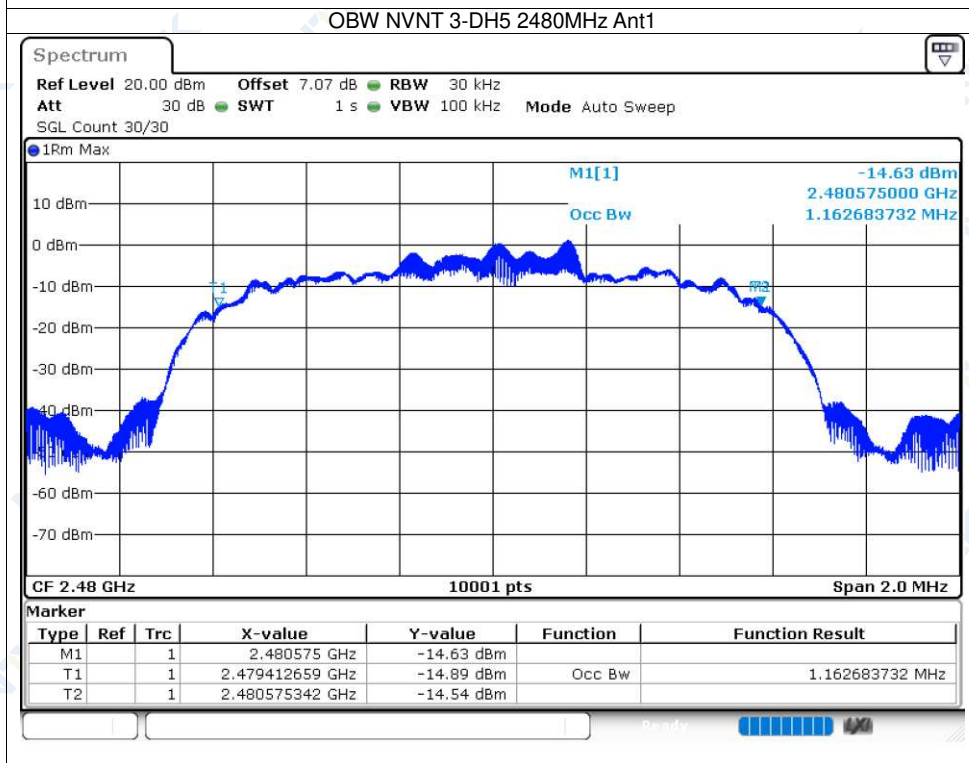
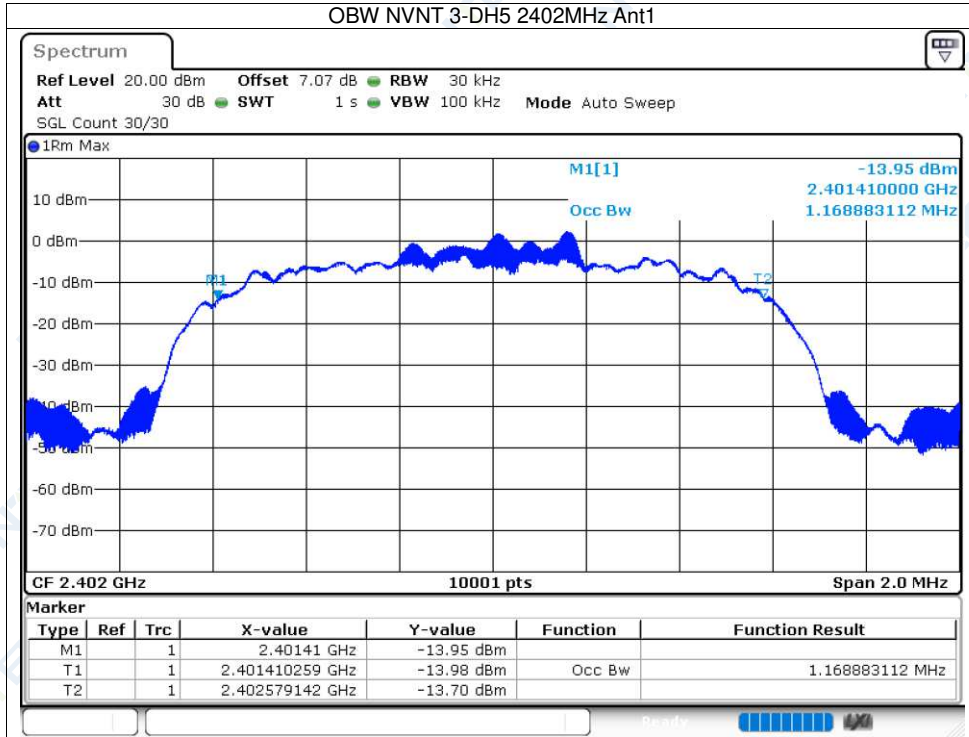



**11.7 Transmitter unwanted emissions in the out-of-band domain**

Condition	Mode	Frequency (MHz)	Antenna	OOB Frequency (MHz)	Level (dBm/MHz)	Limit (dBm/MHz)	Verdict
NVNT	1-DH5	Hopping	Ant1	2399.5	-45.84	-10	Pass
NVNT	1-DH5	Hopping	Ant1	2398.5	-45.31	-20	Pass
NVNT	1-DH5	Hopping	Ant1	2484	-45.02	-10	Pass
NVNT	1-DH5	Hopping	Ant1	2485	-45.12	-20	Pass
NVNT	1-DH5	Hopping	Ant1	2399.5	-45.8	-10	Pass
NVNT	1-DH5	Hopping	Ant1	2398.5	-45.35	-20	Pass
NVNT	1-DH5	Hopping	Ant1	2484	-45.11	-10	Pass
NVNT	2-DH5	Hopping	Ant1	2399.5	-45.71	-10	Pass
NVNT	2-DH5	Hopping	Ant1	2398.5	-45.37	-20	Pass
NVNT	2-DH5	Hopping	Ant1	2484	-45.18	-10	Pass
NVNT	2-DH5	Hopping	Ant1	2485	-45.19	-20	Pass
NVNT	2-DH5	Hopping	Ant1	2399.5	-45.67	-10	Pass
NVNT	2-DH5	Hopping	Ant1	2398.5	-45.38	-20	Pass
NVNT	2-DH5	Hopping	Ant1	2484	-45.16	-10	Pass
NVNT	2-DH5	Hopping	Ant1	2485	-45.17	-20	Pass
NVNT	3-DH5	Hopping	Ant1	2399.5	-45.83	-10	Pass
NVNT	3-DH5	Hopping	Ant1	2398.5	-45.41	-20	Pass
NVNT	3-DH5	Hopping	Ant1	2484	-45.2	-10	Pass
NVNT	3-DH5	Hopping	Ant1	2485	-45.17	-20	Pass
NVNT	3-DH5	Hopping	Ant1	2399.5	-45.81	-10	Pass
NVNT	3-DH5	Hopping	Ant1	2398.5	-45.45	-20	Pass
NVNT	3-DH5	Hopping	Ant1	2484	-45.23	-10	Pass
NVNT	3-DH5	Hopping	Ant1	2484.561	-45.23	-10	Pass
NVNT	3-DH5	Hopping	Ant1	2485.561	-45.37	-20	Pass
NVNT	3-DH5	Hopping	Ant1	2486.122	-45.25	-20	Pass

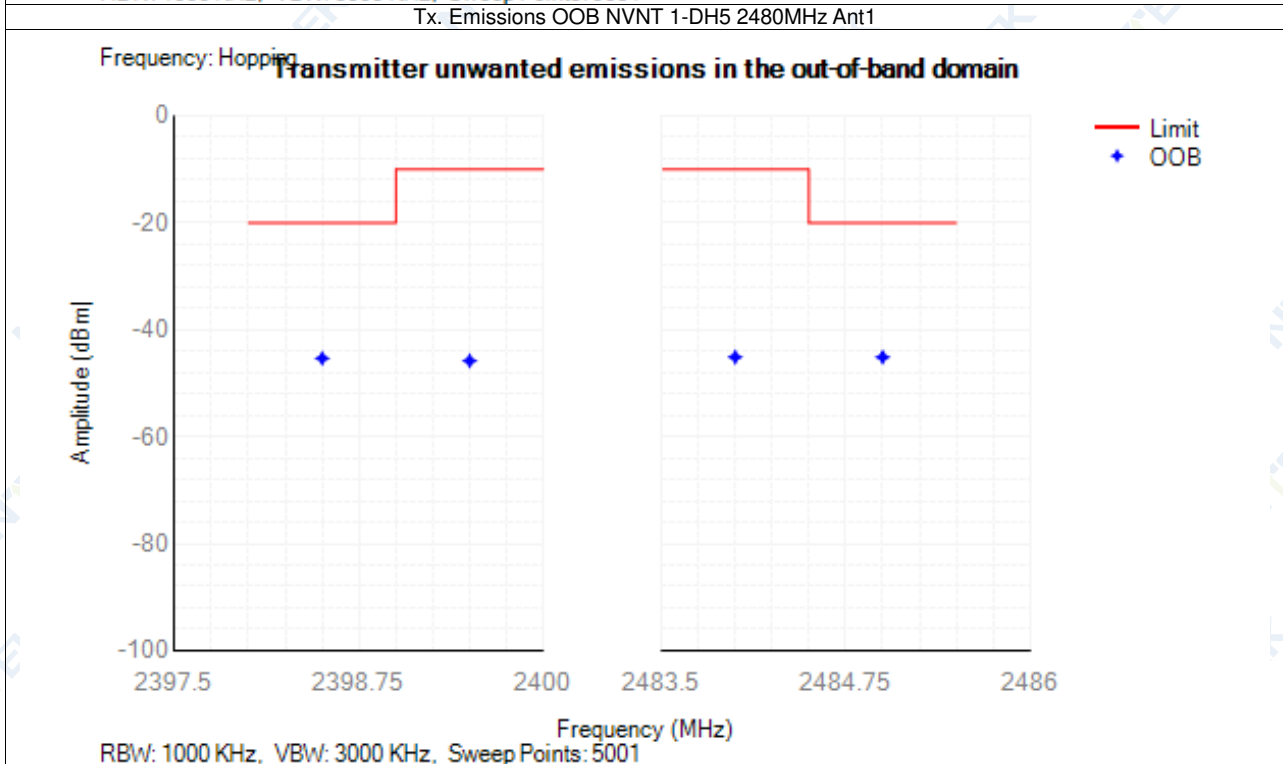
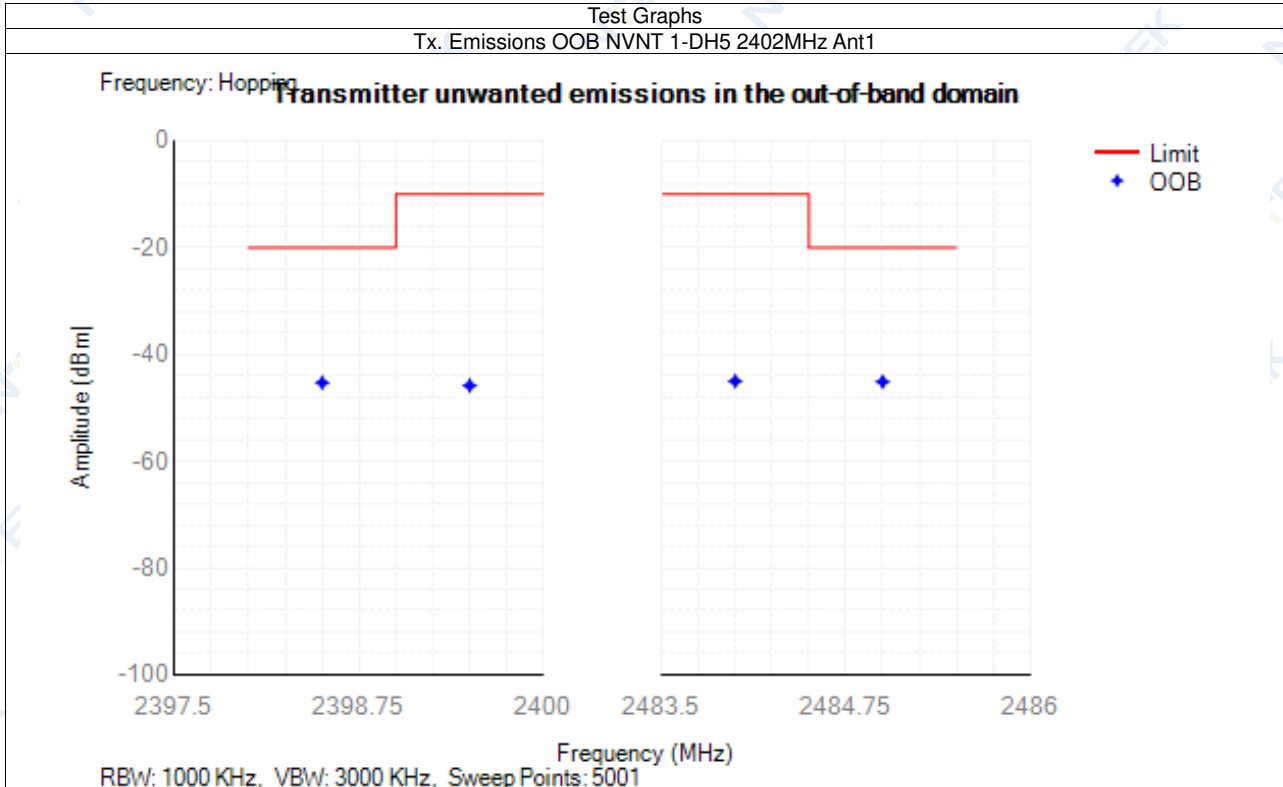

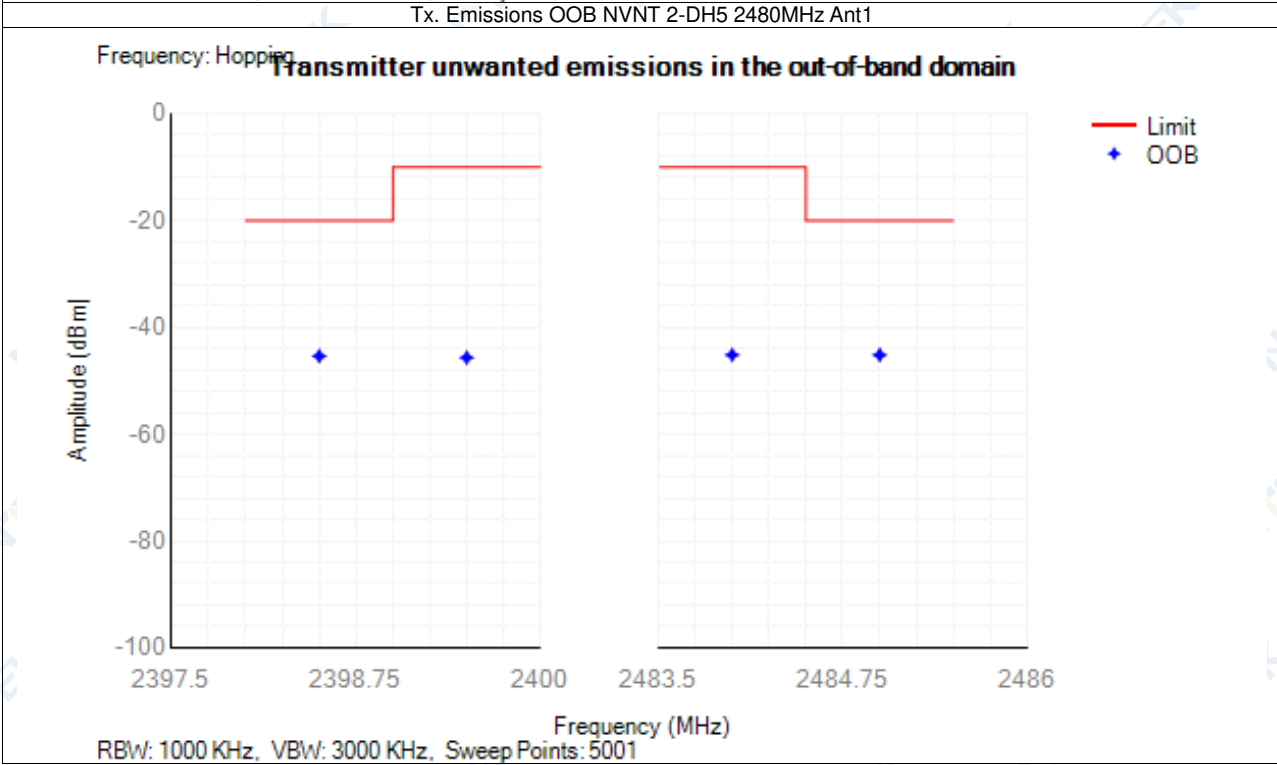
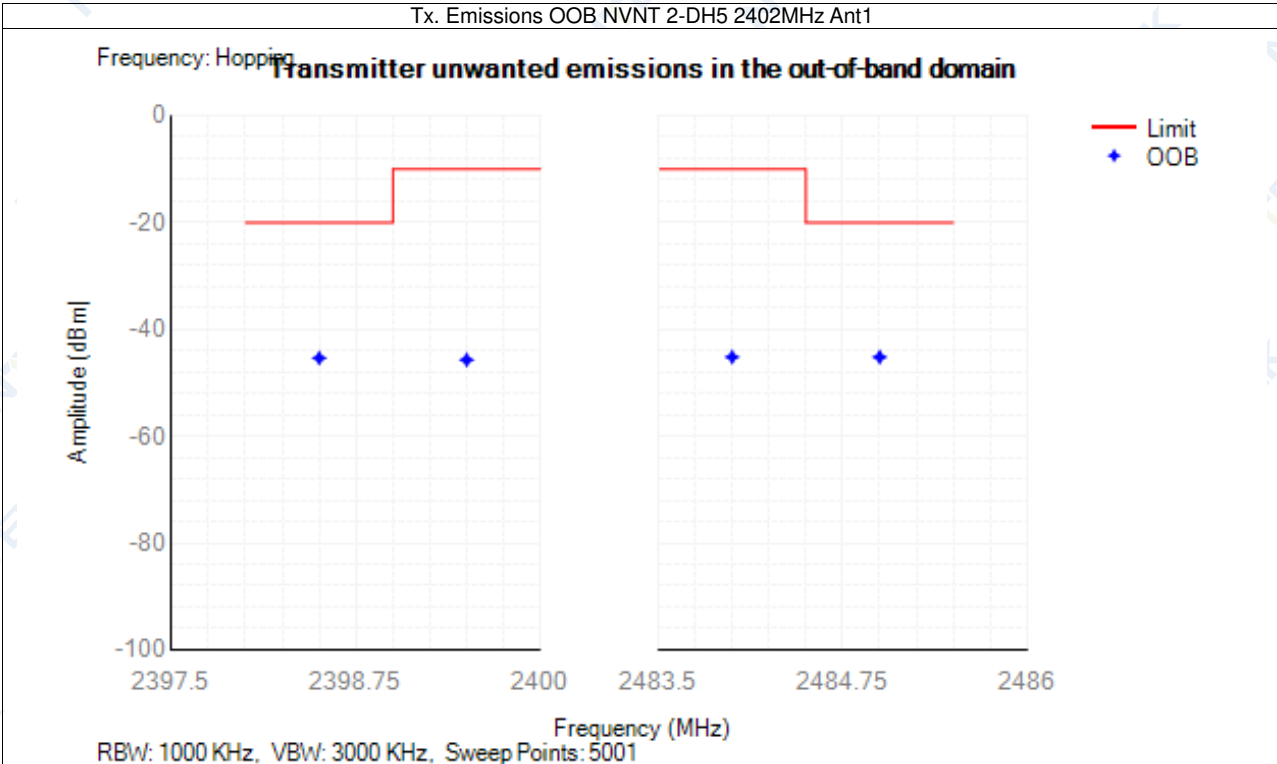

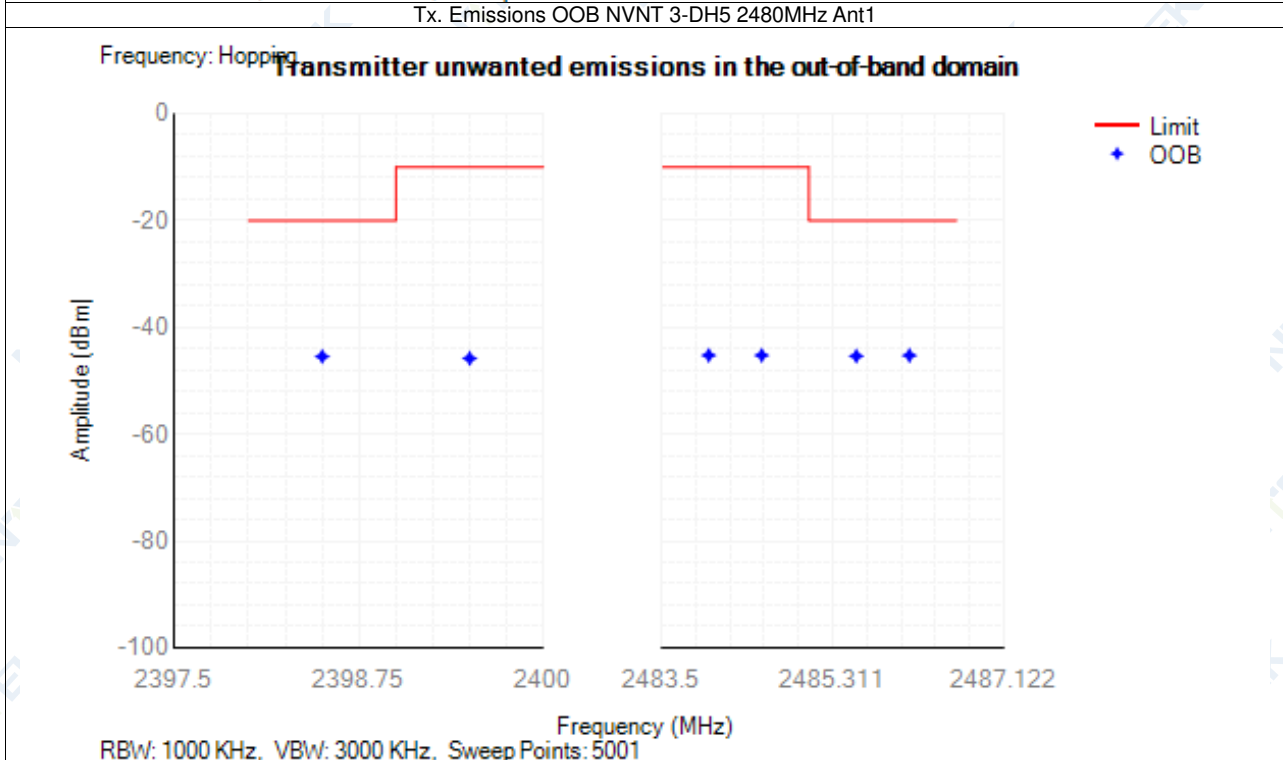
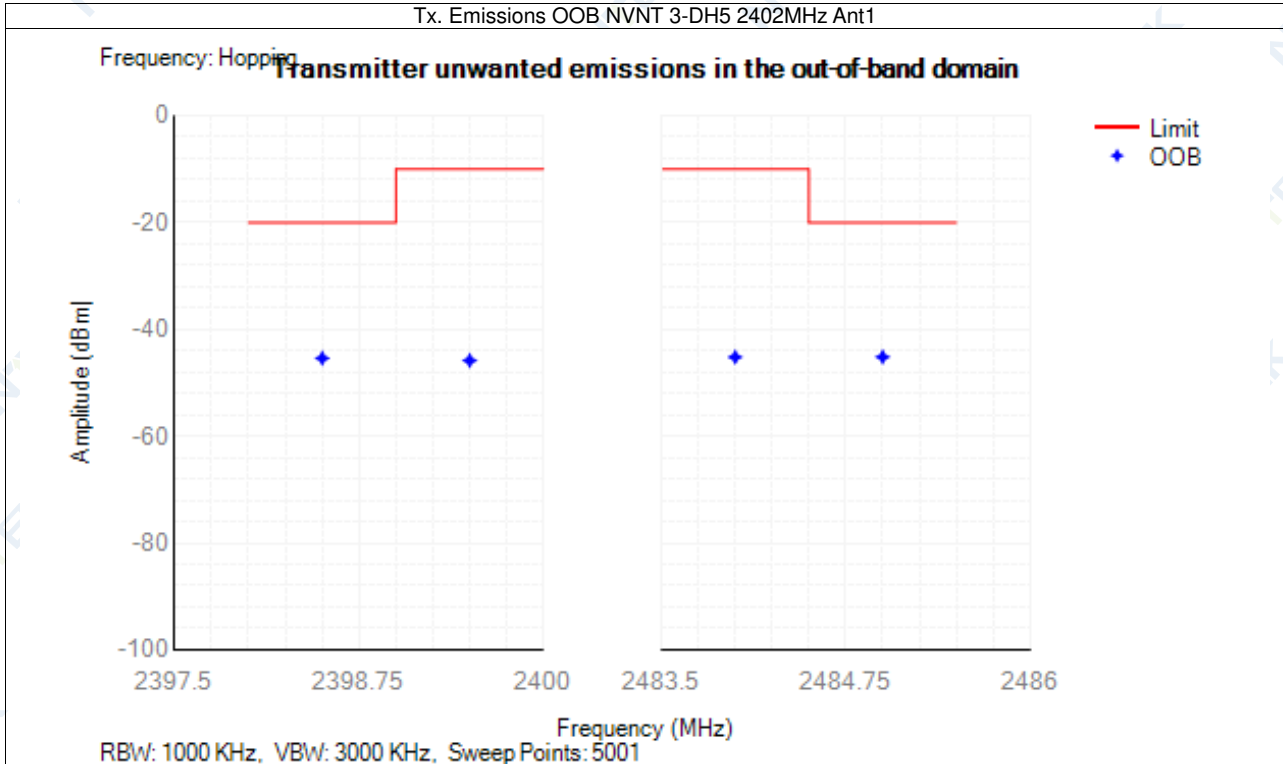

### 11.8 Transmitter unwanted emissions in the spurious domain

Condition	Mode	Frequency (MHz)	Antenna	Range (MHz)	Spur Freq (MHz)	Peak (dBm)	RMS (dBm)	Limit (dBm)	Verdict
NVNT	1-DH5	2402	Ant1	30 -47	37.70	-76.63	NA	-36	Pass
NVNT	1-DH5	2402	Ant1	47 -74	68.90	-76.55	NA	-54	Pass
NVNT	1-DH5	2402	Ant1	74 -87.5	85.20	-76.55	NA	-36	Pass
NVNT	1-DH5	2402	Ant1	87.5 -118	115.75	-76.50	NA	-54	Pass
NVNT	1-DH5	2402	Ant1	118 -174	131.55	-75.43	NA	-36	Pass
NVNT	1-DH5	2402	Ant1	174 -230	229.30	-74.73	NA	-54	Pass
NVNT	1-DH5	2402	Ant1	230 -470	246.40	-74.60	NA	-36	Pass
NVNT	1-DH5	2402	Ant1	470 -694	567.00	-73.30	NA	-54	Pass
NVNT	1-DH5	2402	Ant1	694 -1000	945.75	-67.58	NA	-36	Pass
NVNT	1-DH5	2402	Ant1	1000 -2398	2397.50	-50.00	NA	-30	Pass
NVNT	1-DH5	2402	Ant1	2485.5 -12750	7206.00	-40.75	NA	-30	Pass
NVNT	1-DH5	2441	Ant1	30 -47	46.15	-74.80	NA	-36	Pass
NVNT	1-DH5	2441	Ant1	47 -74	53.15	-75.85	NA	-54	Pass
NVNT	1-DH5	2441	Ant1	74 -87.5	76.75	-75.46	NA	-36	Pass
NVNT	1-DH5	2441	Ant1	87.5 -118	95.35	-75.89	NA	-54	Pass
NVNT	1-DH5	2441	Ant1	118 -174	153.55	-73.58	NA	-36	Pass
NVNT	1-DH5	2441	Ant1	174 -230	223.35	-74.12	NA	-54	Pass
NVNT	1-DH5	2441	Ant1	230 -470	372.00	-74.04	NA	-36	Pass
NVNT	1-DH5	2441	Ant1	470 -694	646.90	-73.70	NA	-54	Pass
NVNT	1-DH5	2441	Ant1	694 -1000	948.20	-61.51	NA	-36	Pass
NVNT	1-DH5	2441	Ant1	1000 -2398	2397.50	-52.15	NA	-30	Pass
NVNT	1-DH5	2441	Ant1	2485.5 -12750	7323.00	-41.23	NA	-30	Pass
NVNT	1-DH5	2480	Ant1	30 -47	44.50	-75.80	NA	-36	Pass
NVNT	1-DH5	2480	Ant1	47 -74	73.15	-75.37	NA	-54	Pass
NVNT	1-DH5	2480	Ant1	74 -87.5	83.40	-76.14	NA	-36	Pass
NVNT	1-DH5	2480	Ant1	87.5 -118	108.05	-75.13	NA	-54	Pass
NVNT	1-DH5	2480	Ant1	118 -174	160.75	-75.13	NA	-36	Pass
NVNT	1-DH5	2480	Ant1	174 -230	216.45	-74.41	NA	-54	Pass
NVNT	1-DH5	2480	Ant1	230 -470	353.90	-74.19	NA	-36	Pass
NVNT	1-DH5	2480	Ant1	470 -694	648.00	-73.91	NA	-54	Pass
NVNT	1-DH5	2480	Ant1	694 -1000	948.20	-59.10	NA	-36	Pass
NVNT	1-DH5	2480	Ant1	1000 -2398	2058.50	-52.13	NA	-30	Pass
NVNT	1-DH5	2480	Ant1	2485.5 -12750	7440.00	-40.35	NA	-30	Pass
NVNT	2-DH5	2402	Ant1	30 -47	31.10	-75.36	NA	-36	Pass
NVNT	2-DH5	2402	Ant1	47 -74	53.65	-75.70	NA	-54	Pass
NVNT	2-DH5	2402	Ant1	74 -87.5	79.90	-75.39	NA	-36	Pass
NVNT	2-DH5	2402	Ant1	87.5 -118	106.60	-75.44	NA	-54	Pass
NVNT	2-DH5	2402	Ant1	118 -174	120.75	-74.57	NA	-36	Pass
NVNT	2-DH5	2402	Ant1	174 -230	224.85	-75.13	NA	-54	Pass
NVNT	2-DH5	2402	Ant1	230 -470	347.20	-74.65	NA	-36	Pass
NVNT	2-DH5	2402	Ant1	470 -694	630.25	-73.29	NA	-54	Pass
NVNT	2-DH5	2402	Ant1	694 -1000	948.15	-62.22	NA	-36	Pass
NVNT	2-DH5	2402	Ant1	1000 -2398	2395.00	-49.94	NA	-30	Pass
NVNT	2-DH5	2402	Ant1	2485.5 -12750	7206.50	-43.95	NA	-30	Pass
NVNT	2-DH5	2441	Ant1	30 -47	44.95	-75.63	NA	-36	Pass
NVNT	2-DH5	2441	Ant1	47 -74	56.40	-75.71	NA	-54	Pass
NVNT	2-DH5	2441	Ant1	74 -87.5	80.55	-75.76	NA	-36	Pass
NVNT	2-DH5	2441	Ant1	87.5 -118	101.40	-75.82	NA	-54	Pass
NVNT	2-DH5	2441	Ant1	118 -174	143.15	-74.96	NA	-36	Pass
NVNT	2-DH5	2441	Ant1	174 -230	197.15	-75.24	NA	-54	Pass
NVNT	2-DH5	2441	Ant1	230 -470	334.40	-73.95	NA	-36	Pass
NVNT	2-DH5	2441	Ant1	470 -694	616.00	-74.17	NA	-54	Pass
NVNT	2-DH5	2441	Ant1	694 -1000	948.30	-62.44	NA	-36	Pass
NVNT	2-DH5	2441	Ant1	1000 -2398	2381.00	-53.01	NA	-30	Pass
NVNT	2-DH5	2441	Ant1	2485.5 -12750	6910.00	-44.15	NA	-30	Pass
NVNT	2-DH5	2480	Ant1	30 -47	35.05	-75.88	NA	-36	Pass
NVNT	2-DH5	2480	Ant1	47 -74	56.70	-75.71	NA	-54	Pass
NVNT	2-DH5	2480	Ant1	74 -87.5	84.80	-75.22	NA	-36	Pass
NVNT	2-DH5	2480	Ant1	87.5 -118	113.60	-75.30	NA	-54	Pass
NVNT	2-DH5	2480	Ant1	118 -174	130.65	-75.01	NA	-36	Pass
NVNT	2-DH5	2480	Ant1	174 -230	189.30	-74.92	NA	-54	Pass
NVNT	2-DH5	2480	Ant1	230 -470	398.20	-74.00	NA	-36	Pass
NVNT	2-DH5	2480	Ant1	470 -694	575.40	-74.22	NA	-54	Pass
NVNT	2-DH5	2480	Ant1	694 -1000	948.25	-63.29	NA	-36	Pass
NVNT	2-DH5	2480	Ant1	1000 -2398	2086.00	-52.97	NA	-30	Pass
NVNT	2-DH5	2480	Ant1	2485.5 -12750	7440.50	-40.94	NA	-30	Pass
NVNT	3-DH5	2402	Ant1	30 -47	35.55	-76.00	NA	-36	Pass
NVNT	3-DH5	2402	Ant1	47 -74	66.90	-75.73	NA	-54	Pass
NVNT	3-DH5	2402	Ant1	74 -87.5	78.25	-76.83	NA	-36	Pass
NVNT	3-DH5	2402	Ant1	87.5 -118	117.70	-75.17	NA	-54	Pass
NVNT	3-DH5	2402	Ant1	118 -174	159.95	-75.32	NA	-36	Pass
NVNT	3-DH5	2402	Ant1	174 -230	203.15	-74.97	NA	-54	Pass

NVNT	3-DH5	2402	Ant1	230 -470	257.30	-73.93	NA	-36	Pass
NVNT	3-DH5	2402	Ant1	470 -694	470.10	-74.00	NA	-54	Pass
NVNT	3-DH5	2402	Ant1	694 -1000	948.25	-66.01	NA	-36	Pass
NVNT	3-DH5	2402	Ant1	1000 -2398	2396.50	-50.28	NA	-30	Pass
NVNT	3-DH5	2402	Ant1	2485.5 -12750	7205.50	-40.55	NA	-30	Pass
NVNT	3-DH5	2441	Ant1	30 -47	44.30	-75.92	NA	-36	Pass
NVNT	3-DH5	2441	Ant1	47 -74	65.60	-75.78	NA	-54	Pass
NVNT	3-DH5	2441	Ant1	74 -87.5	75.60	-75.63	NA	-36	Pass
NVNT	3-DH5	2441	Ant1	87.5 -118	99.55	-75.69	NA	-54	Pass
NVNT	3-DH5	2441	Ant1	118 -174	154.90	-75.33	NA	-36	Pass
NVNT	3-DH5	2441	Ant1	174 -230	227.40	-74.54	NA	-54	Pass
NVNT	3-DH5	2441	Ant1	230 -470	281.40	-73.58	NA	-36	Pass
NVNT	3-DH5	2441	Ant1	470 -694	482.05	-74.89	NA	-54	Pass
NVNT	3-DH5	2441	Ant1	694 -1000	948.15	-60.61	NA	-36	Pass
NVNT	3-DH5	2441	Ant1	1000 -2398	1935.00	-52.80	NA	-30	Pass
NVNT	3-DH5	2441	Ant1	2485.5 -12750	7323.00	-43.29	NA	-30	Pass
NVNT	3-DH5	2480	Ant1	30 -47	30.60	-76.49	NA	-36	Pass
NVNT	3-DH5	2480	Ant1	47 -74	58.85	-76.00	NA	-54	Pass
NVNT	3-DH5	2480	Ant1	74 -87.5	86.50	-76.09	NA	-36	Pass
NVNT	3-DH5	2480	Ant1	87.5 -118	89.35	-75.97	NA	-54	Pass
NVNT	3-DH5	2480	Ant1	118 -174	119.00	-75.59	NA	-36	Pass
NVNT	3-DH5	2480	Ant1	174 -230	227.90	-74.73	NA	-54	Pass
NVNT	3-DH5	2480	Ant1	230 -470	331.90	-73.82	NA	-36	Pass
NVNT	3-DH5	2480	Ant1	470 -694	568.00	-74.29	NA	-54	Pass
NVNT	3-DH5	2480	Ant1	694 -1000	948.20	-64.02	NA	-36	Pass
NVNT	3-DH5	2480	Ant1	1000 -2398	2252.50	-52.50	NA	-30	Pass
NVNT	3-DH5	2480	Ant1	2485.5 -12750	7440.00	-40.43	NA	-30	Pass



Test Graphs

Tx. Spurious NVNT 1-DH5 2402MHz Ant1

Frequency: 2402 MHz

Transmitter unwanted emissions in the spurious domain

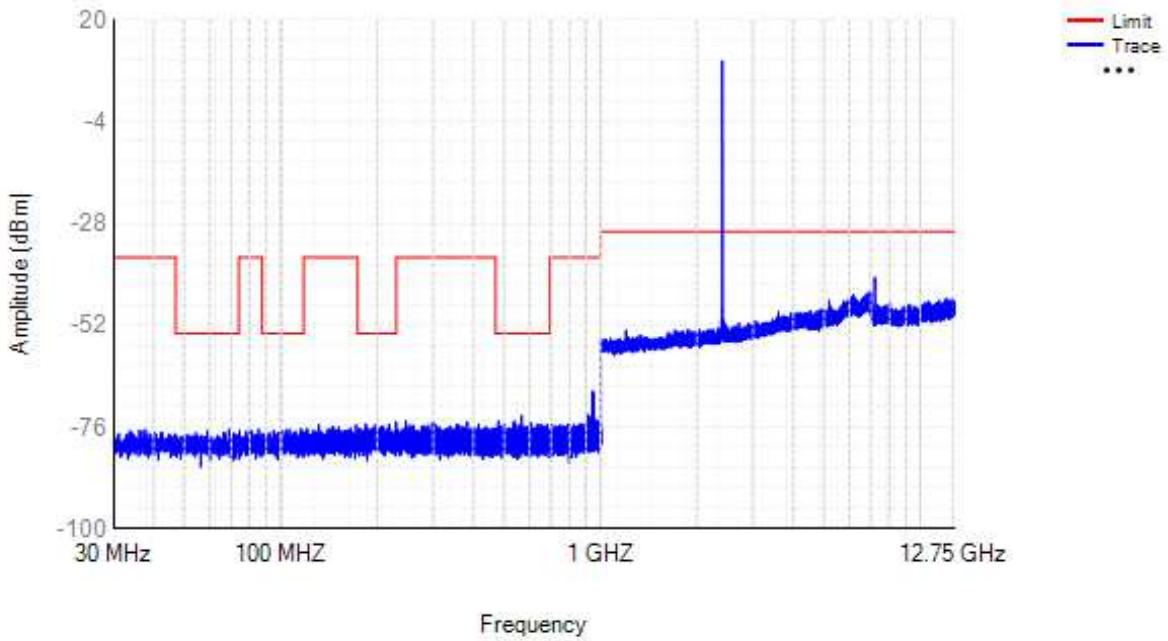

Tx. Spurious NVNT 1-DH5 2441MHz Ant1

Frequency: 2441 MHz

Transmitter unwanted emissions in the spurious domain

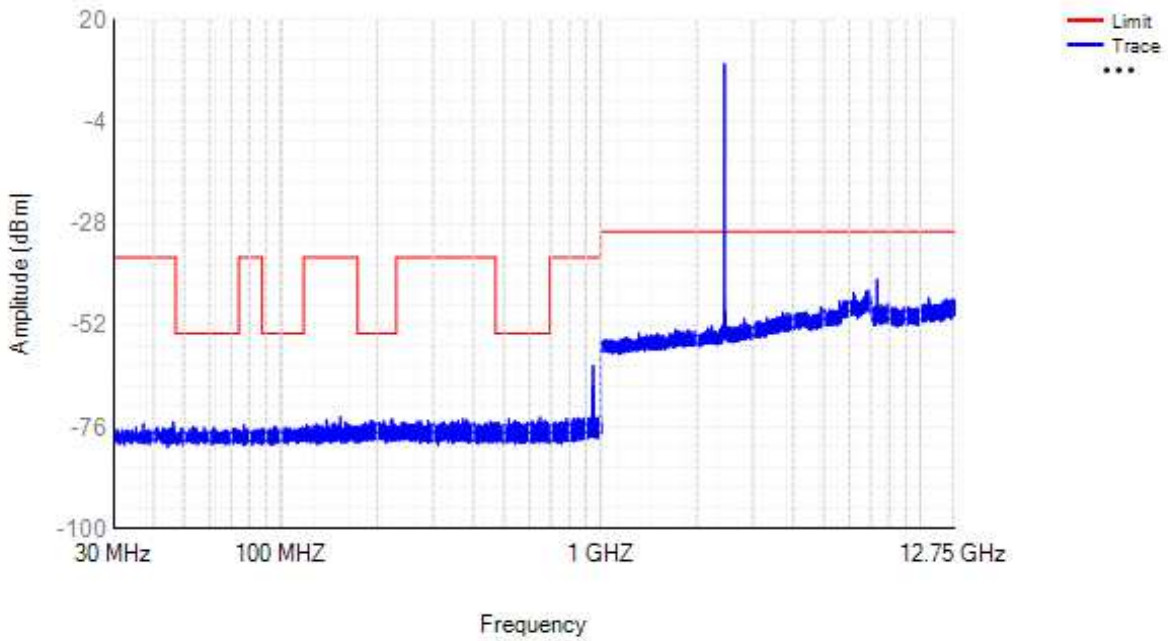



Tx. Spurious NVNT 1-DH5 2480MHz Ant1

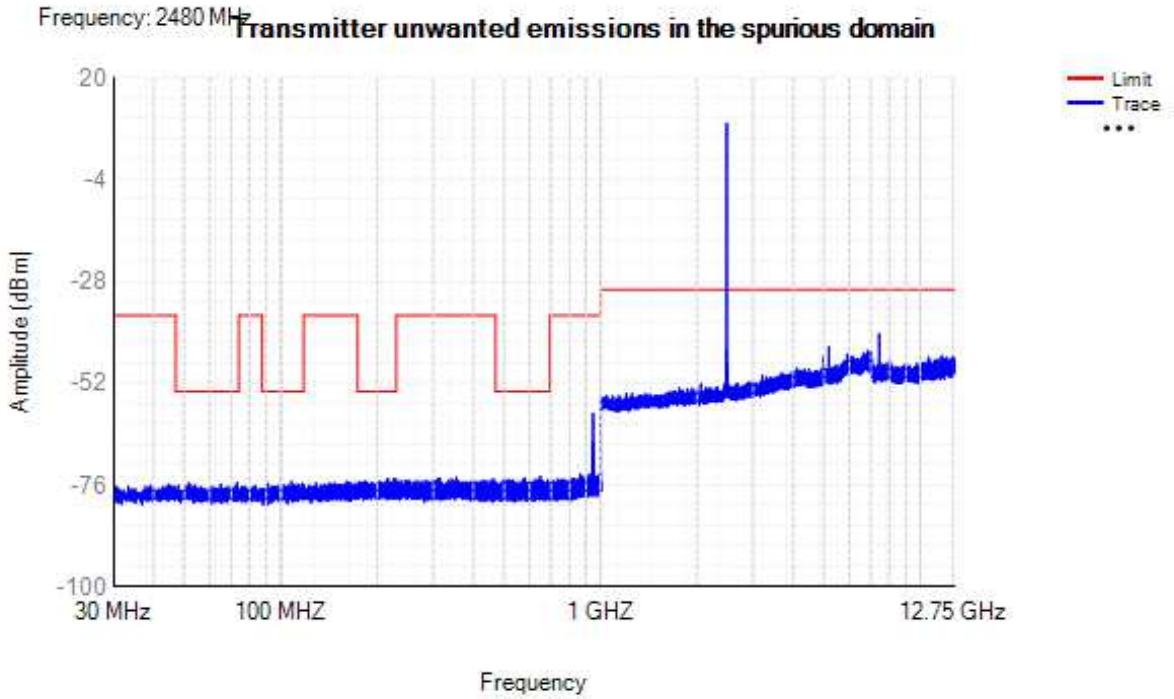

Tx. Spurious NVNT 2-DH5 2402MHz Ant1

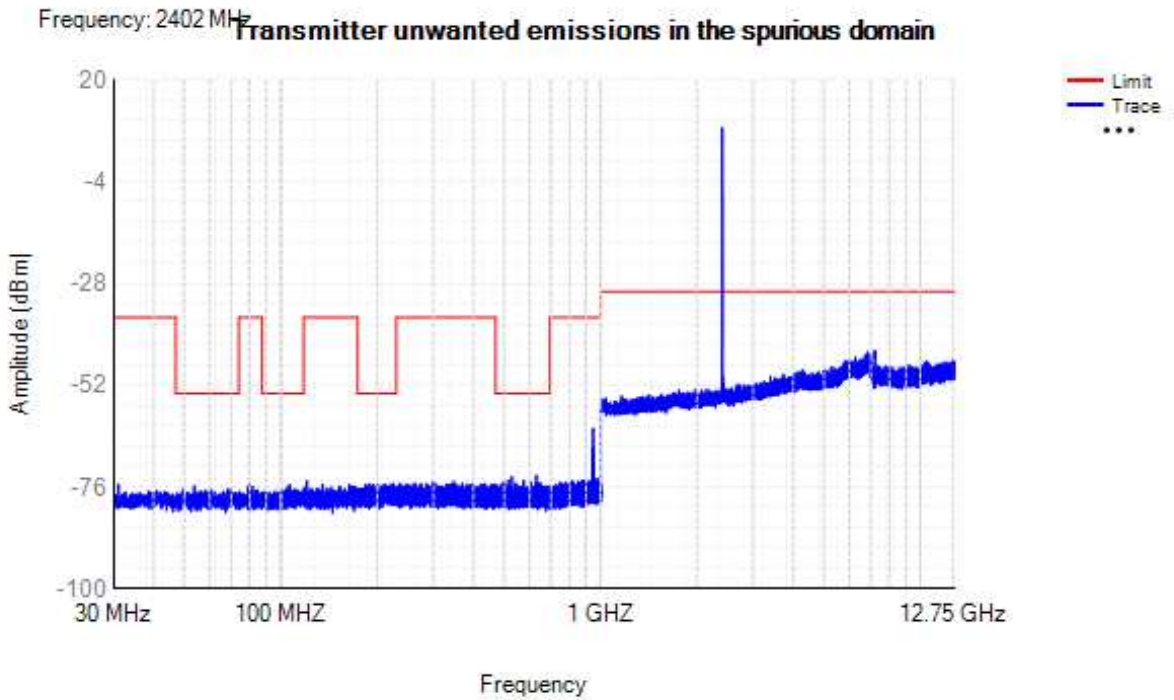

Tx. Spurious NVNT 2-DH5 2441MHz Ant1

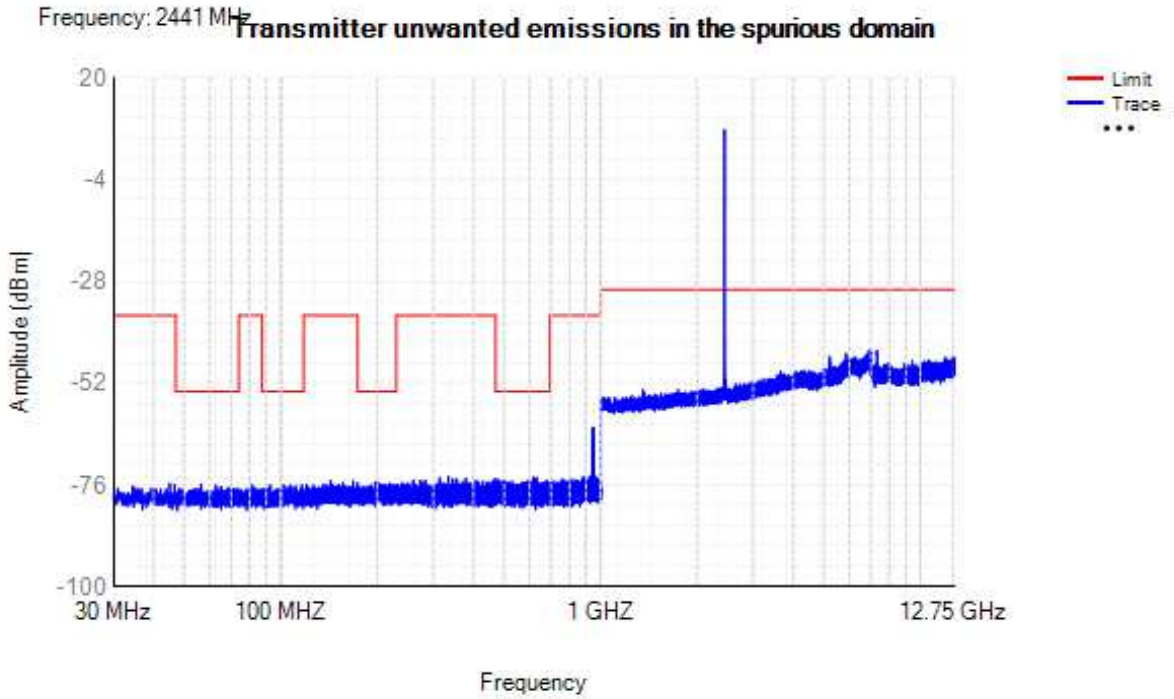

Tx. Spurious NVNT 2-DH5 2480MHz Ant1

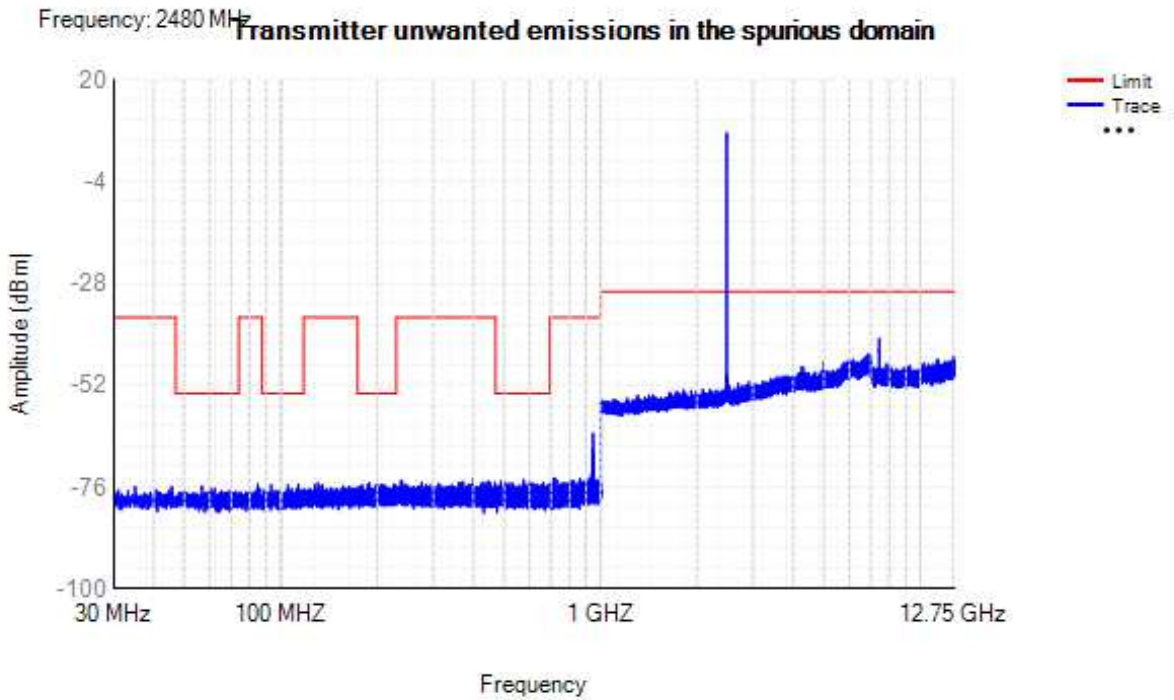

Tx. Spurious NVNT 3-DH5 2402MHz Ant1

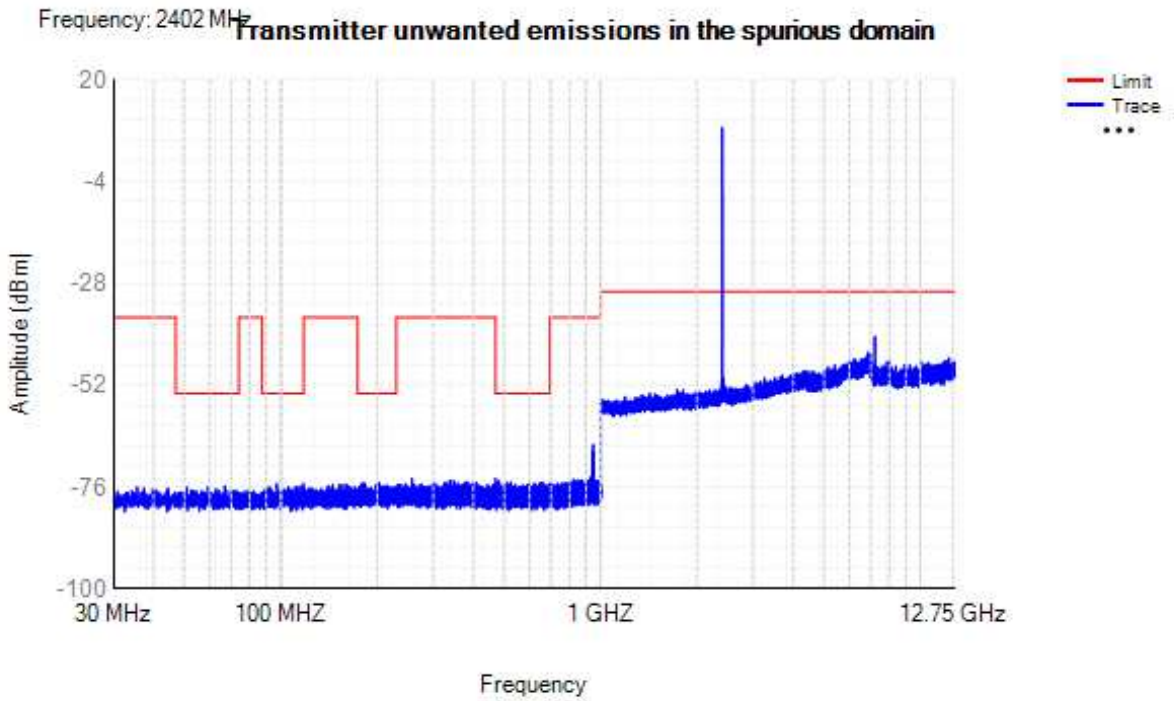

Tx. Spurious NVNT 3-DH5 2441MHz Ant1

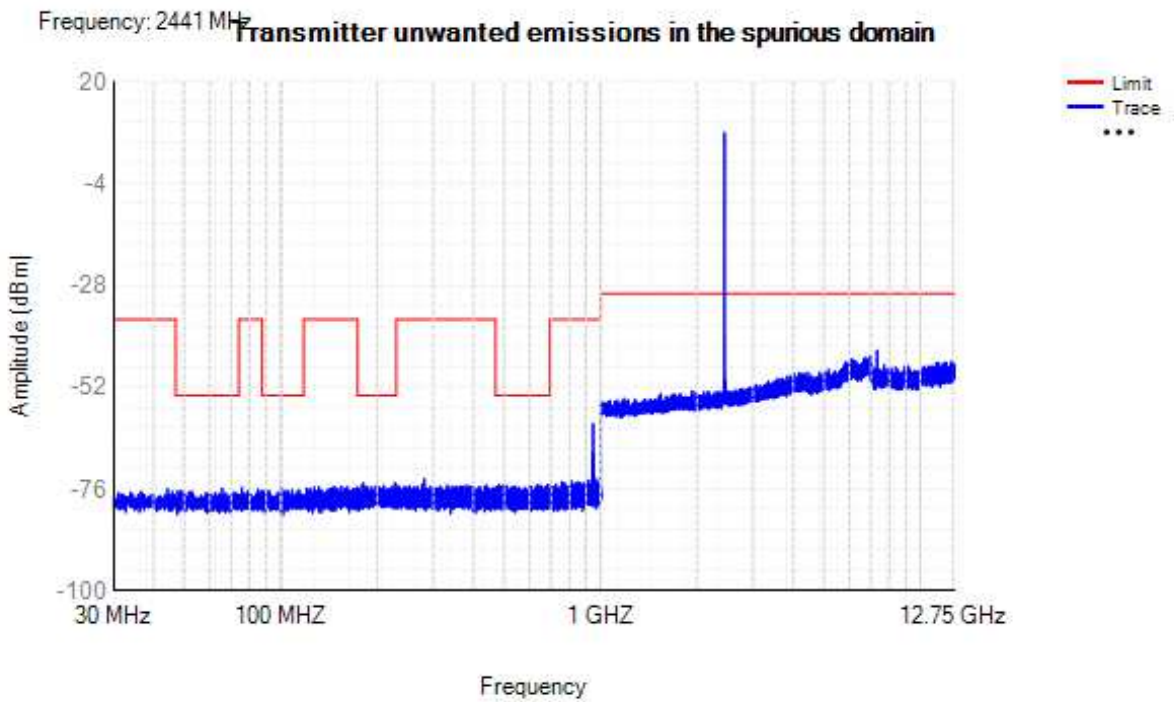

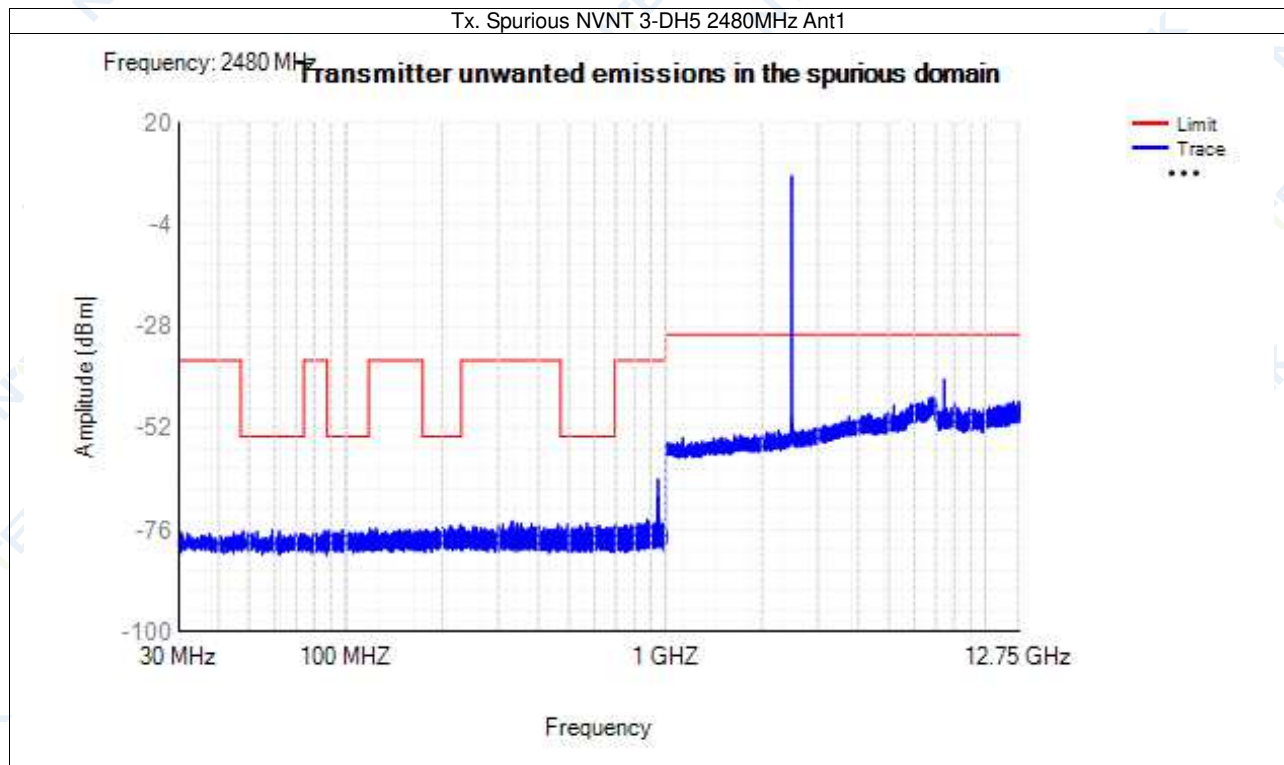

### 11.9 Receiver spurious emissions

Condition	Mode	Frequency (MHz)	Antenna	Range (MHz)	Spur Freq (MHz)	Peak (dBm)	RMS (dBm)	Limit (dBm)	Verdict
NVNT	1-DH5	2402	Ant1	30 -1000	948.25	-66.09	NA	-57	Pass
NVNT	1-DH5	2402	Ant1	1000 -12750	6963	-55.53	NA	-47	Pass
NVNT	1-DH5	2441	Ant1	30 -1000	948.2	-63.69	NA	-57	Pass
NVNT	1-DH5	2441	Ant1	1000 -12750	6820.5	-54.78	NA	-47	Pass
NVNT	1-DH5	2480	Ant1	30 -1000	948.25	-70.87	NA	-57	Pass
NVNT	1-DH5	2480	Ant1	1000 -12750	2477	-53.67	NA	-47	Pass
NVNT	2-DH5	2402	Ant1	30 -1000	945.8	-68.20	NA	-57	Pass
NVNT	2-DH5	2402	Ant1	1000 -12750	6932	-55.12	NA	-47	Pass
NVNT	2-DH5	2441	Ant1	30 -1000	948.25	-67.61	NA	-57	Pass
NVNT	2-DH5	2441	Ant1	1000 -12750	6941	-55.11	NA	-47	Pass
NVNT	2-DH5	2480	Ant1	30 -1000	948.25	-63.97	NA	-57	Pass
NVNT	2-DH5	2480	Ant1	1000 -12750	6934	-54.61	NA	-47	Pass
NVNT	3-DH5	2402	Ant1	30 -1000	948.2	-63.69	NA	-57	Pass
NVNT	3-DH5	2402	Ant1	1000 -12750	6994.5	-55.61	NA	-47	Pass
NVNT	3-DH5	2441	Ant1	30 -1000	948.3	-68.06	NA	-57	Pass
NVNT	3-DH5	2441	Ant1	1000 -12750	6848.5	-55.51	NA	-47	Pass
NVNT	3-DH5	2480	Ant1	30 -1000	948.25	-67.07	NA	-57	Pass
NVNT	3-DH5	2480	Ant1	1000 -12750	6814	-55.15	NA	-47	Pass



Test Graphs  
Rx. Spurious NVNT 1-DH5 2402MHz Ant1

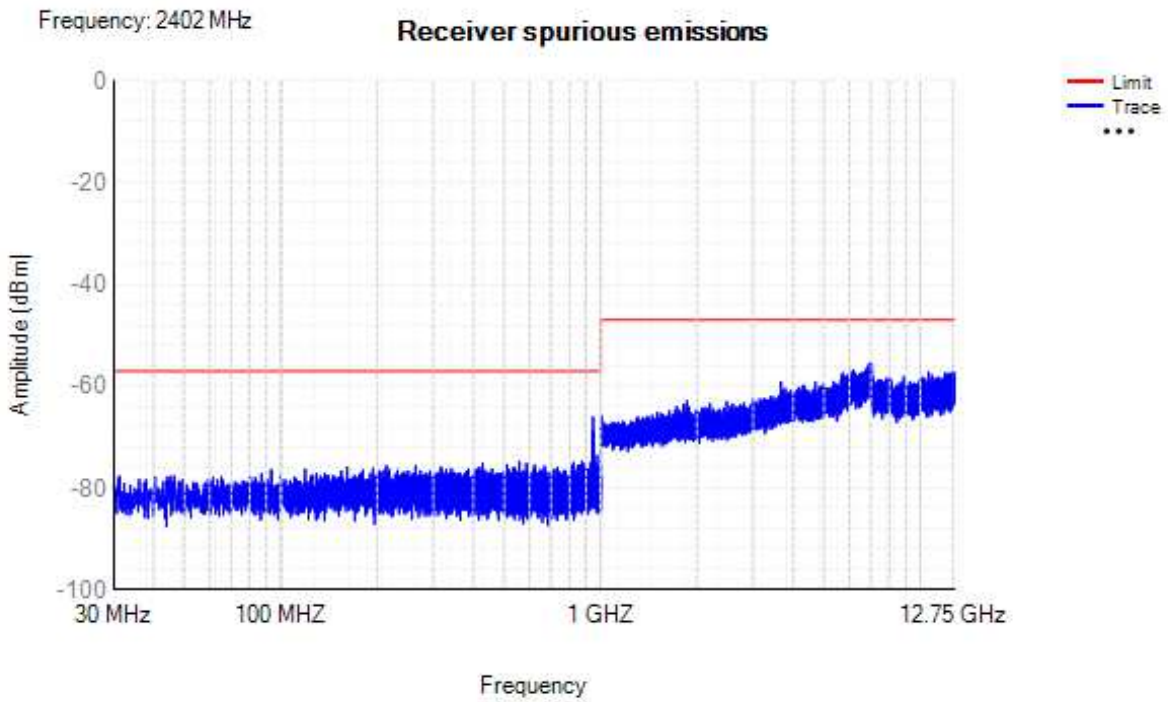

Rx. Spurious NVNT 1-DH5 2441MHz Ant1

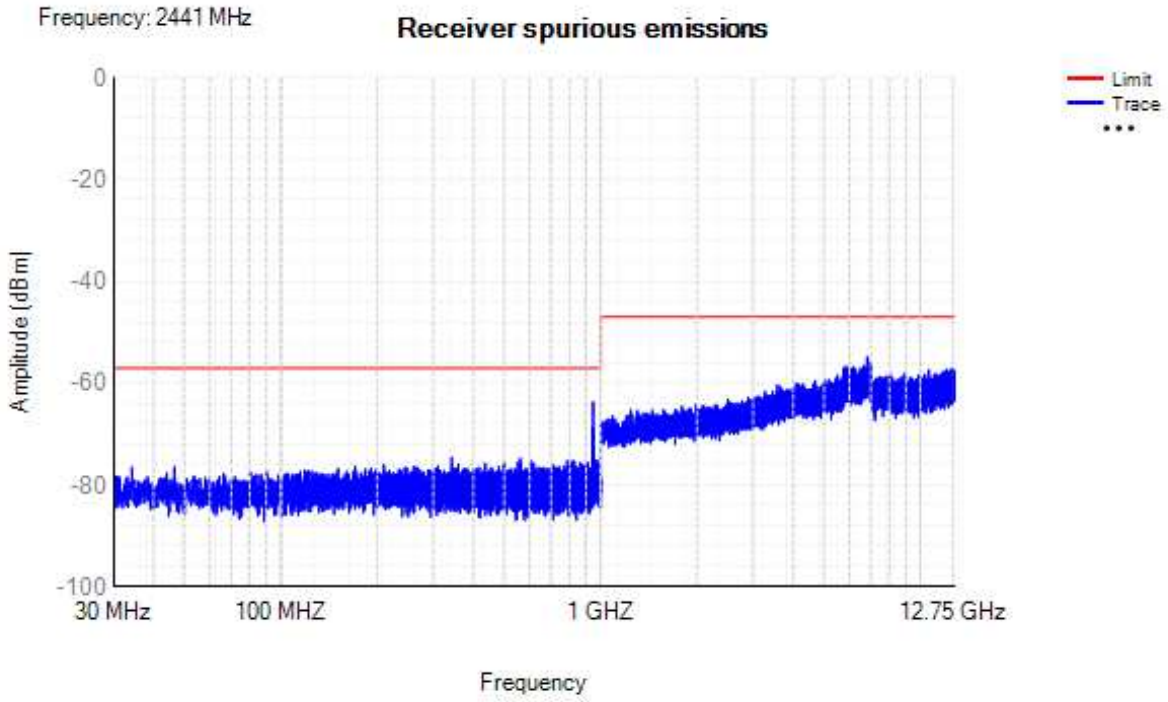

Rx. Spurious NVNT 1-DH5 2480MHz Ant1

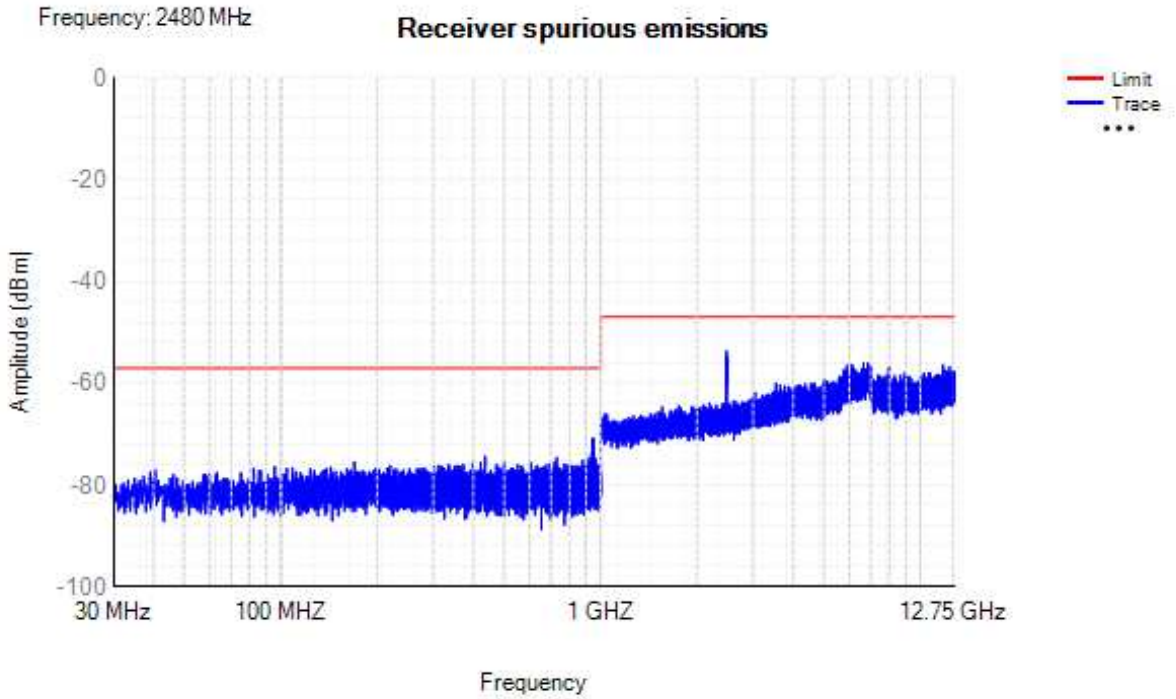

Rx. Spurious NVNT 2-DH5 2402MHz Ant1

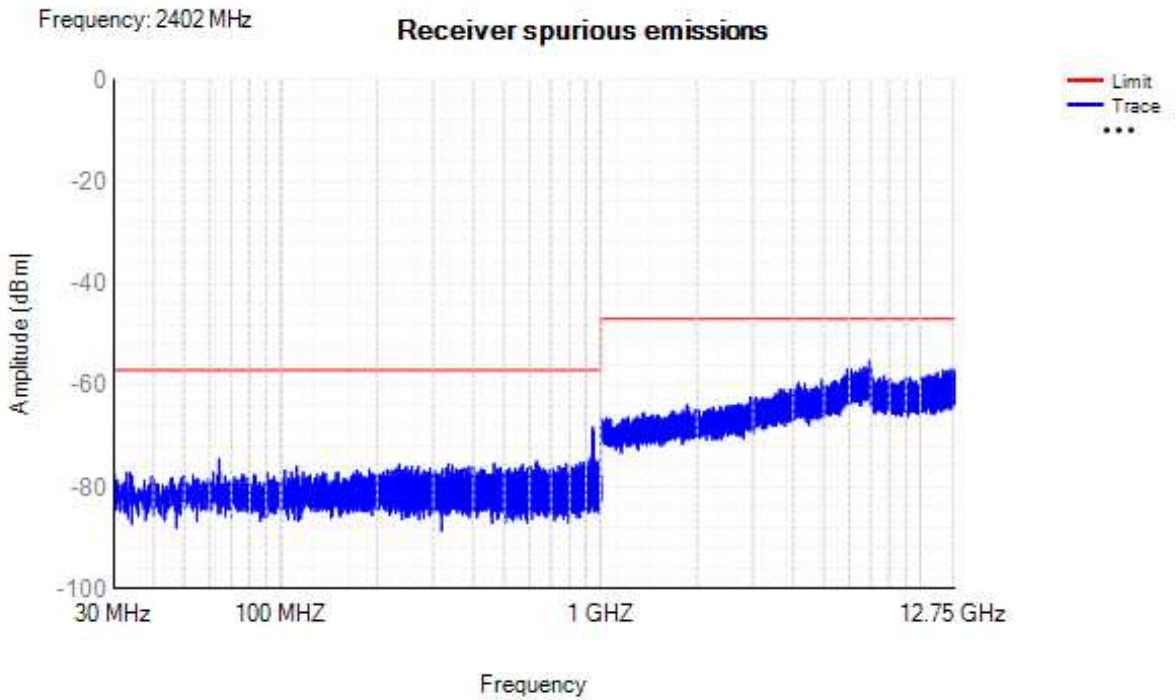



Rx. Spurious NVNT 2-DH5 2441MHz Ant1

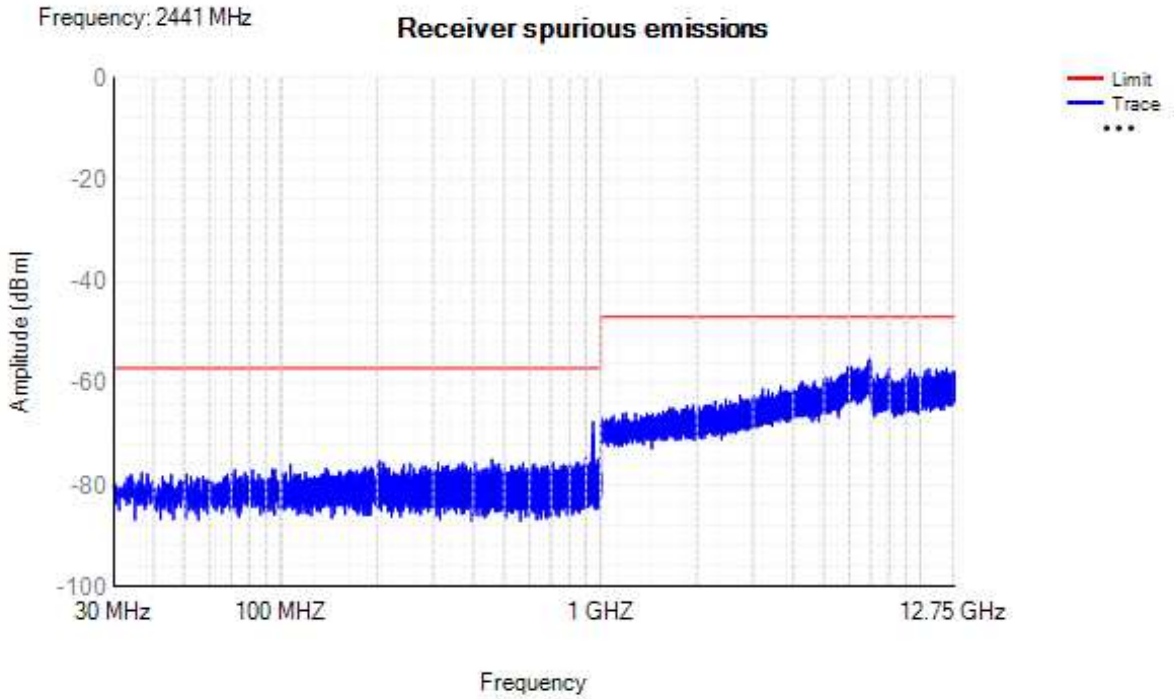

Rx. Spurious NVNT 2-DH5 2480MHz Ant1

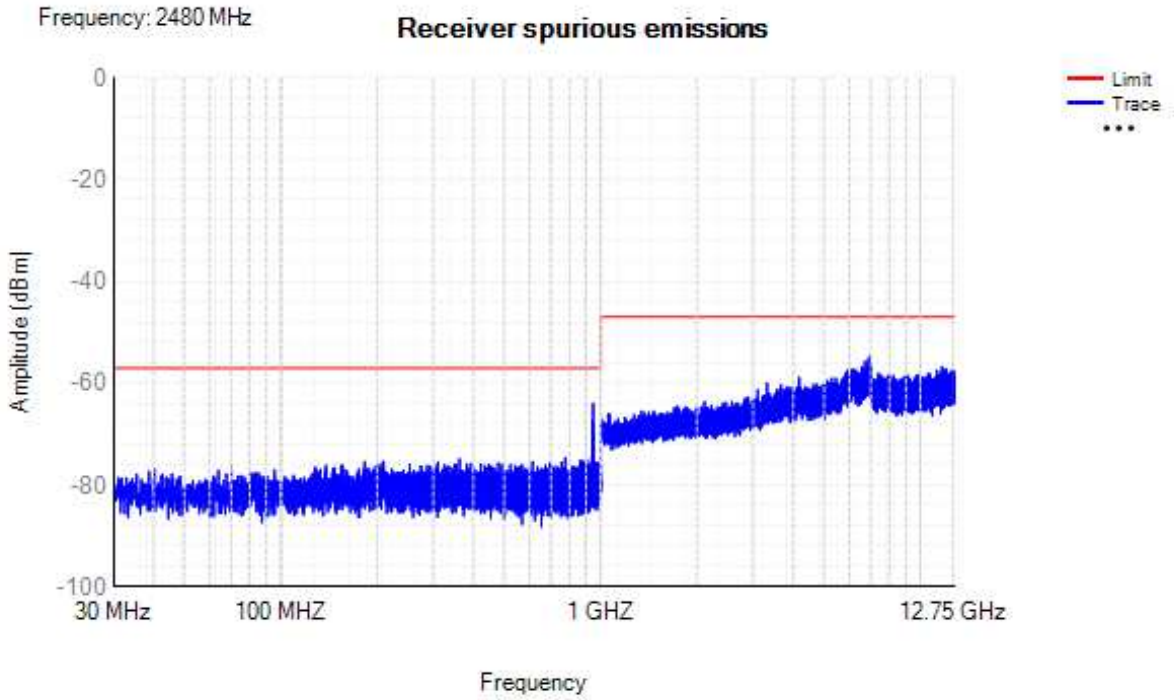

Rx. Spurious NVNT 3-DH5 2402MHz Ant1

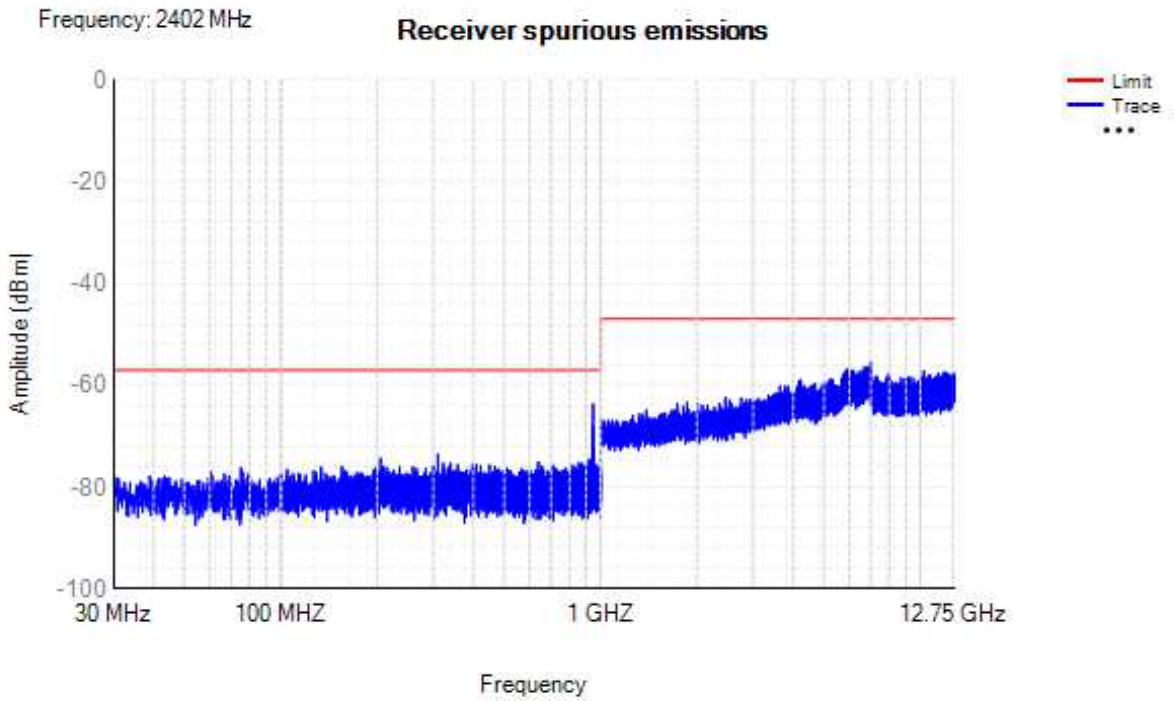

Rx. Spurious NVNT 3-DH5 2441MHz Ant1

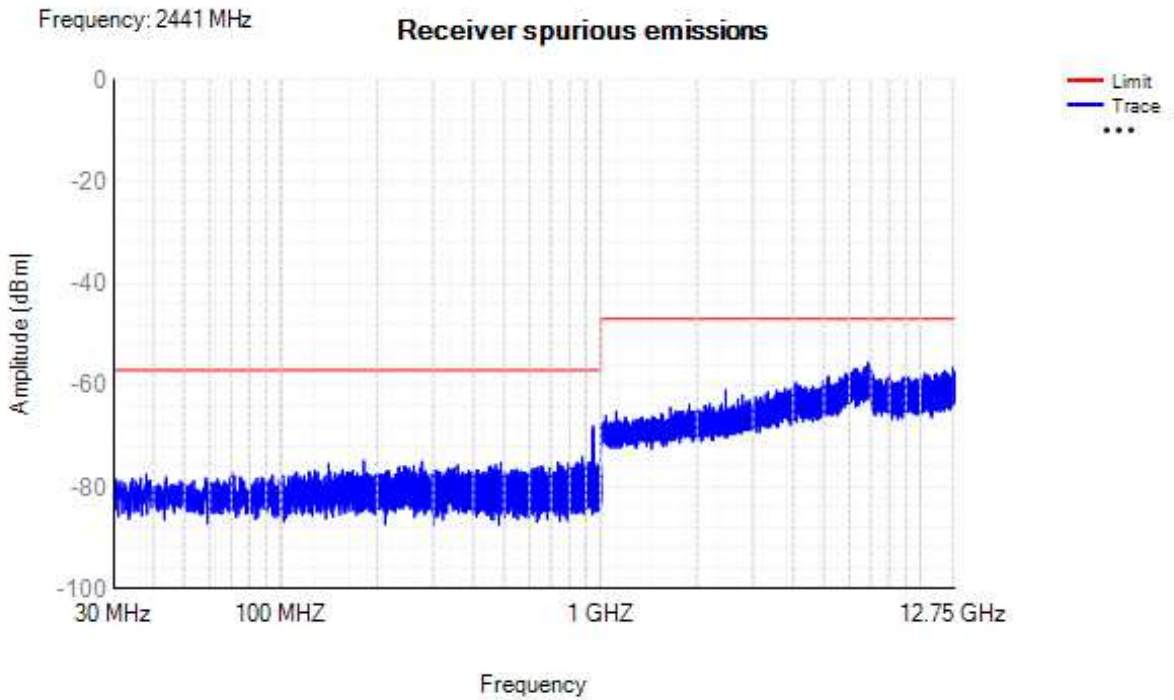

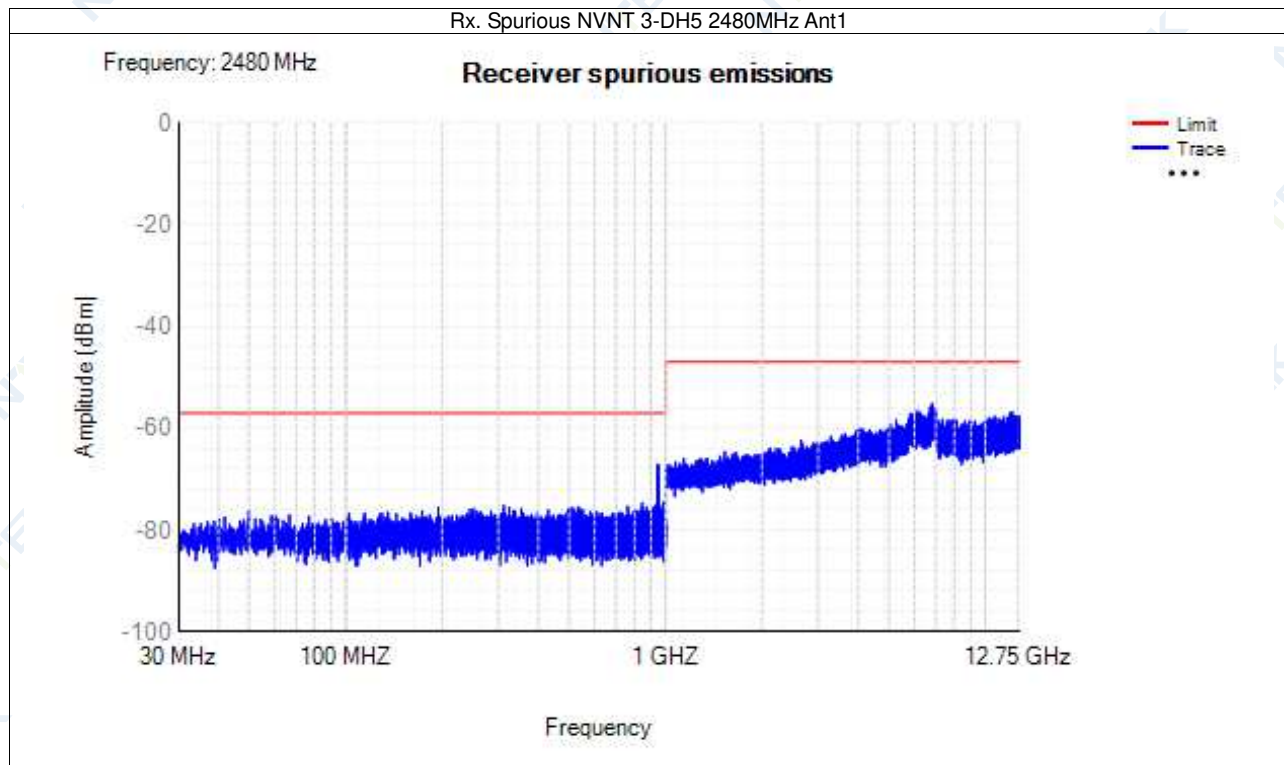

**11.10 Hopping Sequence**

Condition	Mode	Antenna	Hopping Number	Limit	Band Allocation (%)	Limit Band Allocation (%)	Verdict
NVNT	1-DH5	Ant1	79	15	82	70	Pass
NVNT	2-DH5	Ant1	79	15	96.2	70	Pass
NVNT	3-DH5	Ant1	79	15	96	70	Pass

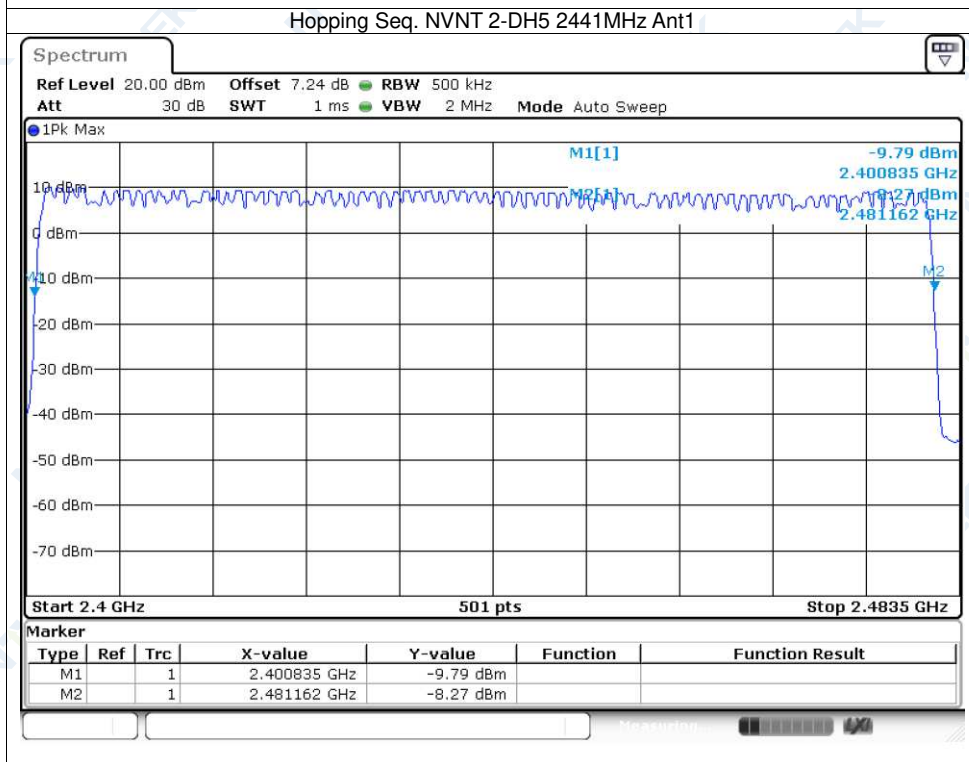
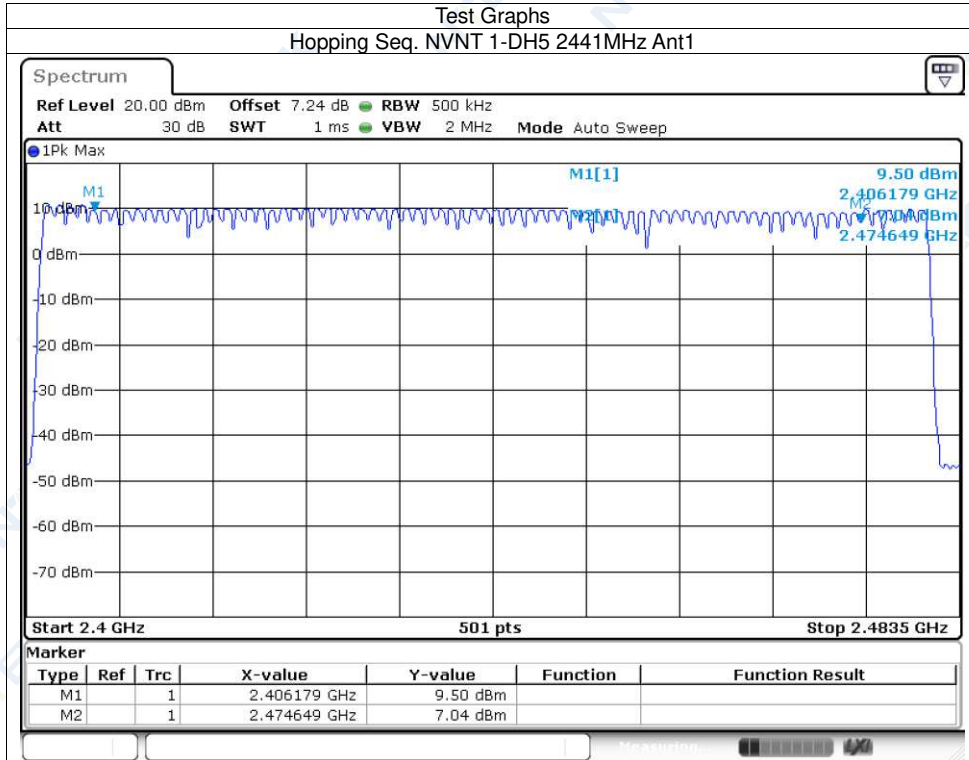

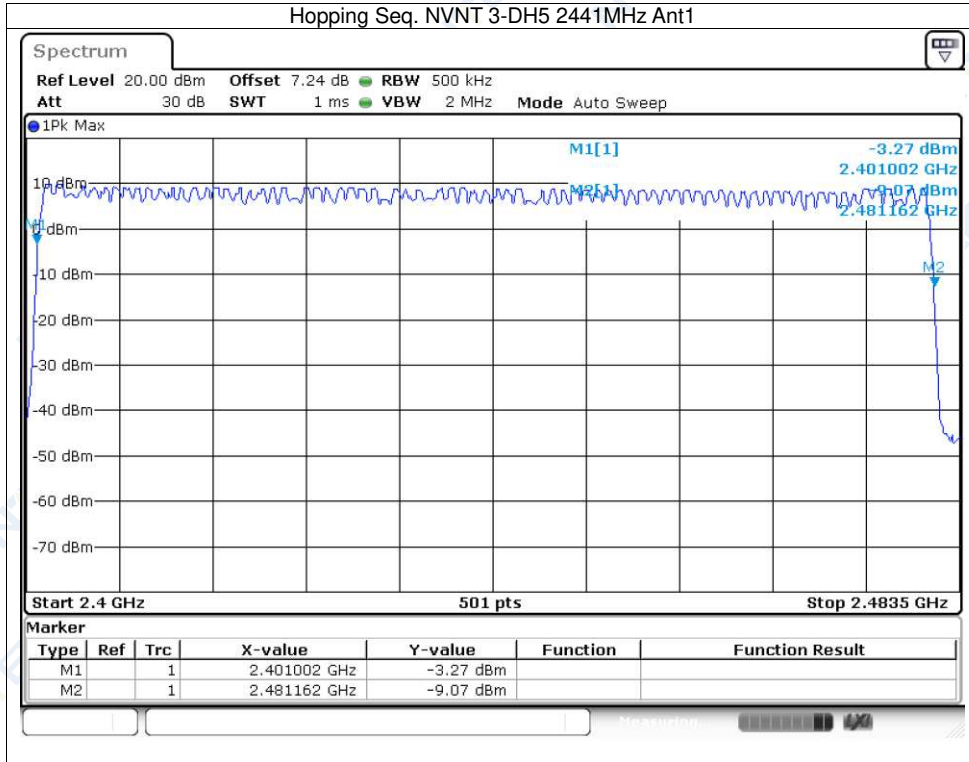



**12. EUT TEST PHOTO**

**SPURIOUS EMISSIONS MEASUREMENT PHOTOS**

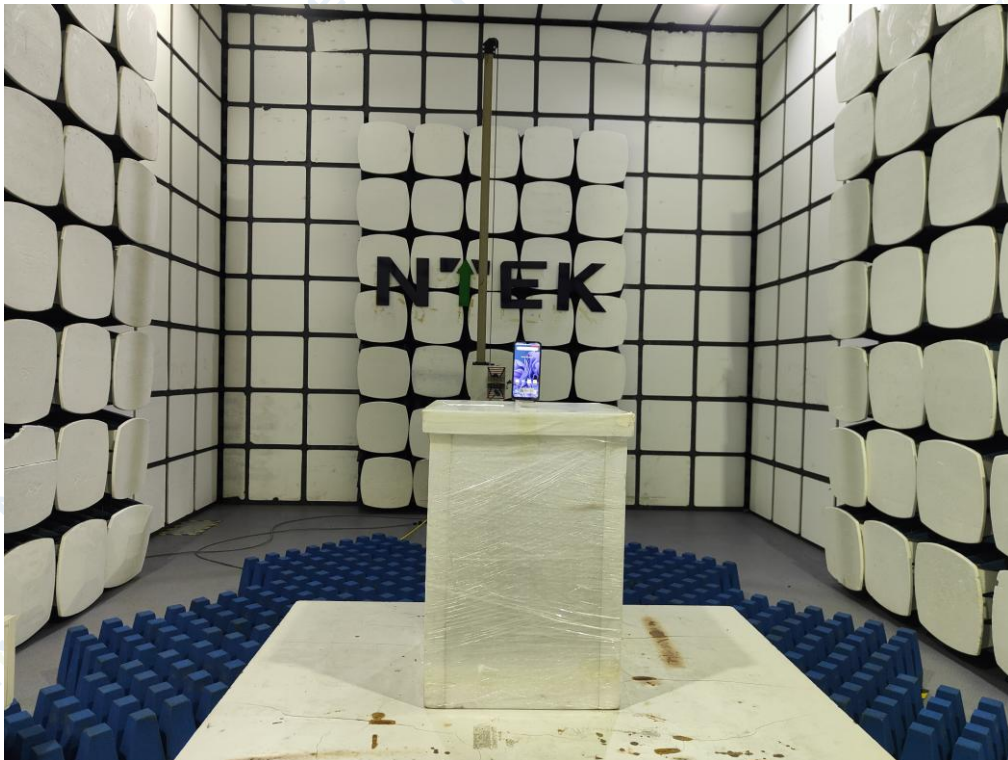

END OF REPORT