



# RADIO TEST REPORT

## ETSI EN 303 413 V1.1.1 (2017-06)

**Product :** Mobile Phone

**Trade Mark :** Blackview

**Model Name :** BV6600

**Family Model :** N/A

**Report No. :** STR201229002008E

### Prepared for

DOKE COMMUNICATION (HK) LIMITED  
RM 1902 EASEY COMM BLDG 253-261 HENNESSY ROAD WANCHAI  
HK CHINA

### Prepared by

Shenzhen NTEK Testing Technology Co., Ltd.

1/F, Building E, Fenda Science Park, Sanwei Community, Xixiang Street  
Bao'an District, Shenzhen 518126 P.R. China

Tel. 400-800-6106, 0755-3699 5508

Website: <http://www.ntek.org.cn>

**TEST RESULT CERTIFICATION**

**Applicant's name** ..... : DOKE COMMUNICATION (HK) LIMITED  
Address..... : RM 1902 EASEY COMM BLDG 253-261 HENNESSY ROAD  
WANCHAI HK CHINA  
**Manufacturer's Name** ..... : Shenzhen DOKE Electronic Co.,Ltd  
Address..... : Room 801, Building 3, 7th Industrial Zone, Yulv Community,  
Yutang Street, Guangming District, Shenzhen,China

**Product description**

Product name..... : Mobile Phone  
Trademark ..... : Blackview  
Model and/or type reference : BV6600  
Family Model ..... : N/A

**Standards** ..... : ETSI EN 303 413 V1.1.1 (2017-06)

This device described above has been tested by Shenzhen NTEK, and the test results show that the equipment under test (EUT) is in compliance with the article 3.2 of Directive 2014/53/EU requirements. And it is applicable only to the tested sample identified in the report.

This report shall not be reproduced except in full, without the written approval of Shenzhen NTEK, this document may be altered or revised by Shenzhen NTEK, personnel only, and shall be noted in the revision of the document.

**Date of Test** .....

Date (s) of performance of tests ..... : 29 Dec. 2020 ~ 19 Jan. 2021

Date of Issue..... : 19 Jan. 2021

Test Result..... : **Pass**

Testing Engineer :

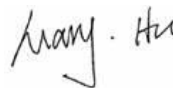

(Mary Hu)

Technical Manager :

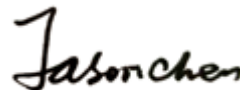

(Jason Chen)

Authorized Signatory :



(Alex Li)

| <b>Table of Contents</b>                                    | <b>Page</b> |
|---|-------------|
| <b>1 . SUMMARY OF TEST RESULTS</b>                          | <b>4</b>    |
| 1.1 TEST FACILITY   | 5           |
| 1.2 MEASUREMENT UNCERTAINTY                                 | 5           |
| <b>2 . GENERAL INFORMATION</b>                              | <b>6</b>    |
| 2.1 GENERAL DESCRIPTION OF EUT                              | 6           |
| 2.2 DESCRIPTION OF TEST CONDITIONS                          | 7           |
| 2.3 BLOCK DIGRAM SHOWING THE CONFIGURATION OF SYSTEM TESTED | 8           |
| 2.4 DESCRIPTION OF SUPPORT UNITS                            | 9           |
| 2.5 EQUIPMENTS LIST FOR ALL TEST ITEMS                      | 10          |
| <b>3 . GUE ADJACENT FREQUENCY BAND SELECTIVITY</b>          | <b>11</b>   |
| 3.1 APPLIED PROCEDURES / LIMIT                              | 11          |
| 3.2 TEST FREQUENCY & SIGNAL                                 | 11          |
| 3.3 TEST PROCEDURE  | 12          |
| 3.4 TEST SETUP  | 12          |
| 3.5 TEST RESULTS  | 13          |
| <b>4 . SPURIOUS EMISSIONS</b>                               | <b>14</b>   |
| 4.1 APPLIED PROCEDURES / LIMIT                              | 14          |
| 4.2 TEST PROCEDURES   | 14          |
| 4.3 TEST SETUP  | 15          |
| 4.4 EUT OPERATION DURING TEST                               | 15          |
| 4.5 TEST RESULTS (30MHZ ~ 1000MHZ)                          | 16          |
| 4.6 TEST RESULTS (1GHZ ~ 8.3GHZ)                            | 17          |
| <b>5 . EUT TEST PHOTO</b>                                   | <b>18</b>   |
| <b>APPENDIX-PHOTOGRAPHS OF EUT CONSTRUCTIONAL DETAILS</b>   |             |

## 1. SUMMARY OF TEST RESULTS

Test procedures according to the technical standards:  
ETSI EN 303 413 V1.1.1 (2017-06)

| Clause              | Description of Test Item                            | Remarks   | Results |
|---------------------|---|-----------|---------|
| Receiver Parameters |   |           |         |
| 4.2.1               | GUE adjacent frequency band selectivity performance | Conducted | Pass    |
| 4.2.2               | Spurious emissions                                  | Radiated  | Pass    |

### 1.1 TEST FACILITY

Shenzhen NTEK Testing Technology Co., Ltd.

Add. : 1/F, Building E, Fenda Science Park, Sanwei Community, Xixiang Street, Bao'an District, Shenzhen 518126 P.R. China

FCC Registered No.: 463705 IC Registered No.:9270A-1

CNAS Registration No.:L5516

### 1.2 MEASUREMENT UNCERTAINTY

The reported uncertainty of measurement  $y \pm U$ , where expanded uncertainty  $U$  is based on a standard uncertainty multiplied by a coverage factor of  $k=2$ , providing a level of confidence of approximately 95%.

| No. | Item                         | Uncertainty             |
|-----|------------------------------|-------------------------|
| 1   | Conducted Emission Test      | $\pm 1.38\text{dB}$     |
| 2   | RF power,conducted           | $\pm 0.16\text{dB}$     |
| 3   | Spurious emissions,conducted | $\pm 0.21\text{dB}$     |
| 4   | All emissions,radiated(<1G)  | $\pm 4.68\text{dB}$     |
| 5   | All emissions,radiated(>1G)  | $\pm 4.89\text{dB}$     |
| 6   | Temperature                  | $\pm 0.5^\circ\text{C}$ |
| 7   | Humidity                     | $\pm 2\%$               |

## 2. GENERAL INFORMATION

### 2.1 GENERAL DESCRIPTION OF EUT

|                     |   |                 |
|---------------------|---|-----------------|
| Equipment           | Mobile Phone  |                 |
| Trade Mark          | Blackview   |                 |
| Model Name          | BV6600  |                 |
| Family Model        | N/A   |                 |
| Model Difference    | N/A   |                 |
| Product Description | Operation Frequency:  | 1.57542GHz      |
|                     | Modulation Type:  | BPSK modulation |
|                     | Antenna Designation:  | FPC Antenna     |
|                     | Antenna Gain(Peak):   | 1.0 dBi         |
|                     | The product only receives.  |                 |
| Channel List        | Refer to below  |                 |
| Adapter             | Model No.:203008611AH<br>Input: 100-240V~50/60Hz 0.6A<br>Output: 5V---3000mA<br>9V---2000mA<br>12V---1500mA 18.0W |                 |
| Battery             | DC 3.85V, 8580mAh, 33.03Wh  |                 |
| Rating              | DC 3.85V from battery or DC 5V from Adapter   |                 |
| Hardware Version    | ZN128 MBB3 BOM10  |                 |
| Software Version    | BV6600_EEA_ZN128F_V1.0  |                 |

Note:

- For a more detailed features description, please refer to the manufacturer's specifications or the User's Manual.

Table for Filed Antenna

| Brand | Model Name | Antenna Type | Connector | Gain (dBi) | NOTE    |
|-------|------------|--------------|-----------|------------|---------|
| N/A   | N/A        | FPC Antenna  | N/A       | 0.8dBi     | Antenna |

**2.2 DESCRIPTION OF TEST CONDITIONS**

| Pretest Mode | Description |
|--------------|-------------|
| Mode 1       | RX(CH01)    |
|              |             |
|              |             |

| <b>For Conducted Test</b> |             |
|---------------------------|-------------|
| Final Test Mode           | Description |
| Mode 1                    | RX(CH01)    |
|                           |             |

| <b>For Radiated Test</b> |             |
|--------------------------|-------------|
| Final Test Mode          | Description |
| Mode 1                   | RX(CH01)    |
|                          |             |

**2.3 BLOCK DIGRAM SHOWING THE CONFIGURATION OF SYSTEM TESTED**

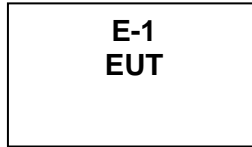



## 2.4 DESCRIPTION OF SUPPORT UNITS

The EUT has been tested as an independent unit together with other necessary accessories or support units. The following support units or accessories were used to form a representative test configuration during the tests.

| Item | Equipment    | Brand     | Model/Type No. | Series No. | Note |
|------|--------------|-----------|----------------|------------|------|
| E-1  | Mobile Phone | Blackview | BV6600         | N/A        | EUT  |
|      |              |           |                |            |      |
|      |              |           |                |            |      |
|      |              |           |                |            |      |
|      |              |           |                |            |      |

| Item | Shielded Type | Ferrite Core | Length | Note |
|------|---------------|--------------|--------|------|
|      |               |              |        |      |
|      |               |              |        |      |
|      |               |              |        |      |
|      |               |              |        |      |
|      |               |              |        |      |

Note:

- (1) The support equipment was authorized by Declaration of Confirmation.
- (2) For detachable type I/O cable should be specified the length in cm in 『Length』 column.
- (3) "YES" means "shielded" or "with ferrite core"; "NO" means "unshielded" or "without ferrite core"

**2.5 EQUIPMENTS LIST FOR ALL TEST ITEMS**

| Item | Kind of Equipment                    | Manufacturer  | Type No.    | Serial No.    | Last calibration | Calibrated until | Calibration period |
|------|--------------------------------------|---------------|-------------|---------------|------------------|------------------|--------------------|
| 1    | Spectrum Analyzer                    | Agilent       | E4407B      | 160400005     | 2020.05.11       | 2021.05.10       | 1 year             |
| 2    | Test Receiver                        | R&S           | ESPI7       | 101318        | 2020.05.11       | 2021.05.10       | 1 year             |
| 3    | Bilog Antenna                        | TESEQ         | CBL6111D    | 31216         | 2020.04.11       | 2021.04.10       | 1 year             |
| 4    | 50Ω Coaxial Switch                   | Anritsu       | MP59B       | 6200983705    | 2020.05.11       | 2023.05.10       | 3 year             |
| 5    | Spectrum Analyzer                    | ADVANTES T    | R3132       | 150900201     | 2020.05.11       | 2021.05.10       | 1 year             |
| 6    | Horn Antenna                         | EM            | EM-AH-20180 | 2011071402    | 2020.04.11       | 2021.04.10       | 1 year             |
| 7    | Horn Ant                             | Schwarzbeck   | BBHA 9170   | 9170-181      | 2020.05.11       | 2021.05.10       | 1 year             |
| 8    | Pre-Amplifier                        | EMC           | EMC051835SE | 980246        | 2020.07.13       | 2021.07.12       | 1 year             |
| 9    | Loop Antenna                         | ARA           | PLA-2030/B  | 1029          | 2020.05.11       | 2021.05.10       | 1 year             |
| 10   | USB RF Power Sensor                  | DARE          | RPR3006W    | 15I00041SN084 | 2020.07.13       | 2021.07.12       | 1 year             |
| 11   | Signal Generator                     | R&S           | SMT 06      | 832080/007    | 2020.05.11       | 2021.05.10       | 1 year             |
| 12   | Temperature & Humidity Chamber       | GIANT FORCE   | GTH-056P    | GF-94454-1    | 2020.05.11       | 2021.05.10       | 1 year             |
| 13   | Power Sensor                         | R&S           | URV5-Z4     | 0395.1619.05  | 2020.05.11       | 2021.05.10       | 1 year             |
| 14   | MXA Signal Analyzer                  | Agilent       | N9020A      | MY49100060    | 2020.07.13       | 2021.07.12       | 1 year             |
| 15   | LTE Wireless Communications Test Set | R&S           | CMW500      | 1100.008.02   | 2020.05.11       | 2021.05.10       | 1 year             |
| 16   | MXG Vector Signal Generator          | Agilent       | N5182A      | MY47070317    | 2020.05.11       | 2021.05.10       | 1 year             |
| 17   | Power Splitter                       | Mini-Circuits | ZN2PD-63-S  | SF025101618   | 2020.05.11       | 2021.05.10       | 1 year             |

### 3. GUE ADJACENT FREQUENCY BAND SELECTIVITY

#### 3.1 APPLIED PROCEDURES / LIMIT

The limits please refer to ETSI EN 303 413 V1.1.1 (2017-06) V4.2.1.2.

| Clause | Test Item                               | Limit                            |
|--------|---|----------------------------------|
| 4.2.1  | GUE adjacent frequency band selectivity | $\Delta C/N_0 \leq 1 \text{ dB}$ |

#### 3.2 TEST FREQUENCY & SIGNAL

According to ETSI EN 303 413 V1.1.1 the test wanted signal please see the below Table B-1, Table B-2, Table B-3, And the unwanted signal please see the Table 4-1, Table 4-2, Table 4-4.

**Table 4-1: GNSS, GNSS signals and RNSS frequency bands**

| GNSS    | GNSS Signal Designations | RNSS Frequency Band (MHz) |
|---------|--------------------------|---------------------------|
| BDS     | B1I                      | 1 559 to 1 610            |
| Galileo | E1                       | 1 559 to 1 610            |
|         | E5a                      | 1 164 to 1 215            |
|         | E5b                      | 1 164 to 1 215            |
|         | E6                       | 1 215 to 1 300            |
| GLONASS | G1                       | 1 559 to 1 610            |
|         | G2                       | 1 215 to 1 300            |
| GPS     | L1                       | 1 559 to 1 610            |
|         | L2                       | 1 215 to 1 300            |
|         | L5                       | 1 164 to 1 215            |
| SBAS    | L1                       | 1 559 to 1 610            |
|         | L5                       | 1 164 to 1 215            |

**Table 4-2: Frequency bands, adjacent frequency signal test point centre frequencies and power levels for the 1 559 MHz to 1 610 MHz RNSS band**

| Frequency band (MHz) | Test point centre frequency (MHz) | Adjacent frequency signal power level (dBm) | Comments                  |
|----------------------|-----------------------------------|---|---------------------------|
| 1 518 to 1 525       | 1 524                             | -65   | MSS (space-to-Earth) band |
| 1 525 to 1 549       | 1 548                             | -95   | MSS (space-to-Earth) band |
| 1 549 to 1 559       | 1 554                             | -105  | MSS (space-to-Earth) band |
| 1 559 to 1 610       | GUE RNSS band under test          |   |                           |
| 1 610 to 1 626       | 1 615                             | -105  | MSS (Earth-to-space) band |
| 1 626 to 1 640       | 1 627                             | -85   | MSS (Earth-to-space) band |

**Table 4-4: Adjacent frequency signal**

| Parameter   | Value                       | Comments                   |
|-------------|-----------------------------|----------------------------|
| Frequency   | See table 4-2 and table 4-3 |                            |
| Power level | See table 4-2 and table 4-3 |                            |
| Bandwidth   | 1 MHz                       | See clause B.1 for details |
| Format      | AWGN                        |                            |

**Table B-1: GNSS, GNSS signals and relative signal levels**

|  | Galileo   |       | GPS/Modernized GPS |         | GLONASS |       | SBAS |    | BDS (see note 2) |     |       |
|--|---|-------|--------------------|---------|---------|-------|------|----|------------------|-----|-------|
|  | Signal levels relative to reference power levels (see note 1) | E1    | 0 dB               | L1 C/A  | 0 dB    | G1    | 0 dB | L1 | 0 dB             | B1I | D1    |
|  | E6  | +2 dB | L1C                | +1,5 dB | G2      | -6 dB |      |    |                  | D2  | +5 dB |
|  | E5  | +2 dB | L2C                | -1,5 dB |         |       |      |    |                  |     |       |
|  |   |       | L5                 | +3,6 dB |         |       |      |    |                  |     |       |

NOTE 1: The signal levels represent the total signal power of the satellite per channel, not for example pilot and data channels separately.

NOTE 2: For BDS, D1 represents MEO/IGSO satellites B1I signal type and D2 represents GEO satellites B1I signal type.

**Table B-2: Relative signal levels for each GNSS supported**

| GNSS    | Relative signal level for all satellites (see note) |
|---------|---|
| GPS     | 0 dB  |
| Galileo | +1,5 dB   |
| GLONASS | -2,5 dB   |
| SBAS    | -2,5 dB   |
| BDS     | -4,5 dB   |

NOTE: GPS is used as the reference GNSS. If GPS is not supported then values shall be adjusted and referenced to another supported GNSS.

**Table B-3: (Maximum) signal levels for each GNSS supported**

| GNSS    | Parameters             | Value      |
|---------|------------------------|------------|
| GPS     | (Maximum) signal level | -128,5 dBm |
| Galileo | (Maximum) signal level | -127 dBm   |
| GLONASS | (Maximum) signal level | -131 dBm   |
| SBAS    | (Maximum) signal level | -131 dBm   |
| BDS     | (Maximum) signal level | -133 dBm   |

**3.3 TEST PROCEDURE**

According to ETSI EN 303 413 V1.1.1 Clause 5.4& Annex B.2.

| Measurement   |   |
|---|---|
| <input checked="" type="checkbox"/> Conducted measurement | <input type="checkbox"/> Radiated measurement |

- 1) Configure the GNSS signal generator to simulate those GNSS and GNSS signals from table 4-1 declared as supported by the GUE, with power levels and other details as specified in clause B.2.
- 2) With the adjacent frequency signal switched off, the EUT shall be given sufficient time to acquire all simulated satellites from the declared GNSS system(s).
- 3) Record the baseline C/N<sub>0</sub> value(s) reported by the EUT. Sufficient filtering shall be used to obtain a stable value. C/N<sub>0</sub> may be averaged across all the satellites in view for each GNSS constellation. However, C/N<sub>0</sub> shall not be averaged across satellite signals in different GNSS constellations. For a multi-GNSS EUT, there shall be a separate C/N<sub>0</sub> value recorded for each GNSS constellation and each GNSS signal supported.
- 4) The adjacent frequency signal generator shall be configured to generate the signal defined in table 4-4, at the first test point centre frequency and signal power level as specified in table 4-2.
- 5) The adjacent frequency signal shall be switched on, and the EUT's C/N<sub>0</sub> value(s) recorded as in step 3) to measure the degradation with respect to the baseline value(s) recorded in step 3).
- 6) Test point Pass/Fail Criteria: If the C/N<sub>0</sub> degradation from step 5) does not exceed the value in equation 4-1, then this test point is set to "pass". If the C/N<sub>0</sub> degradation exceeds the value in equation 4-1, then this test point is set to "fail." For a multi-GNSS and multi-signal EUT, there shall be a separate pass/fail determination for each GNSS and for each GNSS signal supported. If the C/N<sub>0</sub> degradation exceeds the value in equation 4-1 for any supported GNSS or supported GNSS signal, then this test point is set to "fail".
- 7) Step 1) through step 6) shall be repeated for all test point centre frequencies (and associated signal power level) specified in table 4-2.

**3.4 TEST SETUP**

Please see the below figure 5-1:

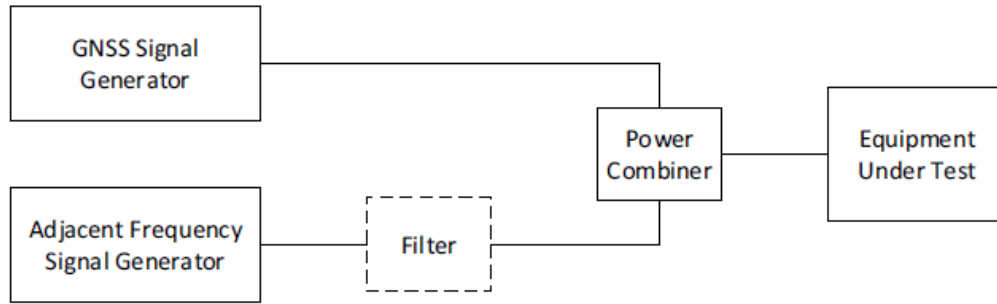

Figure 5-1: Conducted measurement setup for EUT adjacent frequency band selectivity

3.5 TEST RESULTS

|               |              |                     |                   |
|---------------|--------------|---------------------|-------------------|
| EUT :         | Mobile Phone | Model Name :        | BV6600            |
| Temperature : | 26°C         | Relative Humidity : | 60 %              |
| Pressure :    | 1012 hPa     | Test Voltage :      | DC 3.85V (Normal) |
| Test Mode :   | GPS RX       |                     |                   |

| Test point centre frequency | signal power level | C/N <sub>0</sub> value ( adjacent frequency signal switched off) | C/N <sub>0</sub> value ( adjacent frequency signal switched on) | Δ C/N <sub>0</sub> | Limit(Δ C/N <sub>0</sub> ) | Results |
|-----------------------------|--------------------|--|---|--------------------|----------------------------|---------|
| (MHz)                       | ( dBm )            |  |   |                    | (dB)                       | (P/F)   |
| 1575.42                     | -128.5             |  |   |                    |                            |         |
| 1524                        | -65                | 32.91  | 33.42   | 0.51               | ≤ 1 dB                     | PASS    |
| 1548                        | -95                | 32.86  | 33.43   | 0.57               | ≤ 1 dB                     | PASS    |
| 1554                        | -105               | 32.88  | 33.45   | 0.57               | ≤ 1 dB                     | PASS    |
| 1615                        | -105               | 32.93  | 33.42   | 0.49               | ≤ 1 dB                     | PASS    |
| 1627                        | -85                | 32.95  | 33.494  | 0.54               | ≤ 1 dB                     | PASS    |

Note: We test the C/N0 value for each GNSS, but the report just reported the worst Δ C/N<sub>0</sub> values.

## 4. SPURIOUS EMISSIONS

### 4.1 APPLIED PROCEDURES / LIMIT

The limits please refer to ETSI EN 303 413 V1.1.1 (2017-06) clause 4.2.2.2.

**Table 4-5: Spurious emission limits**

| Frequency range  | Maximum power | Bandwidth |
|------------------|---------------|-----------|
| 30 MHz to 1 GHz  | -57 dBm       | 100 kHz   |
| 1 GHz to 8,3 GHz | -47 dBm       | 1 MHz     |

### 4.2 TEST PROCEDURES

According to ETSI EN 303 413 V1.1.1 Clause 5.5.

| Measurement                                    |  |
|--|--|
| <input type="checkbox"/> Conducted measurement | <input checked="" type="checkbox"/> Radiated measurement |

The test site as described in ETSI EN 300 328 [1], annex B and the applicable measurement procedures as described in ETSI EN 300 328 [1], annex C shall be used.

The test procedure is further described in clause 5.5.2.1.

**4.3 TEST SETUP**

(A) Radiated Emission Test Set-Up Frequency Below 1 GHz

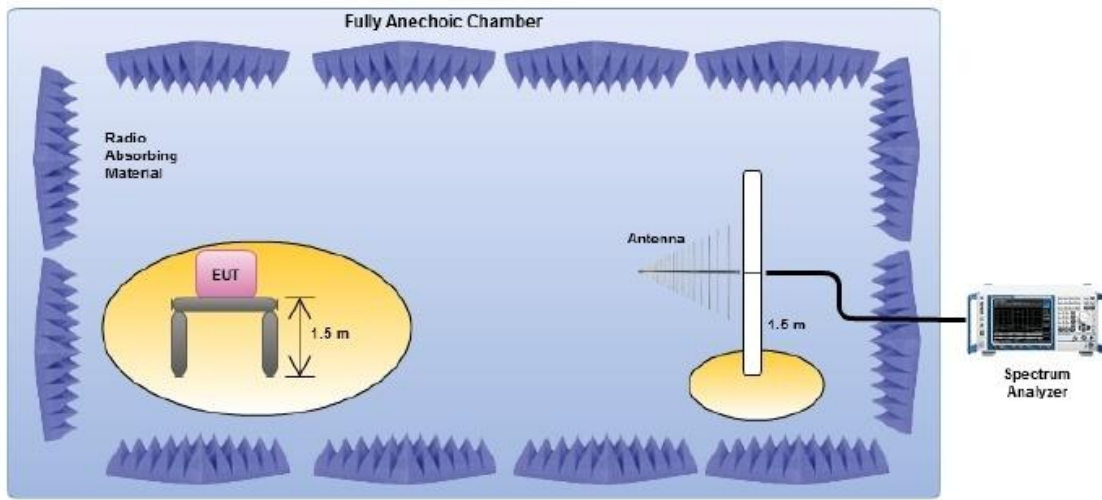

(B) Radiated Emission Test Set-Up Frequency Above 1GHz

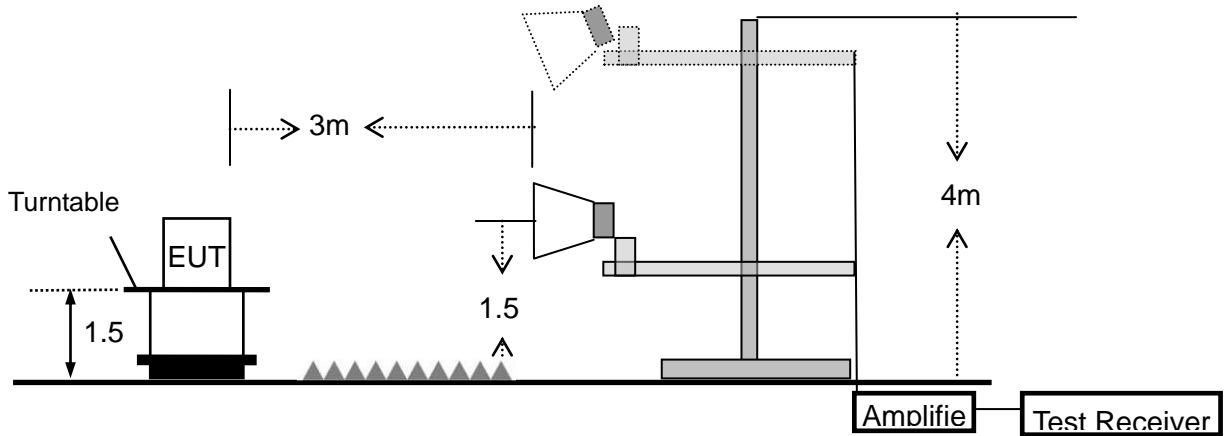

**4.4 EUT OPERATION DURING TEST**

The EUT was programmed to be in receiving mode.

## 4.5 TEST RESULTS (30MHZ ~ 1000MHz)

|               |              |                     |          |
|---------------|--------------|---------------------|----------|
| EUT :         | Mobile Phone | Model Name :        | BV6600   |
| Temperature : | 24 °C        | Relative Humidity : | 54%      |
| Pressure :    | 1010 hPa     | Test Power :        | DC 3.85V |
| Test Mode :   | Mode 1       |                     |          |

| Polar<br>(H/V) | Frequency | Meter<br>Reading | Factor | Emission<br>Level | Limits | Margin | Detector<br>Type |
|----------------|-----------|------------------|--------|-------------------|--------|--------|------------------|
|                | (MHz)     | (dBm)            | (dB)   | (dBm)             | (dBm)  | (dB)   |                  |
| H              | 98.4865   | -80.08           | 10.68  | -69.40            | -57.00 | -12.40 | peak             |
| H              | 104.9033  | -77.49           | 11.09  | -66.40            | -57.00 | -9.40  | peak             |
| H              | 126.3285  | -80.67           | 12.27  | -68.40            | -57.00 | -11.40 | peak             |
| H              | 144.3348  | -83.21           | 12.09  | -71.12            | -57.00 | -14.12 | peak             |
| H              | 387.9920  | -83.14           | 17.24  | -65.90            | -57.00 | -8.90  | peak             |
| H              | 842.1295  | -91.86           | 26.16  | -65.70            | -57.00 | -8.70  | peak             |
| V              | 91.4949   | -75.93           | 10.03  | -65.90            | -57.00 | -8.90  | peak             |
| V              | 95.7622   | -83.09           | 10.19  | -72.90            | -57.00 | -15.90 | peak             |
| V              | 251.1802  | -79.05           | 13.55  | -65.50            | -57.00 | -8.50  | peak             |
| V              | 423.5403  | -86.97           | 18.27  | -68.70            | -57.00 | -11.70 | peak             |
| V              | 454.3100  | -84.00           | 18.80  | -65.20            | -57.00 | -8.20  | peak             |
| V              | 483.9094  | -87.28           | 19.58  | -67.70            | -57.00 | -10.70 | peak             |

**Remark:**

Emission Level= Meter Reading+ Factor, Margin= Emission Level- Limit

Note: Only the worst case recorded in the report.



**4.6 TEST RESULTS (1GHz ~ 8.3GHz)**

|               |              |                     |          |
|---------------|--------------|---------------------|----------|
| EUT :         | Mobile Phone | Model Name :        | BV6600   |
| Temperature : | 24 °C        | Relative Humidity : | 54%      |
| Pressure :    | 1010 hPa     | Test Power :        | DC 3.85V |
| Test Mode :   | Mode 1       |                     |          |

| Polar<br>(H/V) | Frequency | Meter<br>Reading | Factor | Emission<br>Level | Limits | Margin | Remark |
|----------------|-----------|------------------|--------|-------------------|--------|--------|--------|
|                | (MHz)     | (dBm)            | (dB)   | (dBm)             | (dBm)  | (dB)   |        |
| H              | 1558.125  | -61.79           | 2.91   | -58.88            | -47    | -11.88 | peak   |
| H              | 2331.214  | -65.56           | 7.81   | -57.75            | -47    | -10.75 | peak   |
| H              | 2452.971  | -66.3            | 8.37   | -57.93            | -47    | -10.93 | peak   |
| H              | 2703.75   | -67.56           | 9.81   | -57.75            | -47    | -10.75 | peak   |
| H              | 3526.25   | -68.77           | 8.27   | -60.5             | -47    | -13.5  | peak   |
| H              | 4260.625  | -68.46           | 7.79   | -60.67            | -47    | -13.67 | peak   |
| V              | 2159.816  | -65.93           | 8.42   | -57.51            | -47    | -10.51 | peak   |
| V              | 2292.5    | -64.51           | 7.44   | -57.07            | -47    | -10.07 | peak   |
| V              | 2791.875  | -65.3            | 9.14   | -56.16            | -47    | -9.16  | peak   |
| V              | 3203.125  | -68.01           | 8.14   | -59.87            | -47    | -12.87 | peak   |
| V              | 3673.125  | -69.78           | 7.59   | -62.19            | -47    | -15.19 | peak   |
| V              | 4231.25   | -68.35           | 7.96   | -60.39            | -47    | -13.39 | peak   |

1. Emission Level= Meter Reading+ Factor, Margin= Emission Level- Limit.
2. All the modes had been tested, but only the worst data recorded in the report.

Note: Only the worst case recorded in the report.

5. EUT TEST PHOTO

Radiated Measurement Photos

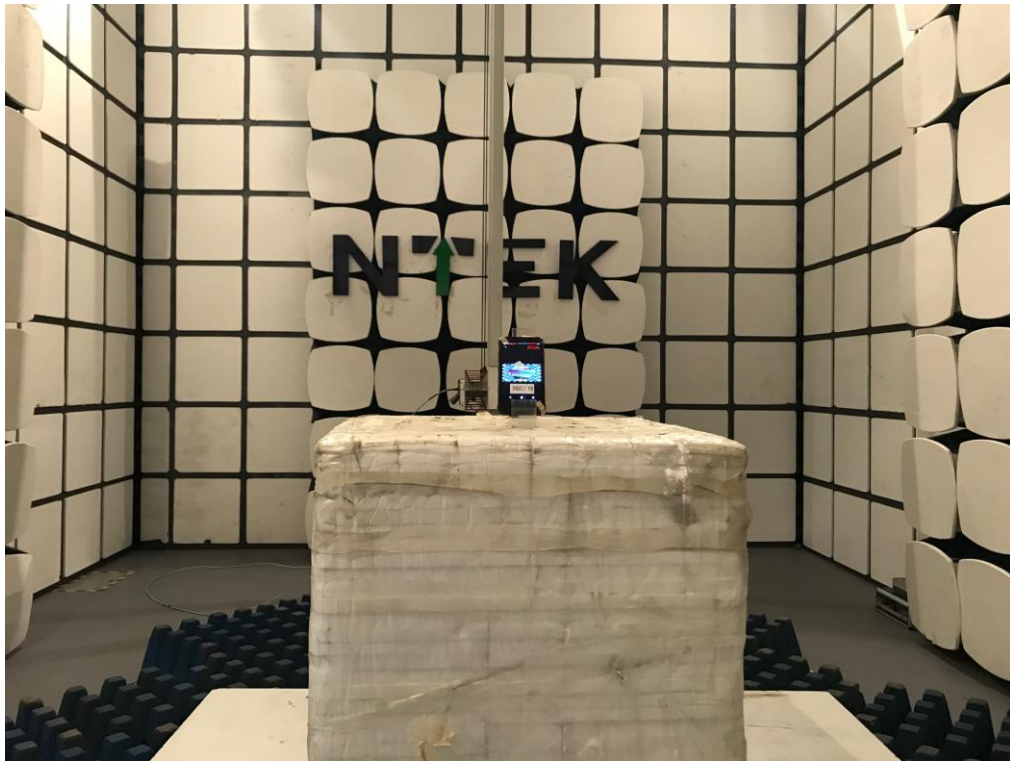
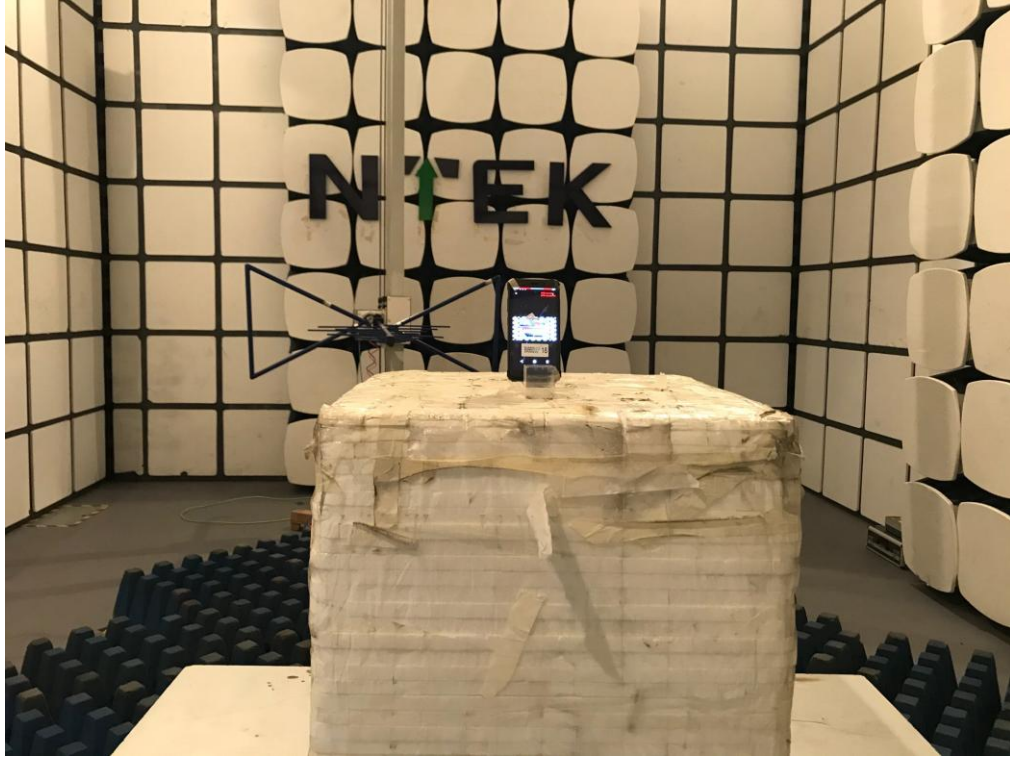

END OF REPORT