

RF TEST REPORT

Applicant : DOKE COMMUNICATION (HK) LIMITED
Address : RM 1902 EASEY COMM BLDG 253-261 HENNESSY ROAD
WANCHAI HK CHINA
Manufacturer : Shenzhen DOKE Electronic Co., Ltd
Address : 801, Building3, 7th Industrial Zone, Yulv Community, Yutang Road,
Guangming District, Shenzhen, China.
Product Name : Tablet
Brand Name : Blackview
Test Model : Active 6
Series Model : N/A
Date of Receipt : 2023.07.13
Date of Test : 2023.07.13~2023.08.07
Issued Date : 2023.08.08
Report Version : V1.0
Test Sample : Engineering Sample No.: AIT23071306-1
Standard(s) : ETSI EN 301 908-1 V15.1.1: 2021-09
ETSI EN 301 908-2 V13.1.1: 2020-06

Lab: Dongguan Yaxu (AiT) Technology Limited
Add: No.22, Jinqianling 3rd Street, Jitigang, Huangjiang, Dongguan,
Guangdong, China
Tel.: +86-769-8202 0499 Fax.: +86-769-8202 0495

This device has been tested and found to comply with the stated standard(s), which is (are) required by the council directive of 2014/53/EU and indicated in the test report and are applicable only to the tested sample identified in the report.

Note: This report shall not be reproduced except in full, without the written approval of Dongguan Yaxu (AiT) Technology Limited, this document may be altered or revised by Dongguan Yaxu (AiT) Technology Limited, personal only, and shall be noted in the revision of the document.
This test report must not be used by the client to claim product endorsement.

Reviewed by: Simba Huang
Simba huang

Approved by: Eder Zhan
Eder Zhan





REPORT REVISE RECORD

Report Version	Revise Time	Issued Date	Valid Version	Notes
V1.0	/	2023.08.02	Valid	Initial Release

TABLE OF CONTENTS

1. PRODUCT INFORMATION	4
1.1. PRODUCT TECHNICAL DESCRIPTION	4
1.2. DESCRIPTION OF TEST MODES AND TEST FREQUENCY	5
1.3. OBJECTIVE	5
1.4. TEST ITEMS AND THE RESULTS	5
1.5. TYPE OF MOBILE STATION AND ADDITIONAL INFORMATION	7
2. TEST ENVIRONMENT	8
2.1 ADDRESS OF THE TEST LABORATORY	8
2.2 ENVIRONMENTAL CONDITIONS	8
2.2 SETUP CONFIGURATION OF EUT	8
2.4 MEASUREMENT UNCERTAINTY	9
2.5 LIST OF EQUIPMENTS USED	10
3. SUMMARY OF TEST RESULTS	11
4. ETSI EN 301 908-1/-2 REQUIREMENTS	14
4.1. TRANSMITTER MAXIMUM OUTPUT POWER	14
4.2. TRANSMITTER SPECTRUM EMISSION MASK	16
4.3. TRANSMITTER SPECTRUM EMISSION MASK WITH HS-DPCCH	18
4.4. TRANSMITTER SPURIOUS EMISSIONS (UE)	20
4.5. TRANSMITTER MINIMUM OUTPUT POWER	24
4.6. TRANSMITTER ADJACENT CHANNEL LEAKAGE POWER RATIO	25
4.7. RECEIVER SPURIOUS EMISSIONS	26
4.8. RECEIVER ADJACENT CHANNEL SELECTIVITY (ACS)	28
4.9. RECEIVER BLOCKING CHARACTERISTICS	29
4.10. RECEIVER SPURIOUS RESPONSE	32
4.11. RECEIVER INTERMODULATION CHARACTERISTICS	33
4.12. OUT-OF-SYNCHRONIZATION HANDLING OF OUTPUT POWER	35
4.13. RECEIVER REFERENCE SENSITIVITY LEVEL	37
4.14. CONTROL AND MONITORING FUNCTIONS (UE)	39
4.15. RADIATED EMISSIONS (UE)	40
4.16. Receiver Total Radiated Sensitivity (TRS)	46
4.17. Total Radiated Power (TRP)	46
5. APPENDIX I: PHOTOGRAPHS OF TEST SETUP	47

1. PRODUCT INFORMATION

1.1. PRODUCT TECHNICAL DESCRIPTION

Details of technical specification refer to the description in follows:

EUT Name:	Tablet
Model No:	Active 6
Serial Model:	N/A
Difference Description	N/A
Brand Name:	Blackview
Supported type	UMTS
Hardware Version	DK051-T616-V1.0
Software Version	Active6_EEA_T30_V1.0_20230711V01
Frequency Bands	<input checked="" type="checkbox"/> FDD Band I <input checked="" type="checkbox"/> FDD Band VIII (EU Bands) <input checked="" type="checkbox"/> FDD Band V <input checked="" type="checkbox"/> FDD Band II (Non-EU Bands)
Operation Frequency Range	TX: 1922.6MHz~1977.4MHz (FDD Band I) TX: 882.6MHz~912.4MHz (FDD Band VIII)
	RX: 2112.6MHz~2167.4MHz (FDD Band I) RX: 927.6MHz~957.4MHz (FDD Band VIII)
Modulation Type	HSDPA: QPSK/16QAM; HSUPA: BPSK; WCDMA: QPSK
Power Class	3
GSM Release Version	R99
WCDMA Release Version	Release 6 and later
Antenna Type	PIFA Antenna
Antenna Gain	FDD Band I:1.21dBi FDD Band VIII:0.67dBi
SIM Card Description	There are dual-SIM cards for UMTS.
Power Supply	3.87V 13000mAh form battery

Note:

1. The above information was declared by the manufacturer.
2. The equipment submitted representative production models.
3. For more details, please refer to the User's manual of the EUT.

1.2. DESCRIPTION OF TEST MODES AND TEST FREQUENCY

Bands	Sub-test	Channel	Frequency (MHz)	
WCDMA Band I	---	9613	Low	1922.6
		9750	Mid	1950.0
		9887	High	1977.4
WCDMA Band VIII	---	2713	Low	882.6
		2788	Mid	897.6
		2863	High	912.4

1.3. OBJECTIVE

Perform Radio Spectrum tests for CE Marking according to the provisions of article 3.2 of the Radio Equipment Directive (2014/53/EU) for the GSM function of the EUT.

1.4. TEST ITEMS AND THE RESULTS

Leading reference documents for testing:

ETSI EN 301 908-1	IMT cellular networks; Harmonised Standard for access to radio spectrum; Part 1: Introduction and common requirements Release 15
ETSI EN 301 908-2	IMT cellular networks; Harmonised Standard for access to radio spectrum; Part 2: CDMA Direct Spread (UTRA FDD) User Equipment (UE)

Specific reference documents for testing:

3GPP TS 34.121-1	3rd Generation Partnership Project; Technical Specification Group Radio Access Network; Terminal conformance specification; Radio transmission and reception (FDD)
3GPP TS 34.121-2	3rd Generation Partnership Project; Technical Specification Group Radio Access Network User Equipment (UE) conformance specification; Radio transmission and reception (FDD); Part 2: Implementation Conformance Statement (ICS)

Technical requirements specifications for transmitter/ receiver ETSI EN 301 908-1 V15.1.1 (2021-09) & ETSI EN 301 908-2 V13.1.1 (2020-06)			
Ref.	Subclause	Test Item	Result
4.1	4.2.2	Transmitter Maximum Output Power	Pass
4.2	4.2.3	Transmitter Spectrum Emission Mask	Pass
4.3	4.2.4	Transmitter Spurious Emissions	Pass
4.4	4.2.5	Transmitter Minimum Output Power	Pass
4.5	4.2.6	Receiver Adjacent Channel Selectivity (ACS)	Pass
4.6	4.2.7	Receiver Blocking Characteristics	Pass
4.7	4.2.8	Receiver Spurious Response	Pass
4.8	4.2.9	Receiver Intermodulation Characteristics	Pass
4.9	4.2.10	Receiver Spurious Emissions	Pass
4.10	4.2.11	Out-Of-Synchronization Handling of Output Power	Pass
4.11	4.2.12	Transmitter Adjacent Channel Leakage Power Ratio (ACLR)	Pass
4.12	4.2.13	Receiver Reference Sensitivity Level	Pass
4.21	4.2.2	Radiated Emissions (UE)	Pass
4.22	4.2.4	Control And Monitoring Functions (UE)	Pass
-	4.2.14	Receiver Total Radiated Sensitivity (TRS)	N/A (Note 4)
-	4.2.15	Total Radiated Power (TRP)	N/A (Note 4)

Note:

- 1.The measurement uncertainty is not included in the test result.
- 2.N/A: means this test item is not applicable for this device according to the technology characteristic of device.
- 3.EUT Orthogonal Axis: “X” - denotes Laid on Table; “Y” - denotes Vertical Stand; “Z” - denotes Side Stand.
- 4.This requirement applies to handheld phones/DUTs with a width ranging from 56mm-72mm.

1.5. TYPE OF MOBILE STATION AND ADDITIONAL INFORMATION

Item	Release	FDD (DS) RF Baseline Implementation capabilities	Support	Allowed Value	Comments
1	R99	Chip rate 3.84 Mbps	YES	Yes/No	--
2	R99	Frequency band: 1920-1980, 2110-2170 MHz	YES	Yes/No	Band I
3	R99	Frequency band: 1850-1910, 1930-1990 MHz	YES	Yes/No	Band II
9	R99	UE Power Class 1 (+33 dBm)	NO	Yes/No	--
10	R99	UE Power Class 2 (+27 dBm)	NO	Yes/No	--
11	R99	UE Power Class 3 (+24 dBm)	YES	Yes/No	--
12	R99	UE Power Class 4 (+21 dBm)	NO	Yes/No	--
14	R99	Frequency band: 1710-1785, 1805-1880 MHz	NO	Yes/No	Band III
15	R99	Frequency band: 1710-1755, 2110-2155 MHz	NO	Yes/No	Band IV
16	R99	Frequency band: 824-849, 869-894 MHz	YES	Yes/No	Band V
17	R99	Frequency band: 830-840, 875-885 MHz	NO	Yes/No	Band VI
18	R99	Frequency band: 2500-2570, 2620-2690 MHz	NO	Yes/No	Band VII
19	R99	Frequency band: 880-915, 925-960 MHz	YES	Yes/No	Band VIII
20	R99	Frequency band: 1749.9-1784.9, 1844.9-1879.9 MHz	NO	Yes/No	Band IX
21	R99	Frequency band: 1710-1770, 2110-2170 MHz	NO	Yes/No	Band X
22	R99	Frequency band: 1427.9-1452.9, 1475.9-1500.9 MHz	NO	Yes/No	Band XI
23	R99	Frequency band: 698-716, 728-746 MHz	NO	Yes/No	Band XII
24	R99	Frequency band: 777-787, 746-756 MHz	NO	Yes/No	Band XIII
25	R99	Frequency band: 788-798, 758-768 MHz	NO	Yes/No	Band XIV

2. TEST ENVIRONMENT

2.1 ADDRESS OF THE TEST LABORATORY

Test Site	Dongguan Yaxu (AiT) Technology Limited
Location	Add: No.22, Jinqianling 3rd Street, Jitigang, Huangjiang, Dongguan, Guangdong, China
CNAS- Registration No	L6177

2.2 ENVIRONMENTAL CONDITIONS

	NORMAL CONDITIONS	EXTREME CONDITIONS
Temperature range (°C)	15 - 35	-10 - 50
Relative humidity range	20 % - 75 %	20 % - 75 %
Pressure range (kPa)	86 - 106	86 - 106
Power supply	DC 3.87V	LV:DC 3.483V/HV: DC 4.257V

Note: 1.The Extreme Temperature and Extreme Voltages declared by the manufacturer.
 2.The Limit Voltage 4.40V was declared by manufacturer,
 3.The EUT couldn't be operate normally with higher voltage.
 4.The maximum temperature of 40 is not a standard requirement and is measured according to the maximum service temperature stated by the manufacturer.

2.2 SETUP CONFIGURATION OF EUT

Conducted measurements configuration of EUT shall be as follows:

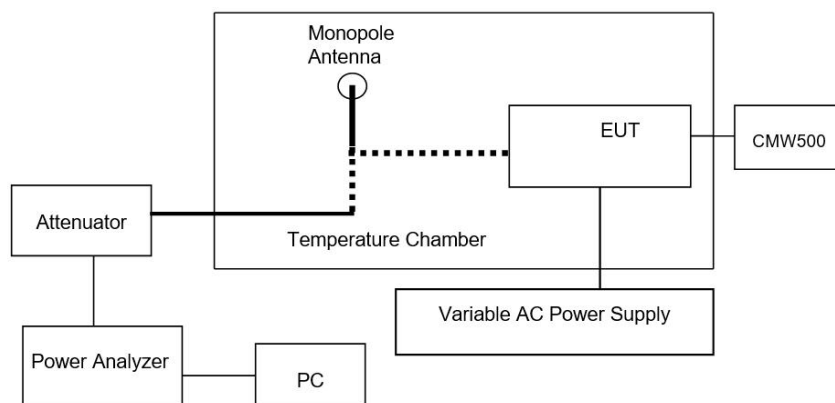

Remarks:

The Signal Analyzer could be connected to a monopole antenna or directly connected to the EUT, if the EUT has already employing an antenna connector.

2.4 MEASUREMENT UNCERTAINTY

The reported uncertainty of measurement $y \pm U$, where expanded uncertainty U is based on a standard uncertainty multiplied by a coverage factor of $k=2$, providing a level of confidence of approximately 95%.

Parameter	Conditions	Test System Uncertainty
Transmitter Maximum Output power	--	$\pm 0,6$ dB
Transmitter spectrum emissions mask	--	$\pm 1,4$ dB
Transmitter spurious emissions	$f \leq 2,2$ GHz	$\pm 1,35$ dB
	$2,2$ GHz $< f \leq 4$ GHz	± 1.8 dB
	$f > 4$ GHz	± 3.5 dB
	Co-existence band (≥ -60 dBm)	± 1.8 dB
	Co-existence band (< -60 dBm)	± 2.7 dB
Transmitter Minimum output power	--	± 0.8 dB
Receiver Adjacent Channel Selectivity(ACS)	--	± 0.9 dB
Receiver Blocking characteristics	$f < 15$ MHz offset:	$\pm 1,1$ dB
	15 MHz offset $\leq f \leq 2,2$ GHz	± 0.8 dB
	$2,2$ GHz $< f \leq 4$ GHz	$\pm 1,5$ dB
	$f > 4$ GHz	± 2.9 dB
Receiver spurious response	$f \leq 2,2$ GHz	± 0.8 dB
	$2,2$ GHz $< f \leq 4$ GHz	$\pm 1,5$ dB
	$f > 4$ GHz	± 2.9 dB
Receiver intermodulation characteristics	--	$\pm 1,2$ dB
Receiver spurious emissions	For UE receive band (-60 dBm)	± 2.8 dB
	For UE transmit band (-60 dBm)	± 2.9 dB
	Outside the UE receive band:	± 1.8 dB
	$f \leq 2,2$ GHz	± 1.7 dB
	$2,2$ GHz $< f \leq 4$ GHz	± 3.6 dB
Out of synchronization of handing power	DPCCH Ec/Ior	$\pm 0,3$ dB
	Transmit OFF power	± 0.8 dB
Transmitter adjacent channel leakage power ratio	--	$\pm 0,7$ dB
Effective radiated RF power between 30 MHz and 180 MHz	--	± 5 dB
Effective radiated RF power between 180 MHz and 12,75 GHz	--	± 2 dB
Conducted RF power	--	± 0.9 dB

2.5 LIST OF EQUIPMENTS USED

No	Test Equipment	Manufacturer	Model No	Serial No	Cal. Date	Cal. Due Date
1	Spectrum Analyzer	R&S	FSV40	101470	2022.09.02	2023.09.01
2	EMI Measuring Receiver	R&S	ESR	101660	2022.09.02	2023.09.01
3	Low Noise Pre Amplifier	HP	HP8447E	1937AIT2307 1306-1855	2022.09.02	2023.09.01
4	Low Noise Pre Amplifier	Tsj	MLA-0120-A0 2-34	2648A04738	2022.09.02	2023.09.01
5	Passive Loop	ETS	6512	00165355	2022.09.03	2024.09.02
6	TRILOG Super Broadband test Antenna	SCHWARZBECK	VULB9160	9160-3206	2021.08.29	2024.08.28
7	Broadband Horn Antenna	SCHWARZBECK	BBHA9120D	452	2021.08.29	2024.08.28
8	SHF-EHF Horn Antenna 15-40GHz	SCHWARZBECK	BBHA9170	BBHA917036 7d	2020.11.24	2023.11.23
9	EMI Test Receiver	R&S	ESCI	100124	2022.09.02	2023.09.01
10	LISN	Kyoritsu	KNW-242	8-837-4	2022.09.02	2023.09.01
11	LISN	R&S	ESH3-Z2	0357.8810.54- 101161-S2	2022.09.02	2023.09.01
12	Pro.Temp&Humi.chamber	MENTEK	MHP-150-1C	MAA0811250 1	2022.09.02	2023.09.01
13	RF Automatic Test system	MW	MW100-RFCB	21033016	2022.09.02	2023.09.01
14	Signal Generator	Agilent	N5182A	MY50143009	2022.09.02	2023.09.01
15	Wideband Radio communication tester	R&S	CMW500	1201.0002K5 0	2022.09.02	2023.09.01
16	RF Automatic Test system	MW	MW100-RFCB	21033016	2022.09.02	2023.09.01
17	DC power supply	ZHAOXIN	RXN-305D-2	28070002559	N/A	N/A
18	RE Software	EZ	EZ-EMC_RE	Ver.AIT-03A	N/A	N/A
19	CE Software	EZ	EZ-EMC_CE	Ver.AIT-03A	N/A	N/A
20	RF Software	MW	MTS 8310	2.0.0.0	N/A	N/A
21	temporary antenna connector(Note)	NTS	R001	N/A	N/A	N/A
22	Spectrum Analyzer	Agilent	N9020A	MT21033052	2022.09.02	2023.09.01

Note: The temporary antenna connector is soldered on the PCB board in order to perform conducted tests and this temporary antenna connector is listed in the equipment list.

3. SUMMARY OF TEST RESULTS

Terms in the column “Verdict” for the test results list of the section:

Verdict	Description
PASS	EUT passed this test case
FAIL	EUT failed this test case
INC.	EUT did not pass and did not fail this test case, therefore the verdict is inconclusive
N/A	Test case not applicable for the EUT, see the column “Note” for detailed

ETSI EN 301 908-1

Test case	Description	Condition	FDDI		FDDVIII	
			Sample	Result	Sample	Result
5.3.1	Radiated emission (UE)	NTC	AIT2307 1306-1	PASS	AIT230 71306-1	PASS
5.3.3	Control and monitoring functions (UE)	NTC	AIT2307 1306-1	PASS	AIT230 71306-1	PASS

ETSI EN 301 908-2

Test case	Description	Condition	FDDI		FDDVIII	
			Sample	Result	Sample	Result
4.2.2	Transmitter Characteristics/Maximum Output Power	NTC	AIT2307 1306-1	PASS	AIT230 71306-1	PASS
4.2.2	Transmitter Characteristics/Maximum Output Power	HT/HV	AIT2307 1306-1	PASS	AIT230 71306-1	PASS
4.2.2	Transmitter Characteristics/Maximum Output Power	HT/LV	AIT2307 1306-1	PASS	AIT230 71306-1	PASS
4.2.2	Transmitter Characteristics/Maximum Output Power	LT/HV	AIT2307 1306-1	PASS	AIT230 71306-1	PASS
4.2.2	Transmitter Characteristics/Maximum Output Power	LT/LV	AIT2307 1306-1	PASS	AIT230 71306-1	PASS
4.2.5	Transmitter Characteristics/Output Dynamics in the Uplink/Minimum Output Power	NTC	AIT2307 1306-1	PASS	AIT230 71306-1	PASS
4.2.5	Transmitter Characteristics/Output Dynamics in the Uplink/Minimum Output Power	HTHV	AIT2307 1306-1	PASS	AIT230 71306-1	PASS
4.2.5	Transmitter Characteristics/Output Dynamics in the Uplink/Minimum Output Power	HTLV	AIT2307 1306-1	PASS	AIT230 71306-1	PASS
4.2.5	Transmitter Characteristics/Output	LT/HV	AIT2307	PASS	AIT230	PASS

	Dynamics in the Uplink/Minimum Output Power		1306-1		71306-1	
4.2.5	Transmitter Characteristics/Output Dynamics in the Uplink/Minimum Output Power	LT/LV	AIT2307 1306-1	PASS	AIT230 71306-1	PASS
4.2.11	Transmitter Characteristics/Output Dynamics in the Uplink/Out-of-synchronization Handling of Output power	NTC	AIT2307 1306-1	PASS	AIT230 71306-1	PASS
4.2.3	Transmitter Characteristics/Spectrum Emission Mask	NTC	AIT2307 1306-1	PASS	AIT230 71306-1	PASS
4.2.3	Transmitter Characteristics/Spectrum Emission Mask-HSDPA&HSUPA	NTC	AIT2307 1306-1	PASS	AIT230 71306-1	PASS
4.2.12	Transmitter Characteristics/Adjacent Channel Leakage Power Ratio (ACLR)	NTC	AIT2307 1306-1	PASS	AIT230 71306-1	PASS
4.2.12	Transmitter Characteristics/Adjacent Channel Leakage Power Ratio (ACLR)	HT/HV	AIT2307 1306-1	PASS	AIT230 71306-1	PASS
4.2.12	Transmitter Characteristics/Adjacent Channel Leakage Power Ratio (ACLR)	HT/LV	AIT2307 1306-1	PASS	AIT230 71306-1	PASS
4.2.12	Transmitter Characteristics/Adjacent Channel Leakage Power Ratio (ACLR)	LT/HV	AIT2307 1306-1	PASS	AIT230 71306-1	PASS
4.2.12	Transmitter Characteristics/Adjacent Channel Leakage Power Ratio (ACLR)	LT/LV	AIT2307 1306-1	PASS	AIT230 71306-1	PASS
4.2.12	Transmitter Characteristics/Adjacent Channel Leakage Power Ratio (ACLR)-- HSDPA&HSUPA	NTC	AIT2307 1306-1	PASS	AIT230 71306-1	PASS
4.2.12	Transmitter Characteristics/Adjacent Channel Leakage Power Ratio (ACLR)-- HSDPA&HSUPA	HT/HV	AIT2307 1306-1	PASS	AIT230 71306-1	PASS
4.2.12	Transmitter Characteristics/Adjacent Channel Leakage Power Ratio (ACLR)-- HSDPA&HSUPA	HT/LV	AIT2307 1306-1	PASS	AIT230 71306-1	PASS
4.2.12	Transmitter Characteristics/Adjacent Channel Leakage Power Ratio	LT/HV	AIT2307 1306-1	PASS	AIT230 71306-1	PASS

	(ACLR)-- HSDPA&HSUPA					
4.2.12	Transmitter Characteristics/Adjacent Channel Leakage Power Ratio (ACLR)-- HSDPA&HSUPA	LT/LV	AIT2307 1306-1	PASS	AIT230 71306-1	PASS
4.2.4	Transmitter Characteristics/Spurious Emissions	NTC	AIT2307 1306-1	PASS	AIT230 71306-1	PASS
4.2.6	Receiver Characteristics/Adjacent Channel Selectivity (ACS)	NTC	AIT2307 1306-1	PASS	AIT230 71306-1	PASS
4.2.7	Receiver Characteristics/Blocking Characteristics	NTC	AIT2307 1306-1	PASS	AIT230 71306-1	PASS
4.2.8	Receiver Characteristics/Spurious Response	NTC	AIT2307 1306-1	PASS	AIT230 71306-1	PASS
4.2.9	Receiver Characteristics /Intermodulation Characteristics	NTC	AIT2307 1306-1	PASS	AIT230 71306-1	PASS
4.2.10	Receiver Characteristics/Spurious Emissions	NTC	AIT2307 1306-1	PASS	AIT230 71306-1	PASS
4.2.13	Receiver Reference Sensitivity level	NTC	AIT2307 1306-1	PASS	AIT230 71306-1	PASS
4.2.14	Receiver Total Radiated Sensitivity (TRS)	NTC	AIT2307 1306-1	NA	AIT230 71306-1	NA
4.2.15	Total Radiated Power (TRP)	NTC	AIT2307 1306-1	NA	AIT230 71306-1	NA

Note:

1. The test result is SIM Card 1 and recorded in the test report.
2. The device width is greater than 72mm and does not need to meet the OTA test.

4. ETSI EN 301 908-1/-2 REQUIREMENTS

4.1. TRANSMITTER MAXIMUM OUTPUT POWER

TEST LIMIT

ETSI EN 301 908-2 Sub-clause 4.2.2.1

Power Class 3	
Power (dBm)	Tol (dB)
+24	+1.7/-3.7

NOTE 1: These requirements do not take into account the maximum power reduction allowed to the UE in the presence of HS-DPCCH and E-DCH specified in TS 125 101 [5].

NOTE 2: The range of UE maximum output power for the various power classes are specified in TS 125 101 [5], clause 6.2.1. The values in table 4.2.2.2-1 correspond to the measurement limits taking into account the measurement uncertainty of measurement equipment (see clause 5.2).4.2.2.3 Conformance.

Table 5.2AA.2: Maximum Output Powers with HS-DPCCH for test

Sub-test in table C.10.1.4	Power Class 3		Power Class 4	
	Power (dBm)	Tol (dB)	Power (dBm)	Tol (dB)
1	+24	+1.7/-3.7	+21	+2.7/-2.7
2	+24	+1.7/-3.7	+21	+2.7/-2.7
3	+23.5	+2.2/-3.7	+20.5	+3.2/-2.7
4	+23.5	+2.2/-3.7	+20.5	+3.2/-2.7

NOTE: If the above Test Requirement differs from the Minimum Requirement then the Test Tolerance applied for this test is non-zero. The Test Tolerance for this test is defined in clause F.2 and the explanation of how the Minimum Requirement has been relaxed by the Test Tolerance is given in clause F.4.

Table 5.2B.5: Maximum Output Powers with HS-DPCCH and E-DCH for test

Sub-test in table C.11.1.3	Power Class 3		Power Class 4	
	Power (dBm)	Tol (dB)	Power (dBm)	Tol (dB)
1	+24	+1.7/-6.7	+21	+2.7/-5.7
2	+22	+3.7/-5.2	+19	+4.7/-4.2
3	+23	+2.7/-5.2	+20	+3.7/-4.2
4	+22	+3.7/-5.2	+19	+4.7/-4.2
5	+24	+1.7/-3.7	+21	+2.7/-2.7

NOTE 1: If the above Test Requirement differs from the Minimum Requirement then the Test Tolerance applied for this test is non-zero. The Test Tolerance for this test is defined in clause F.2 and the explanation of how the Minimum Requirement has been relaxed by the Test Tolerance is given in clause F.4.

NOTE 2: The test procedure for sub-test 1 to 4 will result in a power slightly below the maximum, and therefore the lower limits in Table 5.2B.5 are made lower by 1.5 dB.

NOTE 3: The test procedure allows UE to decrease its maximum transmit power for E-TFC selection in sub-test 1, and therefore the lower limits of sub-test 1 in Table 5.2B.5 are made lower by 1.5 dB.

NOTE 4: For subtests 2, 3 and 4, UE may perform E-DPCCH power scaling at max power which could results in slightly smaller MPR values.

TEST PROCEDURE

1. Set and send continuously Up power control commands to the UE.
2. Measure the mean power of the UE in a bandwidth of at least $(1 + \alpha)$ times the chip rate of the radio access mode. The mean power shall be averaged over at least one timeslot.

TEST RESULTS

Mode	Test Condition					Result
Band I	Normal	L.V. L.T.	L.V. H.T.	H.V L.T	H.V. H.T	Compliance
Band VIII	Normal	L.V. L.T.	L.V. H.T.	H.V L.T	H.V. H.T	Compliance

Note: All test modes were carried out for all operation modes and record the worst test mode (BAND I&BAND VIII TN/VN) of fellow:

Note: For test data, please refer to the AIT23071306CW7-WCDMA Test Data

MAIN MODEM

WCDMA Band I

Condition	Mode	Frequency (MHz)	Average Power (dBm)	Limit		Verdict
				Min	Max	
NTNV	RMC	1922.6	23.27	20.3	25.7	PASS
		1950.0	23.36	20.3	25.7	PASS
		1977.4	23.30	20.3	25.7	PASS

WCDMA Band VIII

Condition	Mode	Frequency (MHz)	Average Power (dBm)	Limit		Verdict
				Min	Max	
NTNV	RMC	882.6	23.36	20.3	25.7	PASS
		897.6	23.46	20.3	25.7	PASS
		912.4	23.35	20.3	25.7	PASS

4.2. TRANSMITTER SPECTRUM EMISSION MASK

TEST LIMIT

The power of any UE emission shall not exceed the levels specified in table 4.2.3.2-1. The requirements are applicable for all for the values of β_c , β_d , β_{hs} , β_{ec} and β_{ed} defined in TS 125 214 [8].

Table 4.2.3.2-1: Spectrum emission mask requirement

Δf in MHz (note 1)	Minimum requirement (note 2)		Measurement bandwidth (note 5)
	Relative requirement	Absolute requirement (in measurement bandwidth)	
2,5 MHz to 3,5 MHz	$\left\{ -33,5 - 15 \cdot \left(\frac{\Delta f}{MHz} - 2,5 \right) \right\} dBc$	-69,6 dBm	30 kHz (see note 3)
3,5 MHz to 7,5 MHz	$\left\{ -33,5 - 1 \cdot \left(\frac{\Delta f}{MHz} - 3,5 \right) \right\} dBc$	-54,3 dBm	1 MHz (see note 4)
7,5 MHz to 8,5 MHz	$\left\{ -37,5 - 10 \cdot \left(\frac{\Delta f}{MHz} - 7,5 \right) \right\} dBc$	-54,3 dBm	1 MHz (see note 4)
8,5 MHz to 12,5 MHz	-47,5 dBc	-54,3 dBm	1 MHz (see note 4)

NOTE 1: Δf is the separation between the carrier frequency and the centre of the measurement bandwidth.
 NOTE 2: The minimum requirement is calculated from the relative requirement or the absolute requirement, whichever is the higher power.
 NOTE 3: The first and last measurement position with a 30 kHz filter is at Δf equals to 2,515 MHz and 3,485 MHz.
 NOTE 4: The first and last measurement position with a 1 MHz filter is at Δf equals to 4 MHz and 12 MHz.
 NOTE 5: As a general rule, the resolution bandwidth of the measuring equipment should be equal to the measurement bandwidth. However, to improve measurement accuracy, sensitivity and efficiency, the resolution bandwidth may be smaller than the measurement bandwidth. When the resolution bandwidth is smaller than the measurement bandwidth, the result should be integrated over the measurement bandwidth in order to obtain the equivalent noise bandwidth of the measurement bandwidth.

TEST PROCEDURE

- 1) Set and send continuously Up power control commands to the UE until the UE output power shall be at the maximum level.
- 2) Measure the power of the transmitted signal with a measurement filter of bandwidths according to table 4.2.3.2-1. Measurements with an offset from the carrier centre frequency between 2,515 MHz and 3,485 MHz shall use a 30 kHz measurement filter. Measurements with an offset from the carrier centre frequency between 4 MHz and 12 MHz shall use 1 MHz measurement bandwidth and the result may be calculated by integrating multiple 50 kHz or narrower filter measurements. The characteristic of the filter shall be approximately Gaussian (typical spectrum analyzer filter). The centre frequency of the filter shall be stepped in contiguous steps according to table 4.2.3.2-1. The measured power shall be recorded for each step.
- 3) Measure the RRC filtered mean power centred on the assigned channel frequency.
- 4) Calculate the ratio of the power 2) with respect to 3) in dBc.

TEST RESULTS

MAIN MODEM

Mode	Test Frequency (MHz)	Test Condition					Result
Band I	1922.6	Normal	L.V. L.T.	L.V. H.T.	H.V L.T	H.V. H.T	Compliance
	1950.0	Normal	L.V. L.T.	L.V. H.T.	H.V L.T	H.V. H.T	Compliance
	1977.4	Normal	L.V. L.T.	L.V. H.T.	H.V L.T	H.V. H.T	Compliance
Band VIII	882.6	Normal	L.V. L.T.	L.V. H.T.	H.V L.T	H.V. H.T	Compliance
	897.6	Normal	L.V. L.T.	L.V. H.T.	H.V L.T	H.V. H.T	Compliance
	912.4	Normal	L.V. L.T.	L.V. H.T.	H.V L.T	H.V. H.T	Compliance

Note: For test data, please refer to the AIT23071306CW7-WCDMA Test Data

4.3. TRANSMITTER SPECTRUM EMISSION MASK WITH HS-DPCCH

TEST LIMIT

Table 5.9A.1: Spectrum Emission Mask Requirement

Δf in MHz (Note 1)	Minimum requirement (Note 2)		Measurement bandwidth
	Relative requirement	Absolute requirement	
2.5 - 3.5	$\left\{ -35 - 15 \cdot \left(\frac{\Delta f}{MHz} - 2.5 \right) \right\} dBc$	-71.1 dBm	30 kHz (Note 3)
3.5 - 7.5	$\left\{ -35 - 1 \cdot \left(\frac{\Delta f}{MHz} - 3.5 \right) \right\} dBc$	-55.8 dBm	1 MHz (Note 4)
7.5 - 8.5	$\left\{ -39 - 10 \cdot \left(\frac{\Delta f}{MHz} - 7.5 \right) \right\} dBc$	-55.8 dBm	1 MHz (Note 4)
8.5 - 12.5 MHz	-49 dBc	-55.8 dBm	1 MHz (Note 4)
Note 1: Δf is the separation between the carrier frequency and the centre of the measurement bandwidth. Note 2: The minimum requirement is calculated from the relative requirement or the absolute requirement, whichever is the higher power. Note 3: The first and last measurement position with a 30 kHz filter is at Δf equals to 2.515 MHz and 3.485 MHz. Note 4: The first and last measurement position with a 1 MHz filter is at Δf equals to 4 MHz and 12 MHz.			

TEST PROCEDURE

- 1) Set and send continuously Up power control commands to the UE until the UE output power shall be at the maximum level.
- 2) Measure the power of the transmitted signal with a measurement filter of bandwidths according to table 5.9A.1. Measurements with an offset from the carrier centre frequency between 2,515 MHz and 3,485 MHz shall use a 30 kHz measurement filter. Measurements with an offset from the carrier centre frequency between 4 MHz and 12 MHz shall use 1 MHz measurement bandwidth and the result may be calculated by integrating multiple 50 kHz or narrower filter measurements. The characteristic of the filter shall be approximately Gaussian (typical spectrum analyzer filter). The centre frequency of the filter shall be stepped in contiguous steps according to table 5.9A.1. The measured power shall be recorded for each step.
- 3) Measure the RRC filtered mean power centred on the assigned channel frequency.
- 4) Calculate the ratio of the power 2) with respect to 3) in dBc.

TEST RESULTS

MAIN MODEM

Mode	Test Frequency (MHz)	Test Condition					Result
Band I	1922.6	Normal	L.V. L.T.	L.V. H.T.	H.V L.T	H.V. H.T	Compliance
	1950.0	Normal	L.V. L.T.	L.V. H.T.	H.V L.T	H.V. H.T	Compliance
	1977.4	Normal	L.V. L.T.	L.V. H.T.	H.V L.T	H.V. H.T	Compliance
Band VIII	882.6	Normal	L.V. L.T.	L.V. H.T.	H.V L.T	H.V. H.T	Compliance
	897.6	Normal	L.V. L.T.	L.V. H.T.	H.V L.T	H.V. H.T	Compliance
	912.4	Normal	L.V. L.T.	L.V. H.T.	H.V L.T	H.V. H.T	Compliance

Note: For test data, please refer to the AIT23071306CW7-WCDMA Test Data

4.4. TRANSMITTER SPURIOUS EMISSIONS (UE)

TEST LIMIT

The power of spurious emissions shall not exceed the limits defined in tables 4.2.4.1.2-1 and 4.2.4.1.2-2. The limits shown in tables 4.2.4.1.2-1 and 4.2.4.1.2-2 are only applicable for frequencies, which are greater than 12,5 MHz away from the UE centre carrier frequency.

Table 4.2.4.1.2-1: General spurious emissions requirements

Frequency bandwidth	Measurement bandwidth	Minimum requirement
9 kHz ≤ f < 150 kHz	1 kHz	-36 dBm
150 kHz ≤ f < 30 MHz	10 kHz	-36 dBm
30 MHz ≤ f < 1 000 MHz	100 kHz	-36 dBm
1 GHz ≤ f < 12,75 GHz	1 MHz	-30 dBm
12,75 GHz ≤ f < 5 th harmonic of the upper frequency edge of the UL operating band in GHz	1 MHz	-30 dBm (note)

NOTE: Applies only for Band XXII.

Table 4.2.4.1.2-2: Additional spurious emissions requirements

Operating band	Frequency bandwidth	Measurement bandwidth	Minimum requirement	
I	462,5 MHz ≤ f ≤ 467,5 MHz	1 MHz	-50 dBm	
	791 MHz ≤ f ≤ 821 MHz	3,84 MHz	-60 dBm	
	921 MHz ≤ f < 925 MHz	100 kHz	-60 dBm (note 1)	
	925 MHz ≤ f ≤ 935 MHz	100 kHz	-67 dBm (note 1)	
	935 MHz < f ≤ 960 MHz	100 kHz	-79 dBm (note 1)	
		3,84 MHz	-60 dBm	
	1 805 MHz ≤ f ≤ 1 880 MHz	100 kHz	-71 dBm (note 1)	
		3,84 MHz	-60 dBm	
	2 010 MHz < f < 2 025 MHz	3,84 MHz	-60 dBm	
2 110 MHz ≤ f ≤ 2 170 MHz	3,84 MHz	-60 dBm		
2 300 MHz ≤ f ≤ 2 400 MHz	3,84 MHz	-60 dBm		
2 585 MHz ≤ f ≤ 2 690 MHz	3,84 MHz	-60 dBm		
III	462,5 MHz ≤ f ≤ 467,5 MHz	1 MHz	-50 dBm	
	791 MHz ≤ f ≤ 821 MHz	3,84 MHz	-60 dBm	
	921 MHz ≤ f < 925 MHz	100 kHz	-60 dBm (note 1)	
	925 MHz ≤ f ≤ 935 MHz	100 kHz	-67 dBm (note 1)	
	935 MHz < f ≤ 960 MHz	100 kHz	-79 dBm (note 1)	
	1 805 MHz ≤ f ≤ 1 880 MHz	3,84 MHz	-60 dBm	
	1 880 MHz ≤ f ≤ 1 920 MHz	3,84 MHz	-60 dBm	
	2 010 MHz < f < 2 025 MHz	3,84 MHz	-60 dBm	
	2 110 MHz ≤ f ≤ 2 170 MHz	3,84 MHz	-60 dBm	
	2 300 MHz ≤ f ≤ 2 400 MHz	3,84 MHz	-60 dBm	
	2 585 MHz ≤ f ≤ 2 690 MHz	3,84 MHz	-60 dBm	
	VII	462,5 MHz ≤ f ≤ 467,5 MHz	1 MHz	-50 dBm
		729 MHz ≤ f ≤ 746 MHz	3,84 MHz	-60 dBm
746 MHz ≤ f ≤ 756 MHz		3,84 MHz	-60 dBm	
758 MHz ≤ f ≤ 768 MHz		3,84 MHz	-60 dBm	
859 MHz ≤ f ≤ 894 MHz		3,84 MHz	-60 dBm	
921 MHz ≤ f < 925 MHz		100 kHz	-60 dBm (note 1)	
925 MHz ≤ f ≤ 935 MHz		100 kHz	-67 dBm (note 1)	
935 MHz < f ≤ 960 MHz		100 kHz	-79 dBm (note 1)	
		3,84 MHz	-60 dBm	
1 805 MHz ≤ f ≤ 1 880 MHz		100 kHz	-71 dBm (note 1)	
		3,84 MHz	-60 dBm	
1 900 MHz ≤ f ≤ 1 920 MHz		3,84 MHz	-60 dBm	
1 930 MHz ≤ f ≤ 1 995 MHz		3,84 MHz	-60 dBm	
2 010 MHz < f < 2 025 MHz		3,84 MHz	-60 dBm	
2 110 MHz ≤ f ≤ 2 170 MHz		3,84 MHz	-60 dBm	
2 300 MHz < f < 2 400 MHz		3,84 MHz	-60 dBm	
2 350 MHz ≤ f ≤ 2 360 MHz		1 MHz	-50 dBm	
2 620 MHz ≤ f ≤ 2 690 MHz		3,84 MHz	-60 dBm	
2 595 MHz ≤ f ≤ 2 620 MHz		1 MHz	-40 dBm	

Operating band	Frequency bandwidth	Measurement bandwidth	Minimum requirement
VIII	$791 \text{ MHz} \leq f \leq 821 \text{ MHz}$	3,84 MHz	-60 dBm
	$925 \text{ MHz} \leq f \leq 935 \text{ MHz}$	100 kHz 3,84 MHz	-67 dBm (note 1) -60 dBm
	$935 \text{ MHz} < f \leq 960 \text{ MHz}$	100 kHz 3,84 MHz	-79 dBm (note 1) -60 dBm
	$1\ 805 \text{ MHz} < f \leq 1\ 830 \text{ MHz}$	100 kHz 3,84 MHz	-71 dBm (notes 1 and 2) -60 dBm (note 2)
	$1\ 830 \text{ MHz} < f \leq 1\ 880 \text{ MHz}$	100 kHz 3,84 MHz	-71 dBm (note 1) -60 dBm
	$1\ 880 \text{ MHz} \leq f \leq 1\ 920 \text{ MHz}$	3,84 MHz	-60 dBm
	$2\ 010 \text{ MHz} \leq f \leq 2\ 025 \text{ MHz}$	3,84 MHz	-60 dBm
	$2\ 110 \text{ MHz} \leq f \leq 2\ 170 \text{ MHz}$	3,84 MHz	-60 dBm
	$2\ 300 \text{ MHz} < f < 2\ 400 \text{ MHz}$	3,84 MHz	-60 dBm
	$2\ 585 \text{ MHz} \leq f \leq 2\ 640 \text{ MHz}$	3,84 MHz	-60 dBm
XV	$2\ 640 \text{ MHz} \leq f \leq 2\ 690 \text{ MHz}$	3,84 MHz	-60 dBm (note 2)
	$791 \text{ MHz} \leq f \leq 821 \text{ MHz}$	3,84 MHz	-60 dBm
	$921 \text{ MHz} \leq f \leq 925 \text{ MHz}$	100 kHz	-60 dBm (note 1)
	$925 \text{ MHz} \leq f \leq 935 \text{ MHz}$	100 kHz 3,84 MHz	-67 dBm (note 1) -60 dBm
	$935 \text{ MHz} \leq f \leq 960 \text{ MHz}$	100 kHz	-79 dBm (note 1)
	$1\ 805 \text{ MHz} \leq f \leq 1\ 880 \text{ MHz}$	100 kHz	-71 dBm (note 1)
	$2\ 110 \text{ MHz} \leq f \leq 2\ 170 \text{ MHz}$	3,84 MHz	-60 dBm
	$2\ 585 \text{ MHz} \leq f \leq 2\ 620 \text{ MHz}$	3,84 MHz	-50 dBm
XVI	$2\ 620 \text{ MHz} \leq f \leq 2\ 690 \text{ MHz}$	3,84 MHz	-60 dBm
	$791 \text{ MHz} \leq f \leq 821 \text{ MHz}$	3,84 MHz	-60 dBm
	$921 \text{ MHz} \leq f \leq 925 \text{ MHz}$	100 kHz	-60 dBm (note 1)
	$925 \text{ MHz} \leq f \leq 935 \text{ MHz}$	100 kHz 3,84 MHz	-67 dBm (note 1) -60 dBm
	$935 \text{ MHz} \leq f \leq 960 \text{ MHz}$	100 kHz	-79 dBm (note 1)
	$1\ 805 \text{ MHz} \leq f \leq 1\ 880 \text{ MHz}$	100 kHz	-71 dBm (note 1)
	$2\ 110 \text{ MHz} \leq f \leq 2\ 170 \text{ MHz}$	3,84 MHz	-60 dBm
	$2\ 585 \text{ MHz} \leq f \leq 2\ 620 \text{ MHz}$	3,84 MHz	-50 dBm
XX	$2\ 620 \text{ MHz} \leq f \leq 2\ 690 \text{ MHz}$	3,84 MHz	-60 dBm
	$470 \text{ MHz} \leq f \leq 790 \text{ MHz}$	8 MHz	-65 dBm (note 3)
	$758 \text{ MHz} \leq f \leq 788 \text{ MHz}$	1 MHz	-50 dBm
	$791 \text{ MHz} \leq f \leq 821 \text{ MHz}$	3,84 MHz	-60 dBm
	$921 \text{ MHz} \leq f \leq 925 \text{ MHz}$	100 kHz	-60 dBm (note 1)
	$925 \text{ MHz} \leq f \leq 935 \text{ MHz}$	100 kHz 3,84 MHz	-67 dBm (note 1) -60 dBm
	$935 \text{ MHz} \leq f \leq 960 \text{ MHz}$	100 kHz 3,84 MHz	-79 dBm (note 1) -60 dBm
	$1\ 805 \text{ MHz} \leq f \leq 1\ 880 \text{ MHz}$	100 kHz 3,84 MHz	-71 dBm (note 1) -60 dBm
	$2\ 010 \text{ MHz} \leq f \leq 2\ 025 \text{ MHz}$	3,84 MHz	-60 dBm
	$2\ 110 \text{ MHz} \leq f \leq 2\ 170 \text{ MHz}$	3,84 MHz	-60 dBm
	$2\ 300 \text{ MHz} \leq f \leq 2\ 400 \text{ MHz}$	3,84 MHz	-60 dBm
	$2\ 585 \text{ MHz} \leq f \leq 2\ 620 \text{ MHz}$	3,84 MHz	-50 dBm
	$2\ 620 \text{ MHz} \leq f \leq 2\ 690 \text{ MHz}$	3,84 MHz	-60 dBm

Operating band	Frequency bandwidth	Measurement bandwidth	Minimum requirement
XXII	$791 \text{ MHz} \leq f \leq 821 \text{ MHz}$	3,84 MHz	-60 dBm
	$921 \text{ MHz} \leq f < 925 \text{ MHz}$	100 kHz	-60 dBm (note 1)
	$925 \text{ MHz} \leq f \leq 935 \text{ MHz}$	100 kHz 3,84 MHz	-67 dBm (note 1) -60 dBm
	$935 \text{ MHz} < f \leq 960 \text{ MHz}$	100 kHz 3,84 MHz	-79 dBm (note 1) -60 dBm
	$1\ 805 \text{ MHz} \leq f \leq 1\ 880 \text{ MHz}$	100 kHz 3,84 MHz	-71 dBm (note 1)
	$2\ 110 \text{ MHz} \leq f \leq 2\ 170 \text{ MHz}$	3,84 MHz	-60 dBm
	$2\ 585 \text{ MHz} \leq f \leq 2\ 620 \text{ MHz}$	3,84 MHz	-50 dBm
	$2\ 620 \text{ MHz} \leq f \leq 2\ 690 \text{ MHz}$	3,84 MHz	-60 dBm
	$3\ 510 \text{ MHz} \leq f \leq 3\ 525 \text{ MHz}$	1 MHz	-40 dBm
	$3\ 525 \text{ MHz} \leq f \leq 3\ 590 \text{ MHz}$	1 MHz	-50 dBm
	$3\ 600 \text{ MHz} \leq f \leq 3\ 800 \text{ MHz}$	3,84 MHz	-50 dBm
<p>NOTE 1: The transmitter additional spurious emission measurements are made on frequencies which are integer multiples of 200 kHz. As exceptions, up to five measurements with a level up to the applicable requirements defined in table 4.2.4.1.2-1 are permitted for each UARFCN used in the measurement.</p> <p>NOTE 2: The transmitter additional spurious emission measurements are made on frequencies which are integer multiples of 200 kHz. As exceptions, measurements with a level up to the applicable requirements defined in table 4.2.4.1.2-1 are permitted for each UARFCN used in the measurement due to 2nd, 3rd and 4th harmonic spurious emissions.</p> <p>NOTE 3: The conformance shall be assessed using the measurement position placed at the following centre frequencies: 474 MHz, 586 MHz, 690 MHz, 754 MHz, 770 MHz and 786 MHz.</p>			

TEST PROCEDURE

- 1) Set and send continuously Up power control commands to the UE until the UE output power shall be maximum level.
- 2) Sweep the spectrum analyses (or equivalent equipment) over a frequency range and measure the average power of spurious emission.

TEST RESULTS

MAIN MODEM

Mode	Test Frequency (MHz)	Test Condition					Result
Band I	1922.6	Normal	L.V. L.T.	L.V. H.T.	H.V L.T	H.V. H.T	Compliance
	1950.0	Normal	L.V. L.T.	L.V. H.T.	H.V L.T	H.V. H.T	Compliance
	1977.4	Normal	L.V. L.T.	L.V. H.T.	H.V L.T	H.V. H.T	Compliance
Band VIII	882.6	Normal	L.V. L.T.	L.V. H.T.	H.V L.T	H.V. H.T	Compliance
	897.6	Normal	L.V. L.T.	L.V. H.T.	H.V L.T	H.V. H.T	Compliance
	912.4	Normal	L.V. L.T.	L.V. H.T.	H.V L.T	H.V. H.T	Compliance

Note: For test data, please refer to the AIT23071306CW7-WCDMA Test Data

4.5. TRANSMITTER MINIMUM OUTPUT POWER

TEST LIMIT

The minimum output power shall be less than -49 dBm.

TEST PROCEDURE

- 1) Set and send continuously Down power control commands to the UE.
- 2) Measure the mean power of the UE.

TEST RESULTS

MAIN MODEM

Mode	Test Frequency (MHz)	Test Condition					Result
Band I	1922.6	Normal	L.V. L.T.	L.V. H.T.	H.V L.T	H.V. H.T	Compliance
	1950.0	Normal	L.V. L.T.	L.V. H.T.	H.V L.T	H.V. H.T	Compliance
	1977.4	Normal	L.V. L.T.	L.V. H.T.	H.V L.T	H.V. H.T	Compliance
Band VIII	882.6	Normal	L.V. L.T.	L.V. H.T.	H.V L.T	H.V. H.T	Compliance
	897.6	Normal	L.V. L.T.	L.V. H.T.	H.V L.T	H.V. H.T	Compliance
	912.4	Normal	L.V. L.T.	L.V. H.T.	H.V L.T	H.V. H.T	Compliance

Note: For test data, please refer to the AIT23071306CW7-WCDMA Test Data

4.6. TRANSMITTER ADJACENT CHANNEL LEAKAGE POWER RATIO

TEST LIMIT

If the adjacent channel power is greater than -50 dBm then the ACLR shall be higher than the value specified in table 4.2.12.2-1. The requirements are applicable for all for the values of β_c , β_d , β_{hs} , β_{ec} and β_{ed} defined in TS 125 214 [8].

Table 4.2.12.2-1: UE ACLR

Power Class	Adjacent channel frequency relative to assigned channel frequency	ACLR limit
3	+5 MHz or -5 MHz	32,2 dB
3	+10 MHz or -10 MHz	42,2 dB
4	+5 MHz or -5 MHz	32,2 dB
4	+10 MHz or -10 MHz	42,2 dB

NOTE 1: The requirement shall still be met in the presence of switching transients.
 NOTE 2: The ACLR requirements reflect what can be achieved with present state of the art technology.
 NOTE 3: Requirement on the UE shall be reconsidered when the state of the art technology progresses.

TEST PROCEDURE

- 1) The SS sends continuously Up power control commands to the UE until the UE transmitter power reaches maximum level.
- 2) Measure the RRC filtered mean power.
- 3) Measure the RRC filtered mean power of the first adjacent channels and the second adjacent channels.
- 4) Calculate the ratio of the power between the values measured in 2) and 3) above.

TEST RESULTS

MAIN MODEM

Mode	Test Frequency (MHz)	Test Condition					Result
Band I	1922.6	Normal	L.V. L.T.	L.V. H.T.	H.V L.T	H.V. H.T	Compliance
	1950.0	Normal	L.V. L.T.	L.V. H.T.	H.V L.T	H.V. H.T	Compliance
	1977.4	Normal	L.V. L.T.	L.V. H.T.	H.V L.T	H.V. H.T	Compliance
Band VIII	882.6	Normal	L.V. L.T.	L.V. H.T.	H.V L.T	H.V. H.T	Compliance
	897.6	Normal	L.V. L.T.	L.V. H.T.	H.V L.T	H.V. H.T	Compliance
	912.4	Normal	L.V. L.T.	L.V. H.T.	H.V L.T	H.V. H.T	Compliance

Note: For test data, please refer to the AIT23071306CW7-WCDMA Test Data

4.7. RECEIVER SPURIOUS EMISSIONS

TEST LIMIT

The power of any narrow band CW spurious emission shall not exceed the maximum level specified in tables 4.2.10.2-1 and 4.2.10.2-2.

Table 4.2.10.2-1: General receiver spurious emission requirements

Frequency band	Measurement bandwidth	Maximum level
$30 \text{ MHz} \leq f < 1 \text{ GHz}$	100 kHz	-57 dBm
$1 \text{ GHz} \leq f \leq 12,75 \text{ GHz}$	1 MHz	-47 dBm

Table 4.2.10.2-2: Additional receiver spurious emission requirements

Band	Frequency Range	Measurement Bandwidth	Maximum level
I	$1\,920 \text{ MHz} \leq f \leq 1\,980 \text{ MHz}$	3,84 MHz	-60 dBm
III	$1\,710 \text{ MHz} \leq f \leq 1\,785 \text{ MHz}$	3,84 MHz	-60 dBm
VII	$2\,500 \text{ MHz} \leq f \leq 2\,570 \text{ MHz}$	3,84 MHz	-60 dBm
VIII	$880 \text{ MHz} \leq f \leq 915 \text{ MHz}$	3,84 MHz	-60 dBm
XV	$791 \text{ MHz} \leq f < 821 \text{ MHz}$	3,84 MHz	-60 dBm
	$921 \text{ MHz} \leq f < 925 \text{ MHz}$	100 kHz	-60 dBm (see note)
	$925 \text{ MHz} \leq f < 935 \text{ MHz}$	100 kHz	-67 dBm (see note)
		3,84 MHz	-60 dBm
	$935 \text{ MHz} \leq f \leq 960 \text{ MHz}$	100 kHz	-79 dBm (see note)
	$1\,805 \text{ MHz} \leq f \leq 1\,880 \text{ MHz}$	100 kHz	-71 dBm (see note)
	$1\,900 \text{ MHz} \leq f \leq 1\,920 \text{ MHz}$	3,84 MHz	-60 dBm
	$2\,110 \text{ MHz} \leq f \leq 2\,170 \text{ MHz}$	3,84 MHz	-60 dBm
	$2\,585 \text{ MHz} \leq f \leq 2\,690 \text{ MHz}$	3,84 MHz	-60 dBm

Band	Frequency Range	Measurement Bandwidth	Maximum level
XVI	$791 \text{ MHz} \leq f < 821 \text{ MHz}$	3,84 MHz	-60 dBm
	$921 \text{ MHz} \leq f < 925 \text{ MHz}$	100 kHz	-60 dBm (see note)
	$925 \text{ MHz} \leq f < 935 \text{ MHz}$	100 kHz	-67 dBm (see note)
		3,84 MHz	-60 dBm
	$935 \text{ MHz} \leq f \leq 960 \text{ MHz}$	100 kHz	-79 dBm (see note)
	$1\,805 \text{ MHz} \leq f \leq 1\,880 \text{ MHz}$	100 kHz	-71 dBm (see note)
	$2\,010 \text{ MHz} \leq f \leq 2\,025 \text{ MHz}$	3,84 MHz	-60 dBm
	$2\,110 \text{ MHz} \leq f \leq 2\,170 \text{ MHz}$	3,84 MHz	-60 dBm
	$2\,585 \text{ MHz} \leq f \leq 2\,690 \text{ MHz}$	3,84 MHz	-60 dBm
XX	$832 \text{ MHz} \leq f \leq 862 \text{ MHz}$	3,84 MHz	-60 dBm
XXII	$3\,410 \text{ MHz} \leq f \leq 3\,490 \text{ MHz}$	3,84 MHz	-60 dBm

NOTE: The receiver additional spurious emission measurements are made on frequencies which are integer multiples of 200 kHz. As exceptions, up to five measurements with a level up to the applicable requirements defined in table 4.2.10.2-1 are permitted for each UARFCN used in the measurement. This note applies also to receiver additional spurious emission measurements according to table 4.2.12.1.2-1.

TEST PROCEDURE

Sweep the spectrum analyser (or other suitable test equipment) over a frequency range from 30 MHz to 12.75 GHz and measure the average power of the spurious emissions.

TEST RESULTS

MAIN MODEM

Mode	Test Frequency (MHz)	Test Condition					Result
Band I	1922.6	Normal	L.V. L.T.	L.V. H.T.	H.V L.T	H.V. H.T	Compliance
	1950.0	Normal	L.V. L.T.	L.V. H.T.	H.V L.T	H.V. H.T	Compliance
	1977.4	Normal	L.V. L.T.	L.V. H.T.	H.V L.T	H.V. H.T	Compliance
Band VIII	882.6	Normal	L.V. L.T.	L.V. H.T.	H.V L.T	H.V. H.T	Compliance
	897.6	Normal	L.V. L.T.	L.V. H.T.	H.V L.T	H.V. H.T	Compliance
	912.4	Normal	L.V. L.T.	L.V. H.T.	H.V L.T	H.V. H.T	Compliance

Note: For test data, please refer to the AIT23071306CW7-WCDMA Test Data

4.8. RECEIVER ADJACENT CHANNEL SELECTIVITY (ACS)

TEST LIMIT

For the UE of power class 3 and 4, the BER shall not exceed 0,001 for the parameters specified in table 4.2.6.2-1. This test condition is equivalent to the ACS value 33 dB.

Table 4.2.6.2-1: Test parameters for adjacent channel selectivity

Parameter	Unit	Case 1	Case 2
DPCH _{Ec}	dBm/3,84 MHz	<REFSENS> + 14 dB	<REFSENS> + 41 dB
I _{or}	dBm/3,84 MHz	<REFI _{or} > + 14 dB	<REFI _{or} > + 41 dB
I _{oac} mean power (modulated)	dBm	-52	-25
F _{uw} (offset)	MHz	+5 or -5	+5 or -5
UE transmitted mean power	dBm	20 (for Power class 3) 18 (for Power class 4)	20 (for Power class 3) 18 (for Power class 4)
NOTE 1: <REFSENS> and <REFI _{or} > as specified in TS 134 121-1 [2].			
NOTE 2: The I _{oac} (modulated) signal consists of the common channels and the 16 dedicated data channels as specified in TS 125 101 [5].			

TEST PROCEDURE

- 1) Set the parameters of the interference signal generator as shown in table 4.2.6.2-1 case 1.
- 2) Set the power level of UE according to the table 4.2.6.2-1 case 1 with ±1 dB tolerance.
- 3) Measure the BER of DCH received from the UE at the SS.
- 4) Set the parameters of the interference signal generator as shown in table 4.2.6.2-1 case 2.
- 5) Set the power level of UE according to the table 4.2.6.2-1 case 2 with ±1 dB tolerance.
- 6) Measure the BER of DCH received from the UE at the SS.

TEST RESULTS

Note: For test data, please refer to the AIT23071306CW7-WCDMA Test Data

4.9. RECEIVER BLOCKING CHARACTERISTICS

TEST LIMIT

The BER shall not exceed 0,001 for the parameters specified in tables 4.2.7.2-1 and 4.2.7.2-2. For table 4.2.7.2-2 up to 24 exceptions are allowed for spurious response frequencies in each assigned frequency channel when measured using a 1 MHz step size.

Table 4.2.7.2-1: Test parameters for in-band blocking characteristics

Parameter	Unit	Level	
DPCH_Ec	dBm/3,84 MHz	<REFSENS> + 3 dB	
I _{or}	dBm/3,84 MHz	<REFI _{or} > + 3 dB	
I _{blocking} mean power (modulated)	dBm	-56 (for F _{uw} offset ±10 MHz)	-44 (for F _{uw} offset ±15 MHz)
F _{uw} (Band I operation)	MHz	2 102,4 ≤ f ≤ 2 177,6	2 095 ≤ f ≤ 2 185
F _{uw} (Band III operation)	MHz	1 797,4 ≤ f ≤ 1 887,6	1 790 ≤ f ≤ 1 895
F _{uw} (Band VII operation)	MHz	2 612,4 ≤ f ≤ 2 697,6	2 605 ≤ f ≤ 2 705
F _{uw} (Band VIII operation)	MHz	917,4 ≤ f ≤ 967,6	910 ≤ f ≤ 975
F _{uw} (Band XX operation)	MHz	783,4 ≤ f ≤ 828,6	776 ≤ f ≤ 836
F _{uw} (Band XXII operation)	MHz	3 502,4 ≤ f ≤ 3 597,6	3 495 ≤ f ≤ 3 605
UE transmitted mean power	dBm	20 (for Power class 3) 18 (for Power class 4) (note 3)	
NOTE 1: <REFSENS> and <REFI _{or} > as specified in ETSI TS 134 121-1 [1].			
NOTE 2: The I _{blocking} (modulated) signal consists of the common channels and the 16 dedicated data channels as specified in ETSI TS 125 101 [4].			
NOTE 3: The UE transmitted mean power shall be reduced by 0,5 dB for a UE operating in band XXII.			

Table 4.2.7.2-2: Test parameters for out-of-band blocking characteristics

Parameter	Unit	Frequency range 1	Frequency range 2	Frequency range 3
DPCH_Ec	dBm/3,84 MHz	<REFSENS> + 3 dB	<REFSENS> + 3 dB	<REFSENS> + 3 dB
I_{or}	dBm/3,84 MHz	<REF I_{or} > + 3 dB	<REF I_{or} > + 3 dB	<REF I_{or} > + 3 dB
$I_{blocking}$ (CW)	dBm	-44	-30	-15
F_{uw} (Band I operation)	MHz	2 050 < f < 2 095 2 185 < f < 2 230	2 025 < f ≤ 2 050 2 230 ≤ f < 2 255	1 < f ≤ 2 025 2 255 ≤ f < 12 750
F_{uw} (Band III operation)	MHz	1 745 < f < 1 790 1 895 < f < 1 940	1 720 < f ≤ 1 745 1 940 ≤ f < 1 965	1 < f ≤ 1 720 1 965 ≤ f < 12 750
F_{uw} (Band VII operation)	MHz	2 570 < f < 2 605 2 705 < f < 2 750	Na 2 750 ≤ f < 2 775	1 < f ≤ 2 570 2 775 ≤ f < 12 750
F_{uw} (Band VIII operation)	MHz	865 < f < 910 975 < f < 1 020	840 < f < 865 1 020 ≤ f < 1 045	1 < f ≤ 840 1 045 ≤ f < 12 750
F_{uw} (Band XV operation)	MHz	2 570 < f < 2 585 2 705 < f < 2 750	Na 2 750 ≤ f < 2 775	1 < f ≤ 2 570 2 775 ≤ f < 12 750
F_{uw} (Band XVI operation)	MHz	Na 2 705 < f < 2 750	2 500 < f ≤ 2 570 2 750 ≤ f < 2 775	1 < f ≤ 2 500 2 775 ≤ f < 12 750
F_{uw} (Band XX operation)	MHz	731 < f < 776 836 < f < 881	706 < f ≤ 731 881 ≤ f < 906	1 < f ≤ 706 906 ≤ f < 12 750
F_{uw} (Band XXII operation)	MHz	3 450 < f < 3 495 3 605 < f < 3 650	3 425 < f ≤ 3 450 3 650 ≤ f < 3 675	1 < f ≤ 3 425 3 675 ≤ f < 12 750
UE transmitted mean power	dBm	20 (for Power class 3) 18 (for Power class 4)		
Band I operation	For 2 095 MHz ≤ f ≤ 2 185 MHz, the appropriate in-band blocking or adjacent channel selectivity in clause 4.2.6 and table 4.2.7.2-1 shall be applied.			
Band III operation	For 1 790 MHz ≤ f ≤ 1 895 MHz, the appropriate in-band blocking or adjacent channel selectivity in clause 4.2.6 and table 4.2.7.2-1 shall be applied.			

Parameter	Unit	Frequency range 1	Frequency range 2	Frequency range 3
Band III operation	For 1 790 MHz ≤ f ≤ 1 895 MHz, the appropriate in-band blocking or adjacent channel selectivity in clause 4.2.6 and table 4.2.7.2-1 shall be applied.			
Band VII operation	For 2 605 MHz ≤ f ≤ 2 705 MHz, the appropriate in-band blocking or adjacent channel selectivity in clause 4.2.6 and table 4.2.7.2-1 shall be applied.			
Band VIII operation	For 910 MHz ≤ f ≤ 975 MHz, the appropriate in-band blocking or adjacent channel selectivity in clause 4.2.6 and table 4.2.7.2-1 shall be applied.			
Band XV operation	For 2 585 MHz ≤ f ≤ 2 705 MHz, the appropriate in-band blocking or adjacent channel selectivity in clause 4.2.6 and table 4.2.7.2-1 shall be applied.			
Band XVI operation	For 2 570 MHz ≤ f ≤ 2 705 MHz, the appropriate in-band blocking or adjacent channel selectivity in clause 4.2.6 and table 4.2.7.2-1 shall be applied.			
Band XX operation	For 776 MHz ≤ f ≤ 836 MHz, the appropriate in-band blocking or adjacent channel selectivity in clause 4.2.6 and table 4.2.7.2-1 shall be applied.			
Band XXII operation	For 3 495 ≤ f ≤ 3 605 MHz, the appropriate in-band blocking or adjacent channel selectivity in clause 4.2.6 and clause 4.2.7.2-1 shall be applied. (note 2)			
NOTE 1: <REFSENS> and <REF I_{or} > as specified in ETSI TS 134 121-1 [1].				
NOTE 2: The UE transmitted mean power shall be reduced by 0,5 dB for a UE operating in band XXII.				

TEST PROCEDURE

- 1) Set the parameters of the CW generator or the interference signal generator as shown in tables 4.2.7.2-1, 4.2.7.2-2 and 4.2.7.2-3. For table 4.2.7.2-2 the frequency step size is 1 MHz.
- 2) Set the power level of the UE according to tables 4.2.7.2-1, 4.2.7.2-2 and 4.2.7.2-3 with a ± 1 dB tolerance.
- 3) Measure the BER of DCH received from the UE at the SS.
- 4) For table 4.2.7.2-2, record the frequencies for which the BER exceeds the test requirements.

TEST RESULTS

Note: For test data, please refer to the AIT23071306CW7-WCDMA Test Data

4.10. RECEIVER SPURIOUS RESPONSE

TEST LIMIT

The BER shall not exceed 0,001 for the parameters specified in table 4.2.8.2-1.

Table 4.2.8.2-1: Test parameters for spurious response

Parameter	Level	Unit
DPCH_Ec	<REFSENS> + 3 dB	dBm/3,84 MHz
I _{or}	<REFI _{or} > + 3 dB	dBm/3,84 MHz
I _{blocking} (CW)	-44	dBm
F _{uw}	Spurious response frequencies	MHz
UE transmitted mean power	20 (for Power class 3) 18 (for Power class 4) (note 2)	dBm
NOTE 1: <REFSENS> and <REFI _{or} > as specified in ETSI TS 134 121-1 [1].		
NOTE 2: The UE transmitted mean power shall be reduced by 0,5 dB, for a UE operating in band XXII.		

TEST PROCEDURE

- 1) Set the parameter of the CW generator as shown in table 4.2.8.2-1. The spurious response frequencies are determined in step 4) of clause 5.3.6.1.2.
- 2) Set the power level of the UE according to table 4.2.8.2-1 with a ±1 dB tolerance.
- 3) Measure the BER of DCH received from the UE at the SS.

TEST RESULTS

Note: For test data, please refer to the AIT23071306CW7-WCDMA Test Data

4.11. RECEIVER INTERMODULATION CHARACTERISTICS

TEST LIMIT

The BER shall not exceed 0,001 for the parameters specified in table 4.2.9.2-1.

Table 4.2.9.2-1: Receive intermodulation characteristics

Parameter	Level		Unit
DPCH_Ec	<REFSENS> + 3 dB		dBm/3,84 MHz
\hat{I}_{or}	<REF \hat{I}_{or} > + 3 dB		dBm/3,84 MHz
I_{ouw1} (CW)	-46		dBm
I_{ouw2} mean power (modulated)	-46		dBm
F_{uw1} (offset)	10	-10	MHz
F_{uw2} (offset)	20	-20	MHz
UE transmitted mean power	20 (for Power class 3) 18 (for Power class 4) (note 3)		dBm
NOTE 1: I_{ouw2} (modulated) consists of the common channels and the 16 dedicated data channels as specified in TS 125 101 [5].			
NOTE 2: <REFSENS> and <REF \hat{I}_{or} > as specified in TS 134 121-1 [2].			
NOTE 3: The UE transmitted mean power shall be reduced by 0,5 dB for a UE operating in band XXII.			

Table 4.2.9.2-2: Test parameters for narrow band intermodulation characteristics

Parameter	Unit	Band III, VIII	
DPCH_Ec	dBm/3,84 MHz	<REFSENS> + 10 dB	
\hat{I}_{or}	dBm/3,84 MHz	<REF \hat{I}_{or} > + 10 dB	
I_{ouw1} (CW)	dBm	-43	
I_{ouw2} (GMSK)	dBm	-43	
F_{uw1} (offset)	MHz	3,6	-3,6
F_{uw2} (offset)	MHz	6,0	-6,0
UE transmitted mean power	dBm	20 (for Power class 3) 18 (for Power class 4)	
NOTE 1: <REFSENS> and <REF \hat{I}_{or} > as specified in TS 134 121-1 [2].			
NOTE 2: I_{ouw2} (GMSK) is an interfering signal as defined in TS 145 004 [9]. It is a continuous GMSK modulated carrier following the structure of the GSM signals, but with all modulating bits (including the midamble period) derived directly from a random or any pseudo random data stream.			

TEST PROCEDURE

- 1) Set the parameters of the CW generator and interference generator as shown in tables 4.2.9.2-1 and 4.2.9.2-2.
- 2) Set the power level of the UE according to tables 4.2.9.2-1 and 4.2.9.2-2 with a ± 1 dB tolerance.
- 3) Measure the BER of DCH received from the UE at the SS.

TEST RESULTS

Note: For test data, please refer to the AIT23071306CW7-WCDMA Test Data

4.12. OUT-OF-SYNCHRONIZATION HANDLING OF OUTPUT POWER

TEST LIMIT

When the UE estimates the DPCCH quality over the last 160 ms period to be worse than a threshold Q_{out} , the UE shall shut its transmitter off within 40 ms.

The quality level at the thresholds Q_{out} correspond to different signal levels depending on the downlink conditions DCH parameters. For the conditions in table 4.2.11.2-1, a signal with the quality at the level Q_{out} can be generated by a $DPCCH_Ec/I_{or}$ ratio of -25 dB. The DL reference measurement channel 12,2 kbit/s is specified in TS 134 121-1 [2] and with static propagation conditions. The downlink physical channels, other than those specified in table 4.2.11.2-1, are as specified in TS 134 121-1 [2].

Table 4.2.11.2-1: DCH parameters for test of out-of-synchronization handling

Parameter	Value	Unit
I_{or}/I_{oc}	-1	dB
I_{oc}	-60	dBm/3,84 MHz
$\frac{DPDCH_Ec}{I_{or}}$	See figure 4.2.11.2-1: Before point A: <ul style="list-style-type: none"> -16,6 for UEs not supporting enhanced receiver performance type 1 for DCH -19,6 for UEs supporting enhanced receiver performance type 1 for DCH After point A not defined	dB
$\frac{DPCCH_Ec}{I_{or}}$	See figure 4.2.11.2-1	dB
Information Data Rate	12,2	kbit/s

Figure 4.2.11.2-1 and table 4.2.11.2-2 show an example scenario where the $DPCCH_Ec/I_{or}$ ratio varies from a level where the DPCH is demodulated under normal conditions, down to a level below Q_{out} where the UE shall shut its power off.

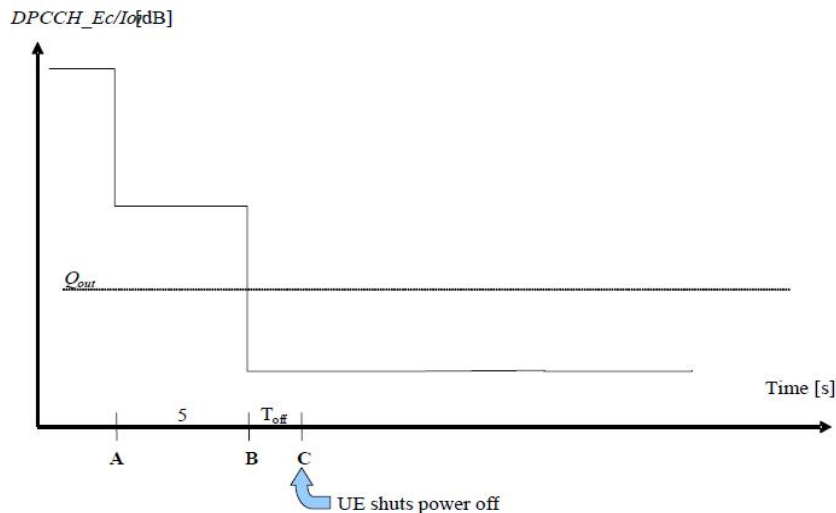

Figure 4.2.11.2-1: Conditions for out-of-synchronization handling in the UE

Table 4.2.11.2-2: Conditions for out-of-synchronization handling in the UE

Clause from figure 4.2.11.2-1	DPCCH_Ec/Ior (UE, not supporting enhanced performance requirements type 1 for DCH)	DPCCH_Ec/Ior (UE, supporting enhanced performance requirements type 1 for DCH)	Unit
Before A	-16,6	-19,6	dB
A to B	-21,6	-24,6	dB
After B	-28,4	-31,4	dB

The requirements for the UE are that it shall shut its transmitter off before point C.

The UE transmitter is considered to be OFF if the measured RRC filtered mean power is less than -55 dBm.

TEST PROCEDURE

- 1) The SS sends continuously up power control commands to the UE until the UE transmitter power reach maximum level.
- 2) The SS controls the DPCCH_Ec/Ior ratio level according to table 4.2.11.2-2, 'A to B'.
- 3) The SS controls the DPCCH_Ec/Ior ratio level according to table 4.2.11.2-2, 'after B'. The SS waits 200ms and then verifies that the UE transmitter has been switched off.
- 4) The SS monitors the UE transmitted power for 5 s and verifies that the UE transmitter is not switched on during this time.

TEST RESULTS

Note: For test data, please refer to the AIT23071306CW7-WCDMA Test Data

4.13. RECEIVER REFERENCE SENSITIVITY LEVEL

TEST LIMIT

The measured BER shall not exceed 0,001.

Table 4.2.13.2-1: Test parameters for Reference Sensitivity Level

Operating Band	Unit	DPCH_Ec <REFSENS>	<REF _{or} >
I	dBm/3,84 MHz	-116,3	-106
III	dBm/3,84 MHz	-113,3	-103
VII	dBm/3,84 MHz	-114,3	-104
VIII	dBm/3,84 MHz	-113,3	-103
XX	dBm/3,84 MHz	-113,3	-103
XXII	dBm/3,84 MHz	-113,3	-103
NOTE 1: For Power class 3 and 3bis this shall be at the maximum output power.			
NOTE 2: For Power class 4 this shall be at the maximum output power.			

NOTE: These requirements do not take into account the allowed increase of the reference sensitivity level of DPCH_Ec and corresponding < REF_{or}>in ETSI TS 134 121-1 [1], table 6.2.2 by the amount defined in minimum requirement clause for the UE, which supports DB-DC-HSDPA or dual band 4C-HSDPA and/or E-UTRA inter-band carrier aggregation.

TEST PROCEDURE

The frequencies to be tested are low range, mid range, high range as defined in ETSI TS 134 108 [2], clause 5.1:

- 1) Connect the SS to the UE antenna connector.
- 2) A call is set up according to the Generic call setup procedure as per ETSI TS 134 108 [2], and RF parameters are set up according to table 4.2.13.2-1.
- 3) Enter the UE into loopback test mode and start the loopback test using the procedure defined in ETSI TS 134 109 [3], clause 5.3.

NOTE: When reference is made to test set up, call set up and loopback test mode, guidance on the applicability of these can be found in ETSI TS 134 121-1 [1], ETSI TS 134 108 [2] and ETSI TS 134 109 [3].

Details of initial conditions for UEs supporting UTRA FDD can be found in ETSI TS 134 121-1 [1], clause 6.2.

- 1) Set and send continuously Up power control commands to the UE until the UE output power shall be maximum level.
- 2) Measure the BER of DCH received from the UE at the SS.

Details of initial conditions for UEs supporting UTRA FDD can be found in ETSI TS 134 121-1 [1], clause 6.2.



TEST RESULTS

Note: For test data, please refer to the AIT23071306CW7-WCDMA Test Data

4.14. CONTROL AND MONITORING FUNCTIONS (UE)

TEST LIMIT

The maximum measured power during the duration of the test shall not exceed -30 dBm. Table 4.2.4.1.2-1: General spurious emissions requirements.

TEST PROCEDURE

- 1) At the start of the test, the UE shall be switched off. The UE antenna connector shall be connected to a power measuring equipment, with the following characteristics:
 - The RF bandwidth shall exceed the total operating transmit frequency range of the UE for operation with an applicable part.
 - The response time of the power measuring equipment shall be such that the measured power has reached within 1 dB of its steady state value within 100 μs of a CW signal being applied.
 - It shall record the maximum power measured.

NOTE: The equipment may include a video low pass filter to minimize its response to transients or Gaussian noise peaks.

- 2) The UE shall be switched on for a period of approximately fifteen minutes, and then switched off.
- 3) The EUT shall remain switched off for a period of at least thirty seconds, and shall then be switched on for a period of approximately one minute.
- 4) The maximum power emitted from the UE throughout the duration of the test shall be recorded. The results obtained shall be compared to the limits in clause 4.2.4.2 in order to prove compliance.

TEST RESULTS

TX Mode:

Test Case	Power-Real (Voltage)	Max Level (dBm)	Limit (dBm)	Margin (dBm)	Results
WCDMA Band I	DC 3.8V	-50.26	-30	-20.26	PASS
WCDMA Band VIII	DC 3.8V	-49.77	-30	-19.77	PASS

4.15. RADIATED EMISSIONS (UE)

TEST LIMIT

The frequency boundary and reference bandwidths for the detailed transitions of the limits between the requirements for out-of-band emissions and spurious emissions are based on Recommendations ITU-R SM.329-12 [1] and SM.1539-1 [i.6].

The requirements shown in table 4.2.2.2-1 are only applicable for frequencies in the spurious domain

Table 4.2.2.2-1: Radiated spurious emissions requirements (UE)

Frequency	Minimum requirement (e.r.p.)/ reference bandwidth idle mode	Minimum requirement (e.r.p.)/ reference bandwidth traffic mode	Applicability
$30 \text{ MHz} \leq f < 1\,000 \text{ MHz}$	-57 dBm/100 kHz	-36 dBm/100 kHz	All
$1 \text{ GHz} \leq f < 12,75 \text{ GHz}$	-47 dBm/1 MHz	-30 dBm/1 MHz	All
$12,75 \text{ GHz} \leq f < 5^{\text{th}}$ harmonic of the upper frequency edge of the Uplink operating band in GHz	-47 dBm/1 MHz	-30 dBm/1 MHz	All (note 3)
$12,75 \text{ GHz} < f < 26 \text{ GHz}$	-47 dBm/1 MHz	-30 dBm/1 MHz	All (note 4)
$f_c - 2,5 \times 5 \text{ MHz} < f < f_c + 2,5 \times 5 \text{ MHz}$ (note 1 and note 2)	Not defined	Not defined	UTRA FDD, UTRA TDD, 3,84 Mcps option, cdma2000, spreading rate 3
$f_c - 2,5 \times \text{BW}_{\text{Channel}} \text{ MHz} < f < f_c + 2,5 \times \text{BW}_{\text{Channel}} \text{ MHz}$ (note 1 and note 2)	Not defined	Not defined	E-UTRA FDD, E-UTRA TDD, Mobile WiMAX™
$f_c - (1,5 \times \text{BW}_{\text{Channel}} + 5) \text{ MHz} < f < f_c + (1,5 \times \text{BW}_{\text{Channel}} + 5) \text{ MHz}$ (note 1)	Not defined	Not defined	NR operating in FR1
$f_c - 2,5 \times 10 \text{ MHz} < f < f_c + 2,5 \times 10 \text{ MHz}$ (note 1 and note 2)	Not defined	Not defined	UTRA TDD, 7,68 Mcps option
$f_c - 4 \text{ MHz} < f < f_c + 4 \text{ MHz}$ (note 1 and note 2)	Not defined	Not defined	UTRA TDD, 1,28 Mcps option cdma2000, spreading rate 1
NOTE 1: f_c is the UE transmit centre frequency.			
NOTE 2: This frequency range is not in the spurious domain, no requirement is then defined for this frequency range.			
NOTE 3: Applies for Band that the upper frequency edge of the Uplink Band more than 2,69 GHz.			
NOTE 4: Applies for Band that the upper frequency edge of the Uplink Band more than 5,2 GHz.			

TEST SETUP

Radiated Emission Test Set-Up Frequency 30 MHz ~ 1 GHz

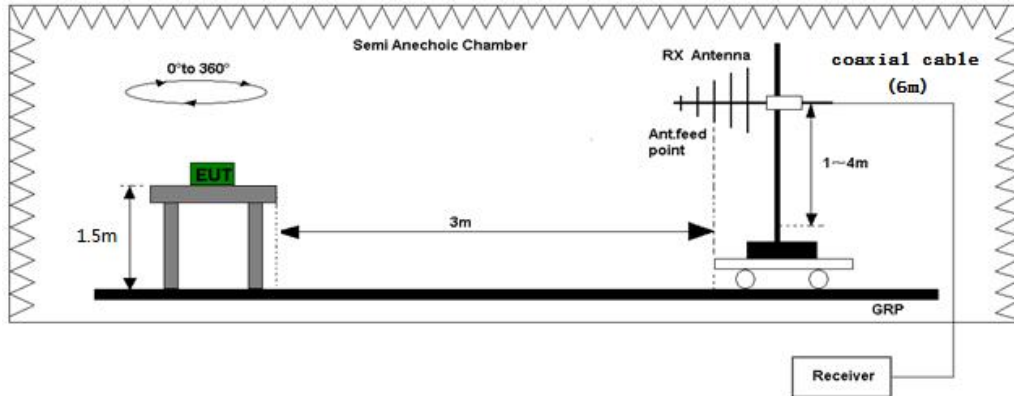

Radiated Emission Test Set-Up Frequency Above 1 GHz

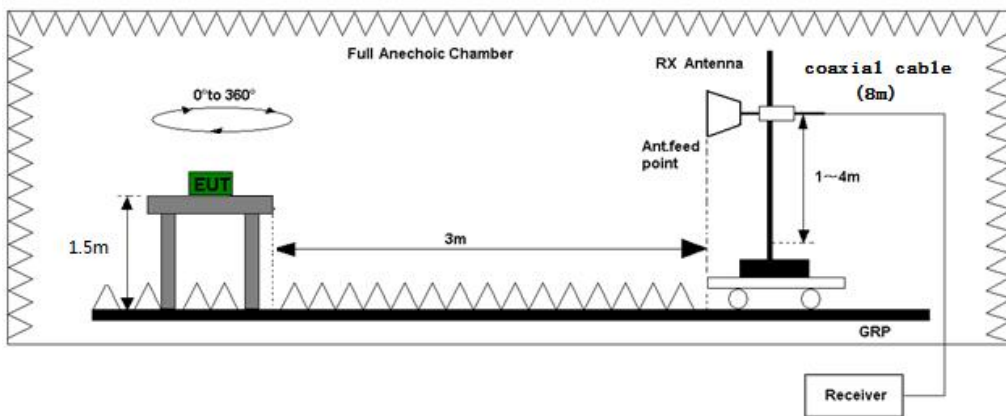

TEST PROCEDURE

Step 1:

The measurement is carried out in the fully anechoic chamber. EUT was placed on a 1.50 meter high nonconductive table at a 3 meter test distance from the test receive antenna. A receiving antenna was placed on the antenna mast 3 meters from the EUT. The height of receiving antenna is 1.50 m and varies in certain range to find the maximum power value. Connect the EUT to the BTS simulator via the air interface.

The measurement is carried out using a spectrum analyzer or receiver. Then the antenna height and turn table rotation is adjusted till the maximum power value is founded on spectrum analyzer or receiver.

A filter is necessary in the band near to the carrier frequency. A filter is needed to avoid the distortion of the testing equipment in the band above the carrier frequency.

Step 2:

A log-periodic antenna or double-ridged waveguide horn antenna shall be substituted in place of the EUT.

The log-periodic antenna will be driven by a signal generator and the level will be adjusted till the same power value on the spectrum analyzer or receiver. The level of the spurious emissions can be calculated through the level of the signal generator, cable loss, the gain of the substitution antenna and the reading of the spectrum analyzer or receiver.

Calculation procedure:

The data of cable loss, antenna gain and air loss has been calibrated in full testing frequency range before the testing.

The power of the Radiated Spurious Emissions is calculated by adding the cable loss, antenna gain and air loss.

The basic equation with a sample calculation is as followed:

$$P=PR+LC+LA-G$$

Where

P: Power of the Radiated Spurious Emissions (dBm)

PR: reading of the receiver (dBm)

LC: Cable Lose and power amilifer gain and filter cable loss (dB)

LA: Air loss (dB)

G: Antenna Gain (dBi)

TEST RESULTS

This test was carried out in all the test modes, and record worst case as blow.

The EUT has met the requirements of 3GPP2 C.S0011-A's requirement.

Remark: Normal and extreme voltage test conditions have been tested, only the measurement data of normal voltage condition are reported.

WCDMA Band VIII				
Test mode:		Traffic mode	Test condition:	
Channel:		Middle	Polarity:	
Suspected List				
NO.	Freq. [MHz]	Result Level [dBm]	Limit (dBm)	Margin (dB)
1	1795.20	-37.59	-30.00	7.59
2	2692.80	-40.24	-30.00	10.24
3	3590.40	-40.39	-30.00	10.39
4	4488.00	-43.59	-30.00	13.59
--	--	--	--	--
Test mode:		Traffic mode	Test condition:	
Channel:		Middle	Polarity:	
Suspected List				
NO.	Freq. [MHz]	Result Level [dBm]	Limit (dBm)	Margin (dB)
1	1795.20	-36.23	-30.00	6.23
2	2692.80	-38.95	-30.00	8.95
3	3590.40	-39.23	-30.00	9.23
4	4488.00	-42.45	-30.00	12.45
--	--	--	--	--

WCDMA Band VIII				
Test mode:		Traffic mode	Test condition:	
Channel:		Middle	Polarity:	
Suspected List				
NO.	Freq. [MHz]	Result Level [dBm]	Limit (dBm)	Margin (dB)
1	795.20	-37.16	-30.00	7.16
2	992.80	-38.81	-30.00	8.81
3	3590.40	-40.30	-30.00	10.30
4	4488.00	-42.77	-30.00	12.77
--	--	--	--	--
Test mode:		Traffic mode	Test condition:	
Channel:		Middle	Polarity:	
Suspected List				
NO.	Freq. [MHz]	Result Level [dBm]	Limit (dBm)	Margin (dB)
1	795.20	-35.39	-30.00	5.39
2	992.80	-38.52	-30.00	8.52
3	3590.40	-39.57	-30.00	9.57
4	4488.00	-42.23	-30.00	12.23
--	--	--	--	--

RESULT: PASS

WCDMA Band I				
Test mode:		Idle mode	Test condition:	
Channel:		Middle	Polarity:	
			NTNV	
			Horizontal	
Suspected List				
NO.	Freq. [MHz]	Result Level [dBm]	Limit (dBm)	Margin (dB)
1	293.85	-72.31	-54.00	18.31
2	886.78	-69.14	-54.00	15.14
3	3753.70	-62.84	-47.00	15.84
4	7009.36	-63.09	-47.00	16.09
--	--	--	--	--
Test mode:		Idle mode	Test condition:	
Channel:		Middle	Polarity:	
			NTNV	
			Vertical	
Suspected List				
NO.	Freq. [MHz]	Result Level [dBm]	Limit (dBm)	Margin (dB)
1	229.40	-71.11	-54.00	17.11
2	819.27	-67.66	-54.00	13.66
3	4041.08	-61.46	-47.00	14.46
4	7298.78	-61.78	-47.00	14.78
--	--	--	--	--

WCDMA Band VIII				
Test mode:		Idle mode	Test condition:	
Channel:		Middle	Polarity:	
			NTNV	
			Horizontal	
Suspected List				
NO.	Freq. [MHz]	Result Level [dBm]	Limit (dBm)	Margin (dB)
1	184.32	-74.02	-54.00	20.02
2	846.63	-72.85	-54.00	18.85
3	2656.10	-65.00	-47.00	18.00
4	9809.29	-64.99	-47.00	17.99
--	--	--	--	--
Test mode:		Idle mode	Test condition:	
Channel:		Middle	Polarity:	
			NTNV	
			Vertical	
Suspected List				
NO.	Freq. [MHz]	Result Level [dBm]	Limit (dBm)	Margin (dB)
1	262.18	-72.91	-54.00	18.91
2	541.28	-71.77	-54.00	17.77
3	4462.65	-63.78	-47.00	16.78
4	4882.96	-63.64	-47.00	16.64
--	--	--	--	--

RESULT: PASS



Note:

1. Measurement Value = Reading Level + Correct Factor.
2. Margin Level = Measurement Value - Limit Value

4.16. Receiver Total Radiated Sensitivity (TRS)

APPLICABILITY

The present requirement applies to handheld phones/ DUT that are wider than or equal to 56 mm and narrower than or equal to 72 mm.

TEST RESULTS

Note:

The width of the prototype is 73mm, larger than 72mm, no test

4.17. Total Radiated Power (TRP)

APPLICABILITY

The present requirement applies to handheld phones/ DUT that are wider than or equal to 56 mm and narrower than or equal to 72 mm.

TEST RESULTS

Note:

The width of the prototype is 73mm, larger than 72mm, no test

5. APPENDIX I: PHOTOGRAPHS OF TEST SETUP

RADIATED EMISSION TEST SETUP

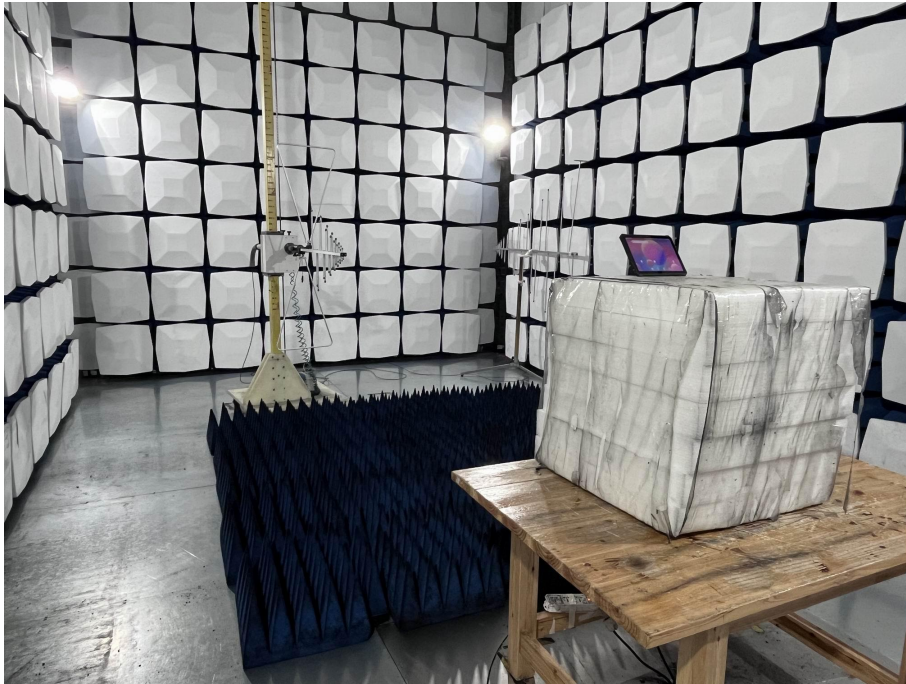

RADIATED EMISSION ABOVE 1G TEST SETUP

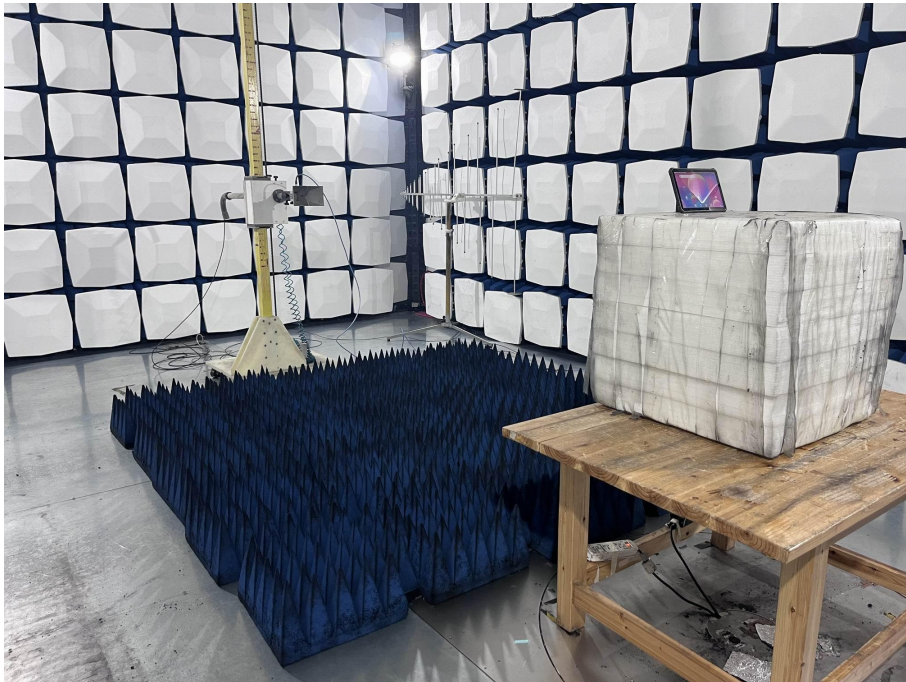

-----END OF REPORT-----