



RF TEST REPORT

For

2.0 Computer Multimedia Speaker

**Model Number: T-60X Pro, T-60X, T-65X, T-65X Pro, T-68X, T-68X Pro,
T-69X, T-69X Pro**

Report Number : WT228000037

Test Laboratory : Shenzhen Academy of Metrology and Quality
Inspection
Site Location : NETC Building, No.4 Tongfa Rd., Xili, Nanshan,
Shenzhen, China
Tel : 0086-755-86928965
Fax : 0086-755-86009898-31396
Web : www.smq.com.cn
E-mail : emcrf@smq.com.cn

重要声明

Important statement

1. 本院是深圳市人民政府依法设置的产品质量监督检验机构，系社会公益型非营利性技术机构，为各级政府执法部门进行监督管理提供技术支持和接受社会各界的委托检验。

SMQ is a legal non-profit technical institute established by Shenzhen Municipal Government to undertake the quality supervision and inspection of products, and to provide technical support to relevant supervision and administration and also conduct commission test from the society.

2. 本院保证检验的科学性、公正性和准确性，对检验的数据负责，并对委托单位所提供的样品和技术资料保密。

SMQ is committed to assuring the scientificness, impartiality and accuracy of all tests carried out, responsibility for test data gained, and keeping confidential of all test samples and technical documents provided.

3. 抽样按照本院程序文件《抽样程序》和相应产品的检验细则的规定执行。

The sampling should be carried out according to the "sampling procedure" defined in the Procedure Document and relevant testing specifications.

4. 报告/证书无主检、审核、批准人签字，或涂改，或未盖本院报告/证书专用章及骑缝章无效。未经本院许可，不得部分复印、摘用或篡改本报告/证书内容。复印证书/报告未重新加盖本院证书/报告专用章无效。

Any report/certificate having not been signed by relevant responsible engineer, reviewer or authorized approver, or having been altered without authorization, or without both the Dedicated Report/Certificate Seal and its across-page seal is deemed to be invalid. Copying or excerpting portion of, or altering the content of the report/certificate is not permitted without the written authorization of SMQ. Any copy of certificates/reports without the Dedicated Report/Certificate Seal is deemed to be invalid.

5. 送样委托检验结果仅对来样有效：委托检验的样品信息及委托方信息均由委托方提供，本院不对其真实性及准确性负责。

The test results presented in the report apply only to the tested sample. The product information and the applicant information are provided by the customer and SMQ assumes no responsibility for their validity and accuracy.

6. 未经检验机构同意，样品委托人不得擅自使用检验结果进行不当宣传。

Any use of SMQ test result for advertisement of the tested material or product must be approved in writing by SMQ.

7. 无 CMA 标志的报告/证书，仅作为科研、教学或内部质量控制之用。含粤字编号的 CAL 标志仅适用于产品标准和判定标准。

The non-CMA report/certificate issued by SMQ is only permitted to be used for research, teaching or internal quality control. CAL logo with symbol "Yue" is only relevant to product standards and reference of standards.

8. 委托方对报告/证书有异议的，应于报告发出之日起十五日内向本院提出。政府行政管理部门下达的监督检查任务，受检方对报告/证书有异议的，应按政府行政管理部门文件规定及国家相关法律、法规进行。

Any objection to report/certificate issued by SMQ should be submitted to SMQ within 15 days after the issuance of the test. The mandatory inspection assigned by government administrative departments shall be carried out in accordance with the documents and regulations of the government administrative department and relevant national laws and regulations if inspected parties raise any objection to the inspection.

9. 报告/证书更改后，发出的电子版报告/证书、报告/证书的扫描件及传真件将不被追回，委托方有义务将更改后的报告/证书提供给使用原报告/证书的相关方。

SMQ is not responsible for recalling the electronic version of the original report/certificate when any revision is made to them. The applicant assumes the responsibility of providing the revised version to any interested party who uses them.

10. 只申领电子报告时，相关内容和效力以电子报告为准；电子报告和纸质报告同时申领时，电子报告仅作为纸质报告的副本，相关内容和效力以同编号纸质报告为准。

The relevant content and effectiveness is subject to the electronic version of the original report which was only applied for. When an electronic report and a paper report are applied for at the same time, the electronic report is only a copy of the paper report, and the relevant content and effectiveness is subject to the paper report.

投诉及报告/证书真伪查询电话

Complaint hotline : 400-900-8999 按 5

Email : complaint@smq.com.cn



Test report declaration

Applicant : SHENZHEN FENDA TECHNOLOGY CO.,LTD
Address : Fenda Hi-Tech Park, Zhoushi Road, Shiyan Street, Baoan District, Shenzhen, China
Manufacturer : SHENZHEN FENDA TECHNOLOGY CO.,LTD
Address : Fenda Hi-Tech Park, Zhoushi Road, Shiyan Street, Baoan District, Shenzhen, China
EUT Description : 2.0 Computer Multimedia Speaker
Model No. : T-60X Pro, T-60X, T-65X, T-65X Pro, T-68X, T-68X Pro, T-69X, T-69X Pro
Trade mark : F&D

Test Standards:

EN 300 328 V2.2.2 (2019-07)

The EUT described above is tested by Shenzhen Academy of Metrology and Quality Inspection EMC Laboratory to determine the maximum emissions from the EUT and ensure the EUT to be compliance with the immunity requirements of the EUT. Shenzhen Academy of Metrology and Quality Inspection EMC Laboratory is assumed full responsibility for the accuracy of the test results.

The test report is valid for above tested sample only and shall not be reproduced in part without written approval of the laboratory.

Project
Engineer:

(Zeng Wei 曾伟)

Date: Feb.25, 2022

Checked by:

(Shi changda 施昌达)

Date: Feb.25, 2022

Approved by:

(Lin yixiang 林奕翔)

Date: Feb.25, 2022



TABLE OF CONTENTS

TEST REPORT DECLARATION	2
1. TEST RESULTS SUMMARY	6
2. GENERAL INFORMATION.....	7
2.1. Report information.....	7
2.2. Laboratory Accreditation and Relationship to Customer	7
2.3. Measurement Uncertainty.....	8
3. PRODUCT DESCRIPTION.....	9
3.1. EUT Description.....	9
3.2. Block Diagram of EUT Configuration	9
3.3. Test System Configuration.....	10
3.4. Operating Condition of EUT	10
3.5. Support Equipment List	10
3.6. Test Conditions.....	11
3.7. Test Settings	11
3.8. Modifications	11
4. TEST EQUIPMENT USED	12
5. RF OUTPUT POWER.....	13
5.1. Test Requirements.....	13
5.2. Test Procedure	13
5.3. Test Data	13
6. POWER SPECTRAL DENSITY	14
6.1. Test Requirements.....	14
6.2. Test Procedure	14
6.3. Test Data	14
7. ACCUMULATED TRANSMIT TIME, FREQUENCY OCCUPATION &HOPPING SEQUENCE	15
7.1. Test Requirements.....	15
7.2. Test Procedure	16
7.3. Test Data	17



8.	HOPPING FREQUENCY SEPARATION	18
8.1.	Test Requirements	18
8.2.	Test Procedure	19
8.3.	Test Data	19
9.	ADAPTIVITY	20
9.1.	Test Requirements	20
9.2.	Test Procedure	23
9.3.	Test Data	23
10.	OCCUPIED CHANNEL BANDWIDTH	24
10.1.	Test Requirements	24
10.2.	Test Procedure	24
10.3.	Test Data	24
11.	TRANSMITTER UNWANTED EMISSIONS IN THE OUT-OF-BAND DOMAIN.....	25
11.1.	Test Requirements	25
11.2.	Test Procedure	25
11.3.	Test Data	25
12.	SPURIOUS EMISSIONS.....	26
12.1.	Test Requirements	26
12.2.	Test Procedure	26
12.3.	Test Data	26
13.	RECEIVER BLOCKING.....	27
13.1.	Test Requirements	27
13.2.	Test Procedure	29
13.3.	Test Data	29
ANNEX A TEST DATA(CONDUCTED TEST DATA)	30	
Appendix A: RF Output Power	30	
Appendix C: Accumulated Transmit Time, Frequency Occupation and Hopping Sequence.....	31	
Appendix D: Hopping Frequency Separation	32	
Appendix E: Occupied Channel Bandwidth	33	
Appendix F: Transmitter Unwanted Emissions In The Out-Of-Band Domain	34	
Appendix G: Transmitter unwanted emissions in the spurious domain.....	37	
Appendix H: Receiver spurious emissions	39	
Appendix I: Receiver Blocking	41	
Appendix B: Receiver spurious emissions.....	45	



ANNEX C TEST SETUP PHOTOS.....49

1. TEST RESULTS SUMMARY

Table 1 Test Results Summary

Test Items	Test Results
RF Output Power	Pass
Power Spectral Density	N/A
Accumulated Transmit Time, Frequency Occupation & Hopping Sequence	Pass
Hopping Frequency Separation	Pass
Duty cycle, Tx-Sequence, Tx-gap	N/A ¹
Medium Utilisation (MU) factor	N/A ¹
Adaptivity	N/A
Occupied Channel Bandwidth	Pass
Transmitter unwanted emissions in the out-of-band domain	Pass
Spurious emissions	Pass
Receiver Blocking	Pass
Geo-location capability	N/A ²

Remark: "N/A" means "Not applicable."

1. The manufacturer declared that the EUT can operate in adaptive mode only and non-adaptive mode is not supported.
2. The EUT does NOT support Geo-location capability.

Table 2 Maximum output power(EIRP)

Mode	Operating frequency range	Max EIRP (dBm)
Bluetooth	2402-2480 MHz	3.40



2. GENERAL INFORMATION

2.1. Report information

This report is not a certificate of quality; it only applies to the sample of the specific product/equipment given at the time of its testing. The results are not used to indicate or imply that they are application to the similar items. In addition, such results must not be used to indicate or imply that SMQ approves recommends or endorses the manufacture, supplier or use of such product/equipment, or that SMQ in any way guarantees the later performance of the product/equipment.

The sample/s mentioned in this report is/are supplied by Applicant, SMQ therefore assumes no responsibility for the accuracy of information on the brand name, model number, origin of manufacture or any information supplied.

Additional copies of the report are available to the Applicant at an additional fee. No third part can obtain a copy of this report through SMQ, unless the applicant has authorized SMQ in writing to do so.

2.2. Laboratory Accreditation and Relationship to Customer

The testing report were performed by the Shenzhen Academy of Metrology and quality Inspection EMC Laboratory (Guangdong EMC compliance testing center), in their facilities located at NETC Building, No.4 Tongfa Rd., Xili, Nanshan, Shenzhen, China. At the time of testing, Laboratory is accredited by the following organizations:

China National Accreditation Service for Conformity Assessment (CNAS) accredits the Laboratory for conformance to FCC standards, EMC international standards and EN standards. The Registration Number is CNAS L0579.

The Laboratory is Accredited Testing Laboratory of FCC with Designation number CN1165 and Site registration number 582918.

The Laboratory is registered to perform emission tests with Innovation, Science and Economic Development (ISED), and the registration number is 11177A.

The Laboratory is registered to perform emission tests with VCCI, and the registration number are C-20048, G20076, R-20077, R-20078, and T-20047.



The Laboratory is Accredited Testing Laboratory of American Association for Laboratory Accreditation (A2LA) and certificate number is 3292.01.

2.3. Measurement Uncertainty

Table 3 Measurement Uncertainty

Test Items	Measurement Uncertainty
RF Output Power	0.349 dB
Power timing	< 500ns
Power Spectral Density	0.372 dB
Occupied Channel Bandwidth	0.224 MHz
Transmitter unwanted emissions, conducted	1.39 dB
Radiated spurious emissions	±5.5 dB
Temperature	±0.698°C

3. PRODUCT DESCRIPTION

NOTE: The extreme test conditions for temperature and antenna gain were declared by the manufacturer.

3.1. EUT Description

Description	: 2.0 Computer Multimedia Speaker
Manufacturer	: SHENZHEN FENDA TECHNOLOGY CO.,LTD
Model Number	: T-60X Pro, T-60X, T-65X, T-65X Pro, T-68X, T-68X Pro, T-69X, T-69X Pro
Operate Frequency	: Bluetooth: 2.402GHz~2.480GHz
Antenna Designation	: Internal Antenna
Modulation	: Bluetooth: GFSK, pi/4-DQPSK, 8DPSK
Antenna Gain	: 1.71 dBi

Remark: T-60X Pro, T-60X, T-65X, T-65X Pro, T-68X, T-68X Pro, T-69X, T-69X Pro. Just different sales regions lead to different model number, all of the model's circuit theory, electrical design and the Critical Components are identical. Unless otherwise specified, the model T-60X Pro was chosen as the representative model to perform all the tests.

Bluetooth:

$$f=2402+k \text{ MHz (k=0,1,2...,78)}$$

3.2. Block Diagram of EUT Configuration

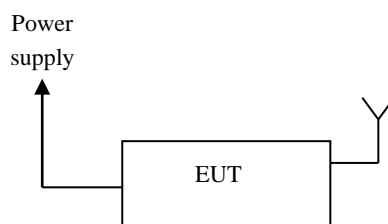

3.3. Test System Configuration

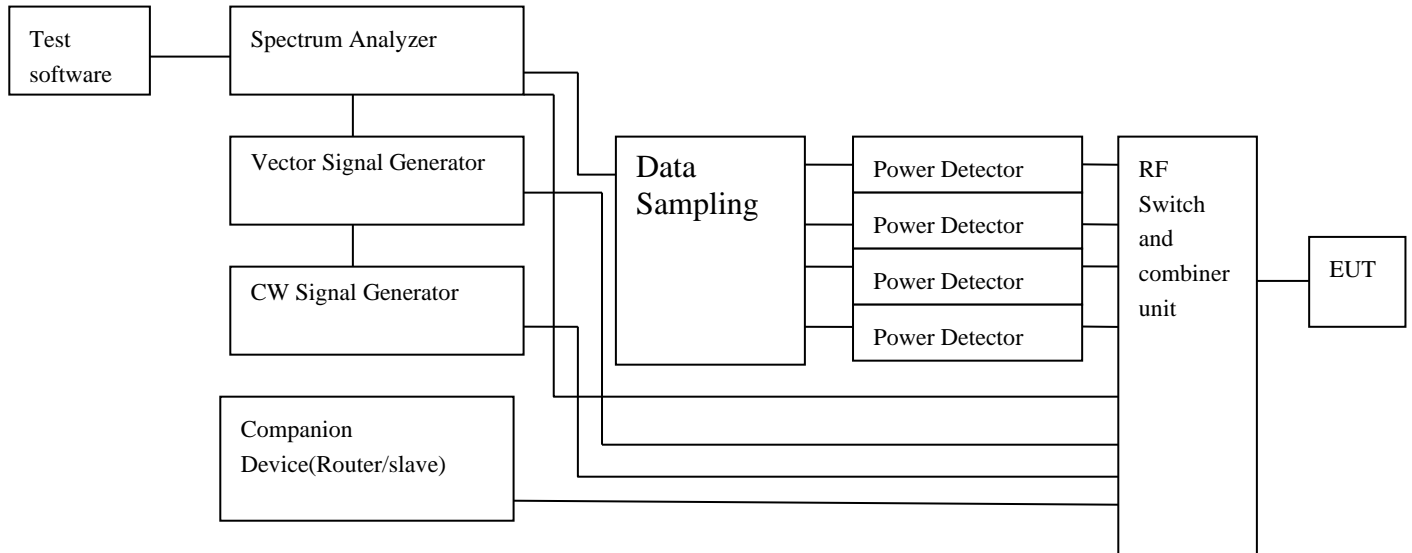

3.4. Operating Condition of EUT

- Test mode 1: Bluetooth(DH1) TX
- Test mode 2: Bluetooth(DH3) TX
- Test mode 3: Bluetooth(DH5) TX
- Test mode 4: Bluetooth(3-DH1) TX
- Test mode 5: Bluetooth(3-DH3) TX
- Test mode 6: Bluetooth(3-DH5) TX
- Test mode 7: Bluetooth(DH1) RX
- Test mode 8: Bluetooth(DH3) RX
- Test mode 9: Bluetooth(DH5) RX
- Test mode 10: Bluetooth(3-DH1) RX
- Test mode 11: Bluetooth(3-DH3) RX
- Test mode 12: Bluetooth(3-DH5) RX

Preliminary tests were performed in different data rate and the worst case is decided as below,

Bluetooth

Pre-scan was performed with DH1,DH3,DH5,3-DH1,3-DH3,3-DH5 .

3.5. Support Equipment List

Table 4 Support Equipment List

Name	Model No.	S/N	Manufacturer
Notebook	E460	SB12961	Lenovo



3.6. Test Conditions

Date of test : Jan.14, 2022 - Jan.17, 2022
 Date of EUT Receive : Jan.06, 2022
 Temperature: 0~45°C
 Relative Humidity:47%-50%
 NT =22°C -25°C
 HT =45 °C
 LT =0 °C
 NV = AC 230V/50Hz

Remark: “NT” means “Normal Temperature ”
 “LT” means “Low Temperature ”
 “HT” means “High Temperature ”
 “NV” means “Normal Voltage ”

3.7. Test Settings

Test Mode: Bluetooth Settings:

Setting	Value
Modulation	FHSS
Adaptive	Yes
Number Of Transmission Chains	1
Antenna Gain Port 1	1.71 dBi
Beamforming Gain	No
Nominal Channel Bandwidth	1 MHz
Attenuation / Pathloss File Port 1	DUT Cable_12.75Ghz_10dB
Spurious Tx Receiver reference level below power	20 dB
power measurement for radiated	No
DUT Port Occupied Channel Bandwidth	1
LBT Based	Yes
Short Signaling	Yes
CCA	18 us
DUT Port Adaptivity	1
Channel Occupation Time	13 ms
Minimum Number of Hopping Frequencies	20
Maximum Number of Hopping Frequencies	79
Number of active Hopping Frequencies	79
Number of Blacklisted Hopping Frequencies	0
Hopping Frequency Separation	1 MHz
Dwell Time	15 ms
Maximum Dwell Time	400 ms
DUT Port Dwell Time	1
Maximum final spurious measurements	3

3.8. Modifications

No modification was made.



4. TEST EQUIPMENT USED

Table 5 Test Equipment List

No.	Equipment	Model No.	Manufacturer	Calibrated until
Radio spectrum				
SB11873/01	Power sensor, Power Meter	OSP120+OSP-B157	R&S	2022-05-17
SB11873/02	Vector Signal Generator	SMBV100A	R&S	2022-05-16
SB3433	Signal Generator	SMT03	R&S	2022-05-16
SB11818	Temperature & Humidity Chamber	EH-010U	Espec,CHINA	2022-03-18
SB9060	SIGNAL ANALYZER	FSQ40	R&S	2022-05-16
SB3611	Regulated DC power supply	PDS36-10	KENWOOD	2022-03-15
SB13989	WIRELESS CONNECTIVITY TESTER	CMW270	R&S	2022-05-16
Radiated spurious emissions				
SB13956	EMI Test Receiver	ESR26	R&S	2022-02-04
SB13964	Trilog Broadband Antenna(30M-3GHz)	VULB9163	Schwarzbeck	2022-12-29
SB3435	Double-Ridged Waveguide Horn Antenna(1G~18GHz)	HF906	R&S	2022-12-02
---	Amplifier(1-18GHz)	---	R&S	---
SB8501/01	Double-Ridged Waveguide Horn Antenna(1G~18GHz)	HF907	R&S	2022-11-07
SB3955	Trilog Broadband Antenna(30M-3GHz)	VULB9163	Schwarzbeck	2022-12-29
SB9962	Fully Anechoic Chamber	7.7*4.0*3.4m	SAEMC	2023-01-02

Table 6 Test Software

Test Items	Test software		
	Software Name	Developers	Version
Radiated spurious emissions	EMC32	R&S	9.26.01
Radio spectrum	JS1120-3	Tonscend	V2.6.77.0518



5. RF OUTPUT POWER

5.1. Test Requirements

5.1.1. Test Standard

EN 300 328 V2.2.2 (2019-07)

5.1.2. Test Limit

For non-adaptive frequency hopping systems

The maximum RF output power for non-adaptive Frequency Hopping equipment, shall be declared by the supplier. The maximum RF output power for this equipment shall be equal to or less than the value declared by the supplier. This declared value shall be equal to or less than 20dBm.

The maximum RF output power for non-adaptive equipment shall be declared by the supplier and shall not exceed 20 dBm. For non-adaptive equipment using wide band modulations other than FHSS, the maximum RF output power shall be equal to or less than the value declared by the supplier.

For adaptive equipment using wide band modulations other than FHSS, the maximum RF output power shall be 20 dBm.

The maximum RF output power for non-adaptive equipment shall be declared by the manufacturer and shall not exceed 20 dBm. For non-adaptive equipment using wide band modulations other than FHSS, the maximum RF output power shall be equal to or less than the value declared by the manufacturer.

This limit shall apply for any combination of power level and intended antenna assembly.

5.2. Test Procedure

Refer to EN 300 328 V2.2.2 (2019-07) Clause 5.4.2

R&S®OSP120 module is used for power measurement, and it supports High sampling rate greater than 1 M sample/s and measurement time of up to 32 s at 1 M sample/s. Test software is used to control the power detector and the sampling unit. For adaptive equipment, the measurement duration shall be long enough to ensure a minimum number of bursts (at least 10) are captured.

5.3. Test Data

Please refer to the Annex A.



6. POWER SPECTRAL DENSITY

6.1. Test Requirements

6.1.1. Test Standard

EN 300 328 V2.2.2 (2019-07)

6.1.2. Test Limit

For equipment using wide band modulations other than FHSS, the maximum Power Spectral Density is limited to 10dBm per MHz.

6.2. Test Procedure

Refer to EN 300 328 V2.2.2 (2019-07) Clause 5.4.3

Test software is used to control the spectrum analyzer to use the following settings:

Start Frequency: 2 400 MHz

Stop Frequency: 2 483,5 MHz

Resolution BW: 10 kHz

Video BW: 30 kHz

Sweep Points: 15000

Detector: RMS Trace Mode: Max Hold Sweep time: 10s

Test software acquires the trace data and calculate the Spectral Density in 1MHz.

6.3. Test Data

N/A



7. ACCUMULATED TRANSMIT TIME, FREQUENCY OCCUPATION & HOPPING SEQUENCE

7.1. Test Requirements

7.1.1. Test Standard

EN 300 328 V2.2.2 (2019-07)

7.1.2. Test Limit

Non-adaptive FHSS equipment

The Accumulated Transmit Time on any hopping frequency shall not be greater than 15 ms within any observation period of 15 ms multiplied by the minimum number of hopping frequencies (N) that have to be used.

In order for the FHSS equipment to comply with the Frequency Occupation requirement, it shall meet either of the following two options:

Option 1: Each hopping frequency of the Hopping Sequence shall be occupied at least once within a period not exceeding four times the product of the dwell time and the number of hopping frequencies in use.

Option 2: The probability that each hopping frequency is occupied shall be between $((1 / U) \times 25 \%)$ and 77 % where U is the number of hopping frequencies in use. The Hopping Sequence(s) shall contain at least N hopping frequencies where N is either 5 or the result of 15 MHz divided by the minimum Hopping Frequency Separation in MHz, whichever is the greater.

NOTE: See also clause 4.3.1.5.3.1 for the Hopping Frequency Separation applicable to non-adaptive FHSS equipment.

Non-Adaptive FHSS equipment, may blacklist some but not all hopping frequencies. From the N hopping frequencies defined above, the equipment shall transmit on at least one hopping frequency. For the blacklisted frequencies, the equipment has to occupy these frequencies for the duration of the average dwell time (see also definition for blacklisted frequency in clause 3.1).

Adaptive FHSS equipment

Adaptive FHSS equipment shall be capable of operating over a minimum of 70 % of the band specified in 2400-2483.5MHz.

The Accumulated Transmit Time on any hopping frequency shall not be greater than 400 ms within any observation period of 400 ms multiplied by the minimum number of hopping frequencies (N) that have to be used.

In order for the FHSS equipment to comply with the Frequency Occupation requirement, it shall meet either of the following two options:

Option 1: Each hopping frequency of the Hopping Sequence shall be occupied at least once within a period not exceeding four times the product of the dwell time and the number of hopping frequencies in use.

Option 2: The occupation probability for each frequency shall be between $((1 / U) \times 25 \%)$ and 77 % where U is the number of hopping frequencies in use.

The Hopping Sequence(s) shall contain at least N hopping frequencies at all times, where N is either 15 or the result of 15 MHz divided by the minimum Hopping Frequency Separation in MHz, whichever is the greater.

NOTE: See also clause 4.3.1.5.3.2 for the Hopping Frequency Separation applicable to adaptive FHSS equipment.

For Adaptive FHSS equipment, from the N hopping frequencies defined above, the equipment shall consider at least one hopping frequency for its transmissions. Providing that there is no interference present on this hopping frequency with a level above the detection threshold defined in clause 4.3.1.7.2.2, point 5 or clause 4.3.1.7.3.2, point 5, then the equipment shall have transmissions on this hopping frequency. For Adaptive FHSS equipment using LBT, if a signal is detected during the CCA, the equipment may jump immediately to the next hopping frequency in the Hopping Sequence (see clause 4.3.1.7.2.2, point 2) provided the limit for Accumulated Transmit Time on the new hopping frequency is respected.

7.2. Test Procedure

Refer to EN 300 328 V2.2.2 (2019-07) Clause 5.4.4



7.3. Test Data

Please refer to the Annex A.



8. HOPPING FREQUENCY SEPARATION

8.1. Test Requirements

8.1.1. Test Standard

EN 300 328 V2.2.2 (2019-07)

8.1.2. Test Limit

For non-adaptive FHSS equipment, the Hopping Frequency Separation shall be equal to or greater than the Occupied Channel Bandwidth (see clause 4.3.1.8), with a minimum separation of 100 kHz.

For FHSS equipment with a maximum declared RF Output power level of less than 10 dBm e.i.r.p. or for non-adaptive FHSS equipment operating in a mode where the RF Output power is less than 10 dBm e.i.r.p., the Hopping Frequency Separation shall be equal to or greater than 100 kHz.

For adaptive FHSS equipment, the minimum Hopping Frequency Separation shall be 100 kHz.

Adaptive FHSS equipment that switched to a non-adaptive mode for one or more hopping frequencies because interference was detected on each of these hopping frequencies with a level above the threshold level defined in clause 4.3.1.7.2.2, point 5 or clause 4.3.1.7.3.2, point 5, does not have to comply with the Hopping Frequency Separation provided in clause 4.3.1.5.3.1 for non-adaptive FHSS equipment. If the Hopping Frequency Separation is below the Occupied Channel Bandwidth but greater than 100 kHz, the equipment is allowed to continue to operate with this Hopping Frequency Separation as long as the interference remains present on these hopping frequencies. As this relaxed Hopping Frequency Separation only applies to adaptive FHSS equipment, the FHSS equipment shall continue to operate in an adaptive mode on all other hopping frequencies.

Adaptive FHSS equipment which decided to operate in a non-adaptive mode on one or more hopping frequencies without the presence of interference, shall comply with the limit for Hopping Frequency Separation for non-adaptive FHSS equipment defined



in clause 4.3.1.5.3.1 (first paragraph) for these hopping frequencies.

8.2. Test Procedure

Refer to EN 300 328 V2.2.2 (2019-07) Clause 5.4.5

8.3. Test Data

Please refer to the Annex A.

9. ADAPTIVITY

9.1. Test Requirements

9.1.1. Test Standard

EN 300 328 V2.2.2 (2019-07)

9.1.2. Test Limit

Adaptive FHSS

Adaptive FHSS using LBT

- At the start of every dwell time, before transmission on a hopping frequency, the equipment shall perform a Clear Channel Assessment (CCA) check using energy detect. The CCA observation time shall be not less than 0,2 % of the Channel Occupancy Time with a minimum of 18 μ s.
- The Channel Occupancy Time for a given hopping frequency, which starts immediately after a successful CCA, shall be less than 60 ms followed by an Idle Period of minimum 5 % of the Channel Occupancy Time with a minimum of 100 μ s.
- The detection threshold shall be proportional to the transmit power of the transmitter: for a 20 dBm e.i.r.p. transmitter the detection threshold level (TL) shall be equal to or less than -70 dBm/MHz at the input to the receiver assuming a -0.76 dBi (receive) antenna assembly. This threshold level (TL) may be corrected for the (receive) antenna assembly gain (G); however, beamforming gain (Y) shall not be taken into account. For power levels less than 20 dBm e.i.r.p., the detection threshold level may be relaxed to:

$$TL = -70 \text{ dBm/MHz} + 10 \times \log_{10} (100 \text{ mW} / P_{\text{out}}) \quad (P_{\text{out}} \text{ in mW e.i.r.p.})$$

Table 7 Unwanted Signal parameters

Wanted signal mean power from companion device	Unwanted signal frequency (MHz)	Unwanted CW signal power (dBm)
sufficient to maintain the link (see note 2)	2 395 or 2 488,5 (see note 1)	-35 (see note 3)
NOTE 1: The highest frequency shall be used for testing operating channels within the range 2 400 MHz to 2 442 MHz, while the lowest frequency shall be used for testing operating channels within the range 2 442 MHz to 2 483,5 MHz. See clause 5.4.6.1.		
NOTE 2: A typical value which can be used in most cases is -50 dBm/MHz.		
NOTE 3: The level specified is the level at the UUT receiver input assuming a -0.76 dBi antenna assembly gain. In case of conducted measurements, this level has to be corrected for the (in-band) antenna assembly gain (G). In case of radiated measurements, this level is equivalent to a power flux density (PFD) in front of the UUT antenna.		

Adaptive FHSS using DAA

- The Channel Occupancy Time for a given hopping frequency shall be less than 40 ms. For equipment using a dwell time > 40 ms that wants to have other transmissions during the same hop (dwell time) an Idle Period (no transmissions) of minimum 5 % of the Channel Occupancy Period with a minimum of 100 µs shall be implemented.
- For FHSS equipment using DAA with a dwell time < 40 ms, the maximum Channel Occupancy Time may be non-contiguous, i.e. spread over a number of Hopping Sequences (equal to 40 ms divided by the dwell time [ms]).
- The detection threshold shall be proportional to the transmit power of the transmitter: for a 20 dBm e.i.r.p. transmitter the detection threshold level (TL) shall be equal to or less than -70 dBm/MHz at the input to the receiver assuming a -0.76 dBi (receive) antenna assembly. This threshold level (TL) may be corrected for the (receive) antenna assembly gain (G); however, beamforming gain (Y) shall not be taken into account. For power levels below 20 dBm e.i.r.p., the detection threshold level may be relaxed to:

$$TL = -70 \text{ dBm/MHz} + 10 \times \log_{10} (100 \text{ mW} / P_{\text{out}}) \quad (P_{\text{out}} \text{ in mW e.i.r.p.})$$

If implemented, Short Control Signalling Transmissions shall have a maximum TxOn / (TxOn + TxOff) ratio of 10 % within any observation period of 50 ms or within an observation period equal to the dwell time, whichever is less.

Table 8 Unwanted Signal parameters

Wanted signal mean power from companion device (dBm)	Unwanted signal frequency (MHz)	Unwanted CW signal power (dBm)
-30 (see note 2)	2 395 or 2 488,5 (see note 1)	-35 (see note 2)
<p>NOTE 1: The highest frequency shall be used for testing operating channels within the range 2 400 MHz to 2 442 MHz, while the lowest frequency shall be used for testing operating channels within the range 2 442 MHz to 2 483,5 MHz. See clause 5.4.6.1.</p> <p>NOTE 2: The level specified is the level at the UUT receiver input assuming a -0.76 dBi antenna assembly gain. In case of conducted measurements, this level has to be corrected for the (in-band) antenna assembly gain (G). In case of radiated measurements, this level is equivalent to a power flux density in front of the UUT antenna.</p>		

non-FHSS

Adaptive non-FHSS using DAA

- The Channel Occupancy Time shall be less than 40 ms. Each such transmission sequence shall be followed by an Idle Period (no transmissions) of minimum 5 % of the Channel Occupancy Time with a minimum of 100 µs.
- The detection threshold shall be proportional to the transmit power of the transmitter: for a 20 dBm e.i.r.p. transmitter the detection threshold level (TL) shall be equal to or less than -70 dBm/MHz at the input to the receiver assuming a -0.76 dBi (receive) antenna assembly. This threshold level (TL) may be corrected for the (receive) antenna assembly gain (G); however, beamforming gain (Y) shall not be taken into account. For power levels less than 20 dBm e.i.r.p., the detection threshold

level may be relaxed to:

$$TL = -70 \text{ dBm/MHz} + 10 \times \log_{10} (100 \text{ mW} / P_{\text{out}}) \quad (P_{\text{out}} \text{ in mW e.i.r.p.})$$

Table 9 Unwanted Signal parameters

Wanted signal mean power from companion device (dBm)	Unwanted signal frequency (MHz)	Unwanted CW signal power (dBm)
-30 (see note 2)	2 395 or 2 488,5 (see note 1)	-35 (see note 2)
<p>NOTE 1: The highest frequency shall be used for testing operating channels within the range 2 400 MHz to 2 442 MHz, while the lowest frequency shall be used for testing operating channels within the range 2 442 MHz to 2 483,5 MHz. See clause 5.4.6.1.</p> <p>NOTE 2: The level specified is the level at the UUT receiver input assuming a -0.76 dBi antenna assembly gain. In case of conducted measurements, this level has to be corrected for the (in-band) antenna assembly gain (G). In case of radiated measurements, this level is equivalent to a power flux density in front of the UUT antenna.</p>		

Adaptive non-FHSS using LBT(Frame Based Equipment)

- The equipment shall observe the operating channel for the duration of the CCA observation time which shall be not less than 18 μs.
- The Channel Occupancy Time shall be in the range 1 ms to 10 ms followed by an Idle Period of at least 5 % of the Channel Occupancy Time used in the equipment for the current Frame Period.
- The energy detection threshold for the CCA shall be proportional to the transmit power of the transmitter: for a 20 dBm e.i.r.p. transmitter the CCA threshold level (TL) shall be equal to or less than -70 dBm/MHz at the input to the receiver assuming a -0.76 dBi (receive) antenna assembly. This threshold level (TL) may be corrected for the (receive) antenna assembly gain (G); however, beamforming gain (Y) shall not be taken into account. For power levels less than 20 dBm e.i.r.p. the CCA threshold level may be relaxed to:

$$TL = -70 \text{ dBm/MHz} + 10 \times \log_{10} (100 \text{ mW} / P_{\text{out}}) \quad (P_{\text{out}} \text{ in mW e.i.r.p.})$$

Table 10 Unwanted Signal parameters

Wanted signal mean power from companion device (dBm)	Unwanted signal frequency (MHz)	Unwanted CW signal power (dBm)
sufficient to maintain the link (see note 2)	2 395 or 2 488,5 (see note 1)	-35 (see note 3)
<p>NOTE 1: The highest frequency shall be used for testing operating channels within the range 2 400 MHz to 2 442 MHz, while the lowest frequency shall be used for testing operating channels within the range 2 442 MHz to 2 483,5 MHz. See clause 5.4.6.1.</p> <p>NOTE 2: A typical conducted value which can be used in most cases is -50 dBm/MHz.</p> <p>NOTE 3: The level specified is the level at the UUT receiver input assuming a -0.76 dBi antenna assembly gain. In case of conducted measurements, this level has to be corrected for the (in-band) antenna assembly gain (G). In case of radiated measurements, this level is equivalent to a power flux density in front of the UUT antenna.</p>		

Adaptive non-FHSS using LBT(Load Based Equipment)

- The equipment shall observe the operating channel for the duration of the CCA observation time which shall be not less than 18 μs.
- The Channel Occupancy Time shall be less than 13 ms.
- The energy detection threshold for the CCA shall be proportional to the transmit power of the transmitter: for a 20 dBm e.i.r.p. transmitter the CCA threshold level (TL) shall be equal to or less than -70 dBm/MHz at the input to the receiver assuming a -0.76 dBi (receive) antenna assembly. This threshold level (TL) may be corrected for the (receive) antenna assembly gain (G); however, beamforming gain (Y) shall not be taken into account. For power levels less than 20 dBm e.i.r.p., the CCA threshold level may be relaxed to:

$$TL = -70 \text{ dBm/MHz} + 10 \times \log_{10} (100 \text{ mW} / P_{\text{out}}) \quad (P_{\text{out}} \text{ in mW e.i.r.p.})$$

Table 11 Unwanted Signal parameters

Wanted signal mean power from companion device (dBm)	Unwanted signal frequency (MHz)	Unwanted CW signal power (dBm)
sufficient to maintain the link (see note 2)	2 395 or 2 488,5 (see note 1)	-35 (see note 2)
NOTE 1: The highest frequency shall be used for testing operating channels within the range 2 400 MHz to 2 442 MHz, while the lowest frequency shall be used for testing operating channels within the range 2 442 MHz to 2 483,5 MHz. See clause 5.4.6.1.		
NOTE 2: A typical conducted value which can be used in most cases is -50 dBm/MHz.		
NOTE 3: The level specified is the level at the UUT receiver input assuming a -0.76 dBi antenna assembly gain. In case of conducted measurements, this level has to be corrected for the (in-band) antenna assembly gain (G). In case of radiated measurements, this level is equivalent to a power flux density (PFD) in front of the UUT antenna.		

If implemented, Short Control Signalling Transmissions of adaptive non-FHSS equipment shall have a maximum TxOn / (TxOn + TxOff) ratio of 10 % within any observation period of 50 ms.

NOTE: Duty Cycle is defined in clause 4.3.2.4.2.

9.2. Test Procedure

Refer to EN 300 328 V2.2.2 (2019-07) Clause 5.4.6

9.3. Test Data

N/A



10. OCCUPIED CHANNEL BANDWIDTH

10.1. Test Requirements

10.1.1. Test Standard

EN 300 328 V2.2.2 (2019-07)

10.1.2. Test Limit

The Occupied Channel Bandwidth shall be within the band 2.4GHz to 2.4835GHz.

For non-adaptive FHSS equipment with e.i.r.p. greater than 10 dBm, the Occupied Channel Bandwidth for every occupied hopping frequency shall be equal to or less than 5 MHz.

For non-adaptive non-FHSS equipment with e.i.r.p. greater than 10 dBm, the Occupied Channel Bandwidth shall be equal to or less than 20 MHz.

10.2. Test Procedure

Refer to EN 300 328 V2.2.2 (2019-07) Clause 5.4.7

Connect the UUT to the spectrum analyser and use the following settings:

Centre Frequency: The centre frequency of the channel under test

RBW: 500KHz(HT 20), 20KHz(Bluetooth), 50KHz(Bluetooth(LE))

VBW: 2MHz(HT 20), 100KHz(Bluetooth), 200KHz(Bluetooth(LE))

Frequency Span: $2 \times$ Nominal Channel Bandwidth

Detector Mode: RMS

Trace Mode: Max Hold

Sweep time: 1s

10.3. Test Data

Please refer to the Annex A.

11. TRANSMITTER UNWANTED EMISSIONS IN THE OUT-OF-BAND DOMAIN

11.1. Test Requirements

11.1.1. Test Standard

EN 300 328 V2.2.2 (2019-07)

11.1.2. Test Limit

The transmitter unwanted emissions in the out-of-band domain but outside the allocated band, shall not exceed the values provided by the mask in figure 3.

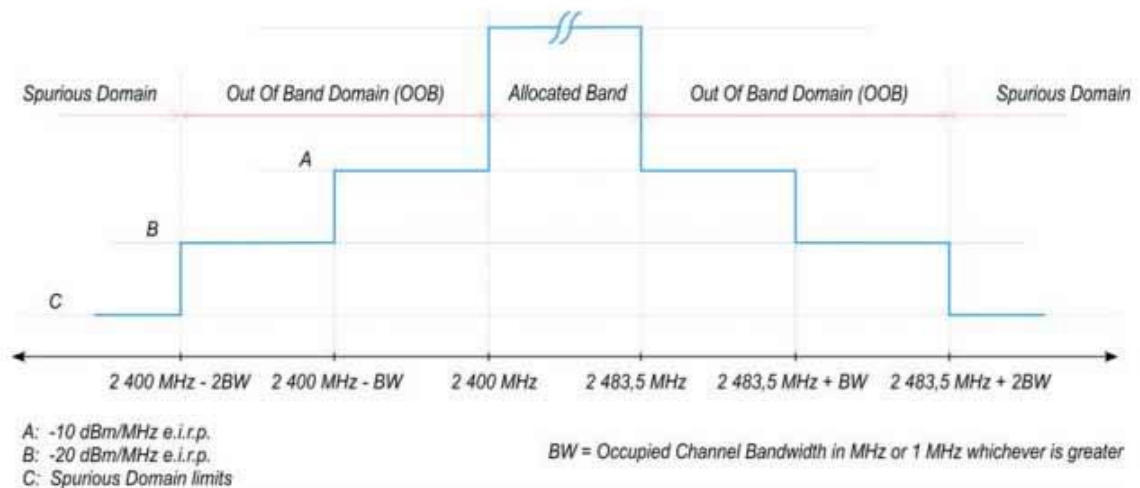

Figure 3: Transmit mask

11.2. Test Procedure

Refer to EN 300 328 V2.2.2 (2019-07) Clause 5.4.8

11.3. Test Data

Please refer to the Annex A.

12. SPURIOUS EMISSIONS

12.1. Test Requirements

12.1.1. Test Standard

EN 300 328 V2.2.2 (2019-07)

12.1.2. Test Limit

Table 12 Transmitter limits for spurious emissions

Transmitter Limits for Spurious Emissions		
Frequency Range	Maximum power E.R.P. (\leq 1GHz) E.I.R.P. ($>$ 1GHz)	Bandwidth
30 MHz to 47 MHz	-36 dBm	100 kHz
47 MHz to 74 MHz	-54 dBm	100 kHz
74 MHz to 87,5 MHz	-36 dBm	100 kHz
87,5 MHz to 118 MHz	-54 dBm	100 kHz
118 MHz to 174 MHz	-36 dBm	100 kHz
174 MHz to 230 MHz	-54 dBm	100 kHz
230 MHz to 470 MHz	-36 dBm	100 kHz
470 MHz to 694 MHz	-54 dBm	100 kHz
694 MHz to 1 GHz	-36 dBm	100 kHz
1 GHz to 12,75 GHz	-30 dBm	1 MHz

Table 13 Spurious emission limits for receivers

Frequency range	Limit	Bandwidth
30 MHz to 1 GHz	-57 dBm	100 kHz
above 1 GHz to 12,75 GHz	-47 dBm	1 MHz

12.2. Test Procedure

Refer to EN 300 328 V2.2.2 (2019-07) Clause 5.4.9

12.3. Test Data

Please refer to the Annex A and Annex B.

13. RECEIVER BLOCKING

13.1. Test Requirements

13.1.1. Test Standard

EN 300 328 V2.2.2 (2019-07)

13.1.2. Test Limit

Table 14 Receiver Blocking parameters for Receiver Category 1 equipment

Wanted signal mean power from companion device (dBm) (see notes 1 and 4)	Blocking signal frequency (MHz)	Blocking signal power (dBm) (see note 4)	Type of blocking signal
(-133 dBm + 10 × log 10 (OCBW)) or -68 dBm whichever is less (see note 2)	2 380	-34	CW
	2 504		
(-139 dBm + 10 × log 10 (OCBW)) or -74 dBm whichever is less (see note 3)	2 300		
	2 330		
	2 524		

NOTE 1: OCBW is in Hz.

NOTE 2: In case of radiated measurements using a companion device and the level of the wanted signal from the companion device cannot be determined, a relative test may be performed using a wanted signal up to $P_{min} + 26$ dB where P_{min} is the minimum level of wanted signal required to meet the minimum performance criteria as defined in clause 4.3.1.12.3 in the absence of any blocking signal.

NOTE 3: In case of radiated measurements using a companion device and the level of the wanted signal from the companion device cannot be determined, a relative test may be performed using a wanted signal up to $P_{min} + 20$ dB where P_{min} is the minimum level of wanted signal required to meet the minimum performance criteria as defined in clause 4.3.1.12.3 in the absence of any blocking signal.

NOTE 4: The level specified is the level at the UUT receiver input assuming a -0.76 dBi antenna assembly gain. In case of conducted measurements, this level has to be corrected for the (in-band) antenna assembly gain (G). In case of radiated measurements, this level is equivalent to a power flux density (PFD) in front of the UUT antenna with the UUT being configured/positioned as recorded in clause 5.4.3.2.2.

Table 15 Receiver Blocking parameters receiver category 2 equipment

Wanted signal mean power from companion device (dBm) (see notes 1 and 3)	Blocking signal frequency (MHz)	Blocking signal power (dBm) (see note 3)	Type of blocking signal
$(-139 \text{ dBm} + 10 \times \log 10 \text{ (OCBW)} + 10 \text{ dB})$ or $(-74 \text{ dBm} + 10 \text{ dB})$ whichever is less (see note 2)	2 380 2 504 2 300 2 584	-34	CW

NOTE 1: OCBW is in Hz.

NOTE 2: In case of radiated measurements using a companion device and the level of the wanted signal from the companion device cannot be determined, a relative test may be performed using a wanted signal up to $P_{\text{min}} + 26 \text{ dB}$ where P_{min} is the minimum level of wanted signal required to meet the minimum performance criteria as defined in clause 4.3.1.12.3 in the absence of any blocking signal.

NOTE 3: The level specified is the level at the UUT receiver input assuming a -0.76 dBi antenna assembly gain. In case of conducted measurements, this level has to be corrected for the (in-band) antenna assembly gain (G). In case of radiated measurements, this level is equivalent to a power flux density (PFD) in front of the UUT antenna with the UUT being configured/positioned as recorded in clause 5.4.3.2.2.

Table 16 Receiver Blocking parameters receiver category 3 equipment

Wanted signal mean power from companion device (dBm) (see notes 1 and 3)	Blocking signal frequency (MHz)	Blocking signal power (dBm) (see note 3)	Type of blocking signal
(-139 dBm + 10 × log 10 (OCBW) + 20 dB) or (-74 dBm + 20 dB) whichever is less (see note 2)	2 380 2 504 2 300 2 584	-34	CW
<p>NOTE 1: OCBW is in Hz.</p> <p>NOTE 2: In case of radiated measurements using a companion device and the level of the wanted signal from the companion device cannot be determined, a relative test may be performed using a wanted signal up to P min + 30 dB where P min is the minimum level of wanted signal required to meet the minimum performance criteria as defined in clause 4.3.1.12.3 in the absence of any blocking signal.</p> <p>NOTE 3: The level specified is the level at the UUT receiver input assuming a -0.76 dBi antenna assembly gain. In case of conducted measurements, this level has to be corrected for the (in-band) antenna assembly gain (G). In case of radiated measurements, this level is equivalent to a power flux density (PFD) in front of the UUT antenna with the UUT being configured/positioned as recorded in clause 5.4.3.2.2.</p>			

13.2. Test Procedure

Refer to EN 300 328 V2.2.2 (2019-07) Clause 5.4.11

13.3. Test Data

Please refer to the Annex A.



ANNEX A TEST DATA(CONDUCTED TEST DATA)

Appendix A: RF Output Power

Test Condition	TestMode	Antenna	Channel	EIRP[dBm]	Limit[dBm]	Verdict
NTNV	DH1	Ant1	Hop	3.40	20	PASS
	3DH1	Ant1	Hop	2.40	20	PASS
LTVN	DH1	Ant1	Hop	3.22	20	PASS
	3DH1	Ant1	Hop	2.44	20	PASS
HTNV	DH1	Ant1	Hop	3.28	20	PASS
	3DH1	Ant1	Hop	2.07	20	PASS



Appendix C: Accumulated Transmit Time, Frequency Occupation and Hopping Sequence

Test Result

Accumulated Transmit Time

TestMode	Antenna	Channel	Result [ms]	Limit[ms]	Verdict
DH5	Ant1	Hop_2402	304.404	400	PASS
		Hop_2480	305.457	400	PASS
3DH5	Ant1	Hop_2402	308.617	400	PASS
		Hop_2480	305.457	400	PASS

Frequency Occupation

TestMode	Antenna	Channel	Result [Num.]	Limit [Num.]	Verdict
DH5	Ant1	Hop_2402	3	1	PASS
		Hop_2480	3	1	PASS
3DH5	Ant1	Hop_2402	3	1	PASS
		Hop_2480	3	1	PASS

Hopping Sequence

TestMode	Antenna	Channel	Hop. [Num.]	Limit[Num.]	Band Use [%]	Limit [%]	Verdict
DH5	Ant1	Hop	79	15	95.95	70	PASS
3DH5	Ant1	Hop	79	15	96.29	70	PASS



Appendix D: Hopping Frequency Separation

Test Result

Test Mode	Antenna	Channel	Result [MHz]	Limit[MHz]	Verdict
DH1	Ant1	Hop	1	0.100	PASS
3-DH1	Ant1	Hop	1.003	0.100	PASS



Appendix E: Occupied Channel Bandwidth

Test Result

Test Mode	Antenna	Channel	OCB[MHz]	FL[MHz]	FH[MHz]	Limit[MHz]	Verdict
DH1	Ant1	2402	0.934	2401.4960	2402.4300	2400 to 2483.5	PASS
		2480	0.932	2479.4940	2480.4260	2400 to 2483.5	PASS
3-DH1	Ant1	2402	1.158	2401.3900	2402.5480	2400 to 2483.5	PASS
		2480	1.162	2479.3860	2480.5480	2400 to 2483.5	PASS



Appendix F: Transmitter Unwanted Emissions In The Out-Of-Band Domain

Test Result

Test Mode	Antenna	Channel	Verdict
DH1	Ant1	Hop	PASS
3-DH1	Ant1	Hop	PASS

Test Graphs

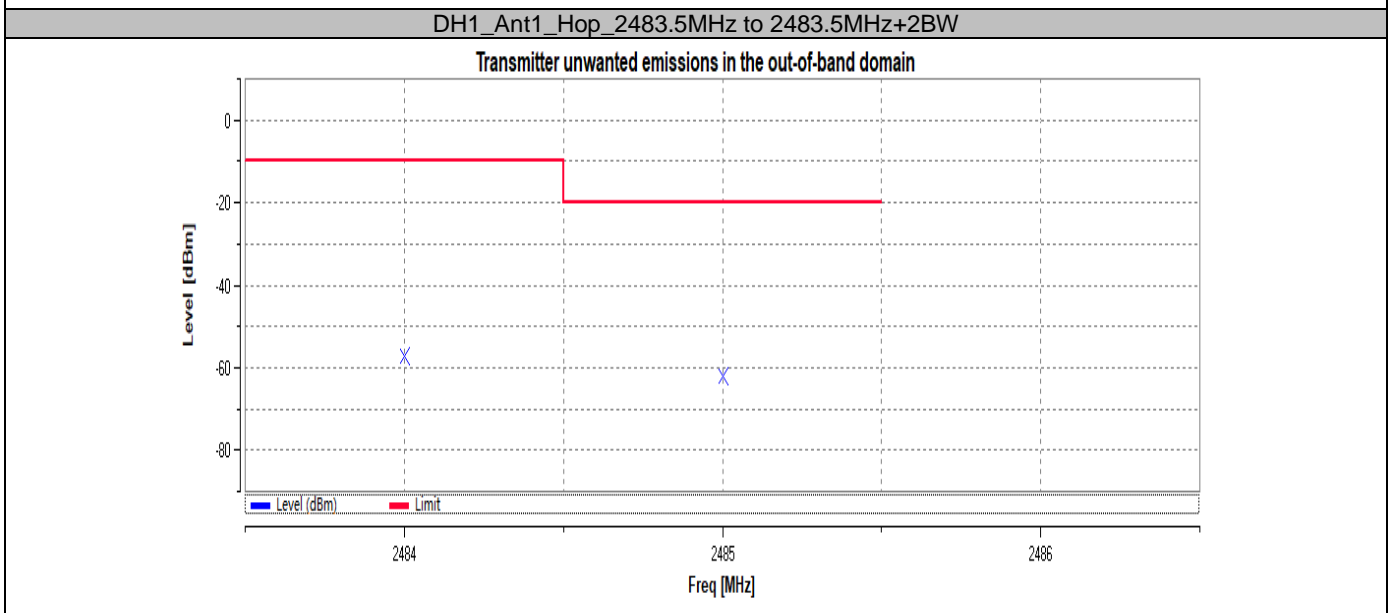
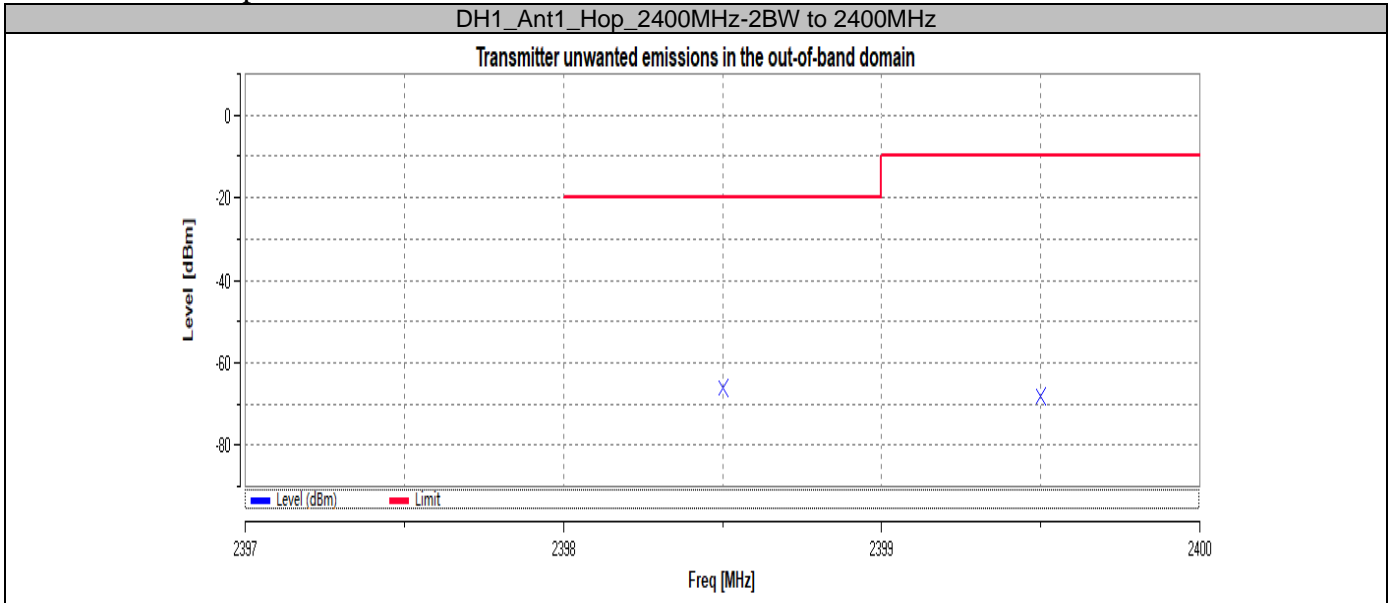

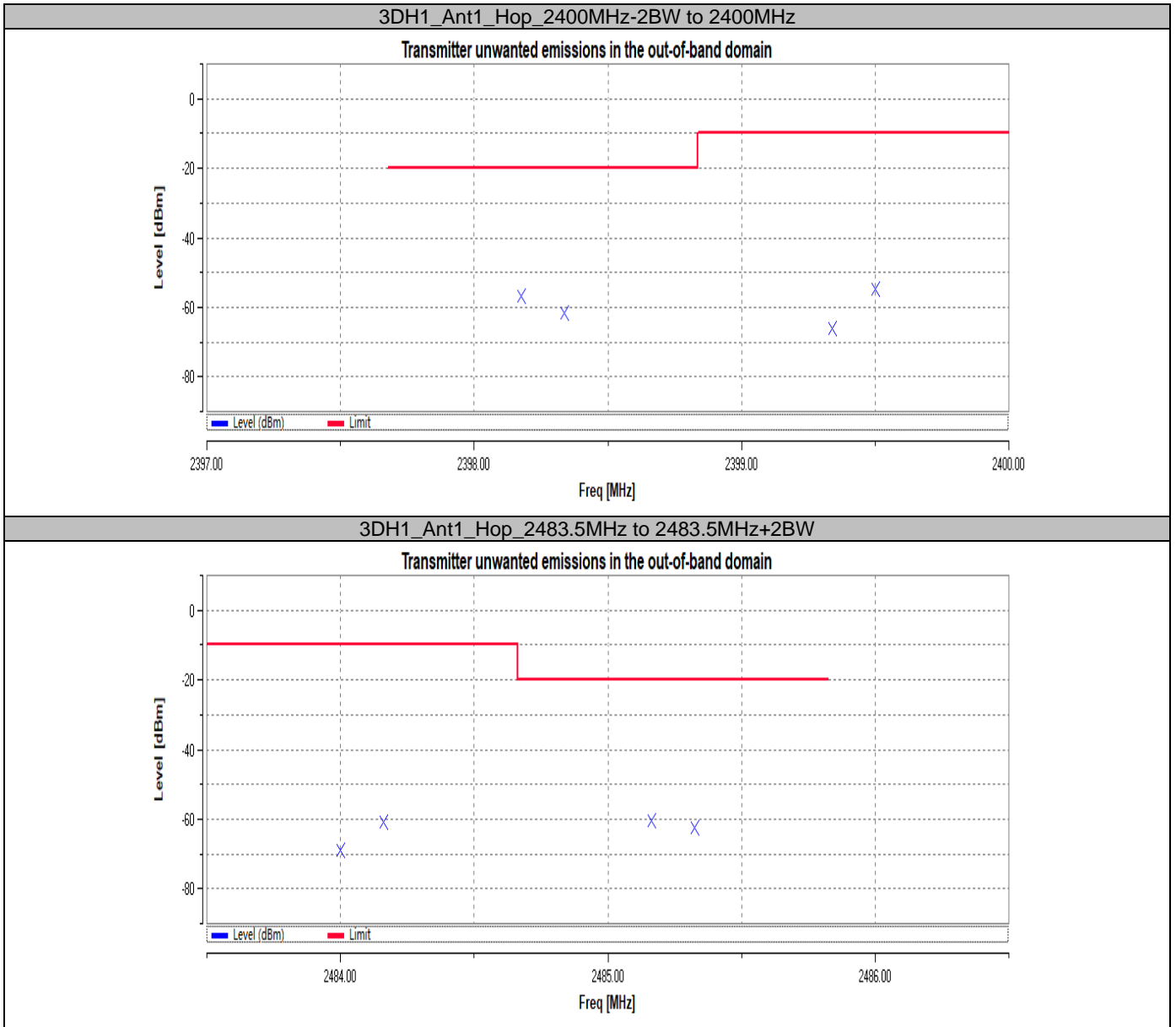



Appendix G: Transmitter unwanted emissions in the spurious domain

Test Result-Pre-scan

TestMode	Antenna	Channel	Freq. [MHz]	Level[dBm]	Limit[dBm]	Verdict
DH1	Ant1	2402	---	---	---	PASS
		2480	---	---	---	PASS

Test Graphs-Pre-scan

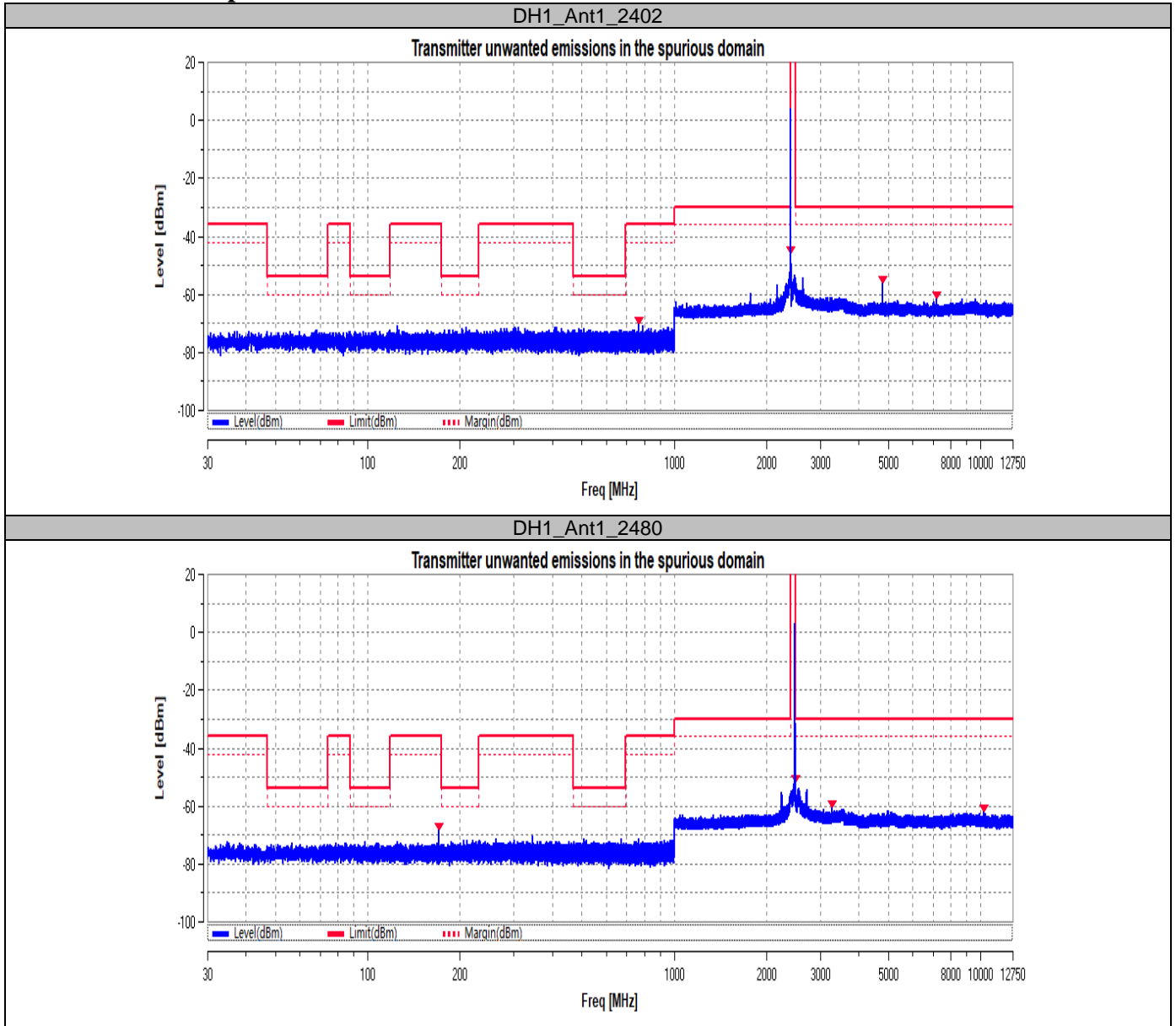



Appendix H: Receiver spurious emissions

Test Result-Pre-scan

Test Mode	Antenna	Channel	Freq. [MHz]	Level[dBm]	Limit[dBm]	Verdict
DH1	Ant1	2402	---	---	---	PASS
			---	---	---	PASS
		2480	---	---	---	PASS
			---	---	---	PASS

Test Result- Emissions identified during the pre-scan

/

Test Graphs Test Graphs-Pre-scan

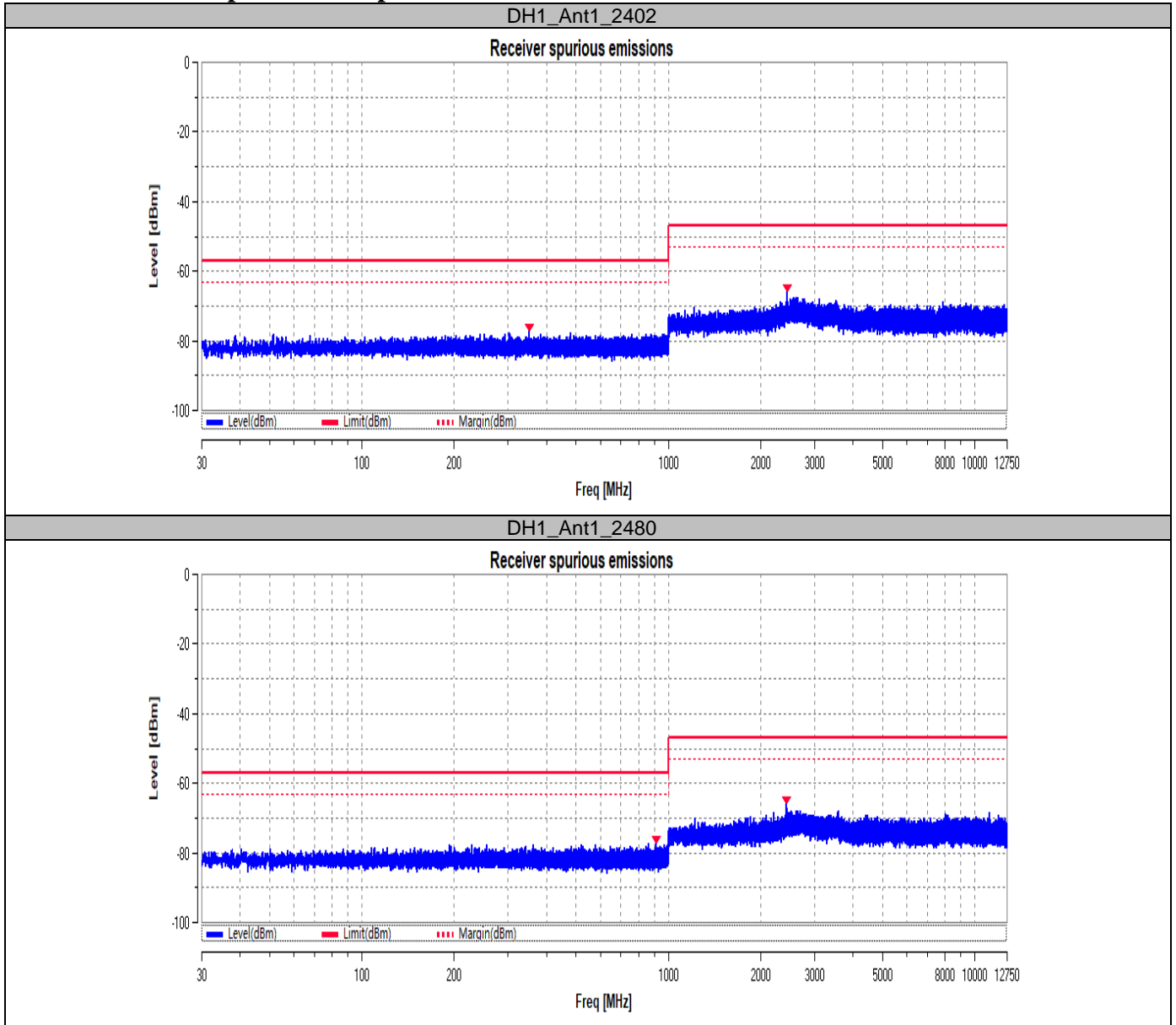

Test Graphs- Emissions identified during the pre-scan

/



Appendix I: Receiver Blocking

Test Result

TestMode	Antenna	Channel	Pmin [dBm]	Wanted signal [dBm]	Freq. [MHz]	CW [dBm]	PER [%]	Limit [%]	Verdict
DH1	Ant1	Hop	---	-67.46	2300	-32.16	0.20	≤10	PASS
			---	-67.46	2380	-32.16	0.10	≤10	PASS
			---	-67.46	2504	-32.16	0.20	≤10	PASS
			---	-67.46	2584	-32.16	0.40	≤10	PASS

ANNEX B RADIATED MEASUREMENT TEST DATA

Test Graphs

DH1_2402_Horizontal

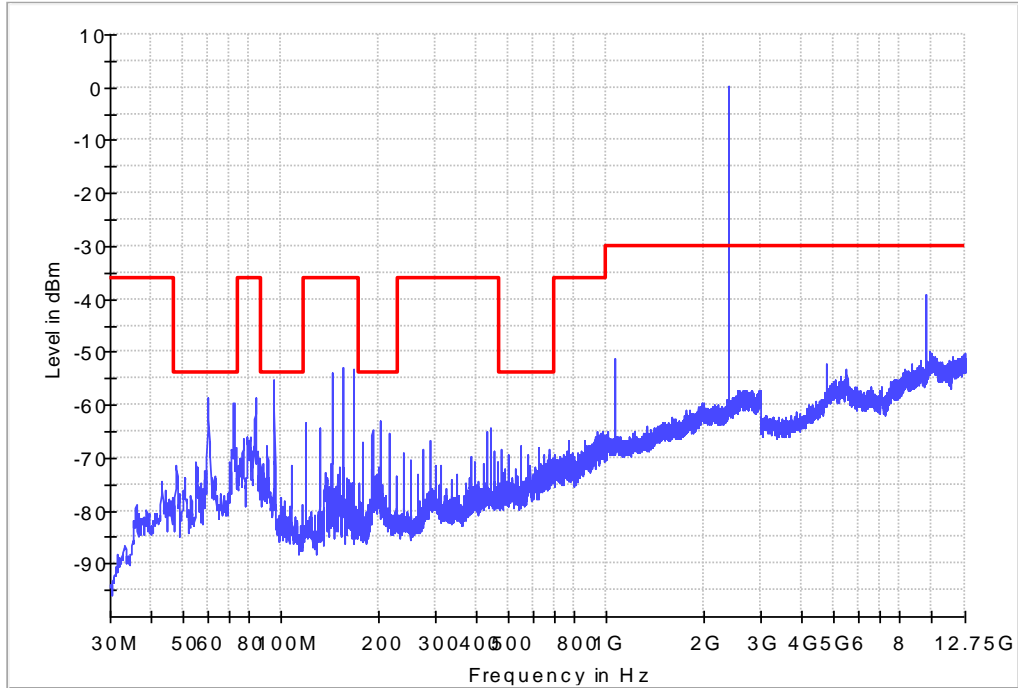

DH1_2402_Vertical

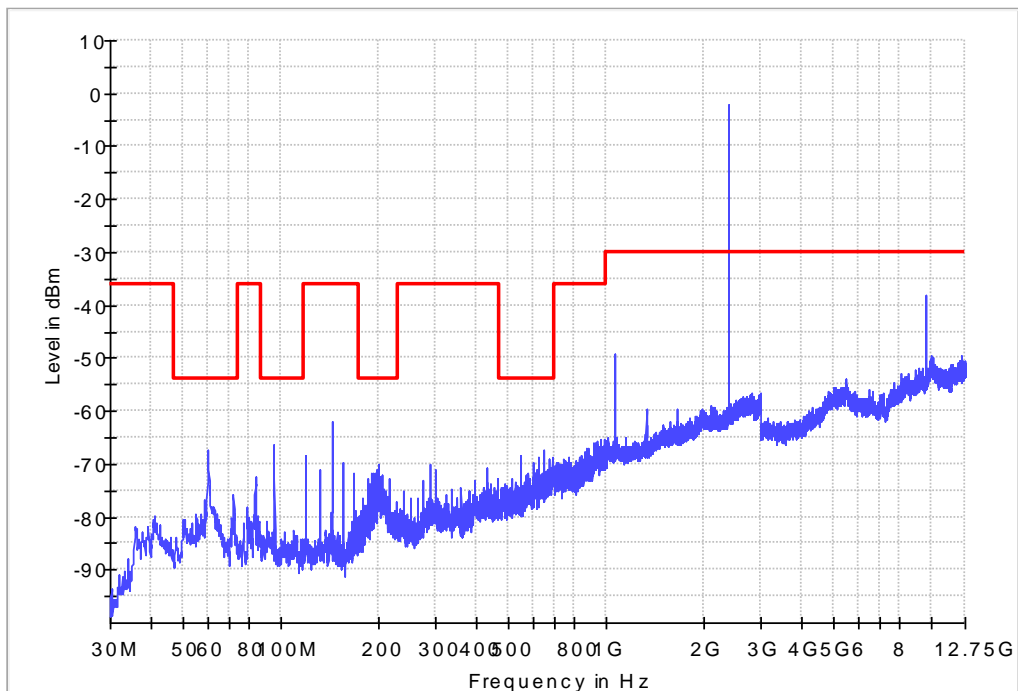

Table 17 Transmitter Spurious Emission Test Data



Test mode: 1/2480MHz				
Frequency MHz	Readings dBm	Limits dBm	Polarization	note
---	---	---	Horizontal	---
---	---	---	Vertical	---

Notes: The data was shown the worst case DH1.



Test Graphs

BLE_2480_Horizontal

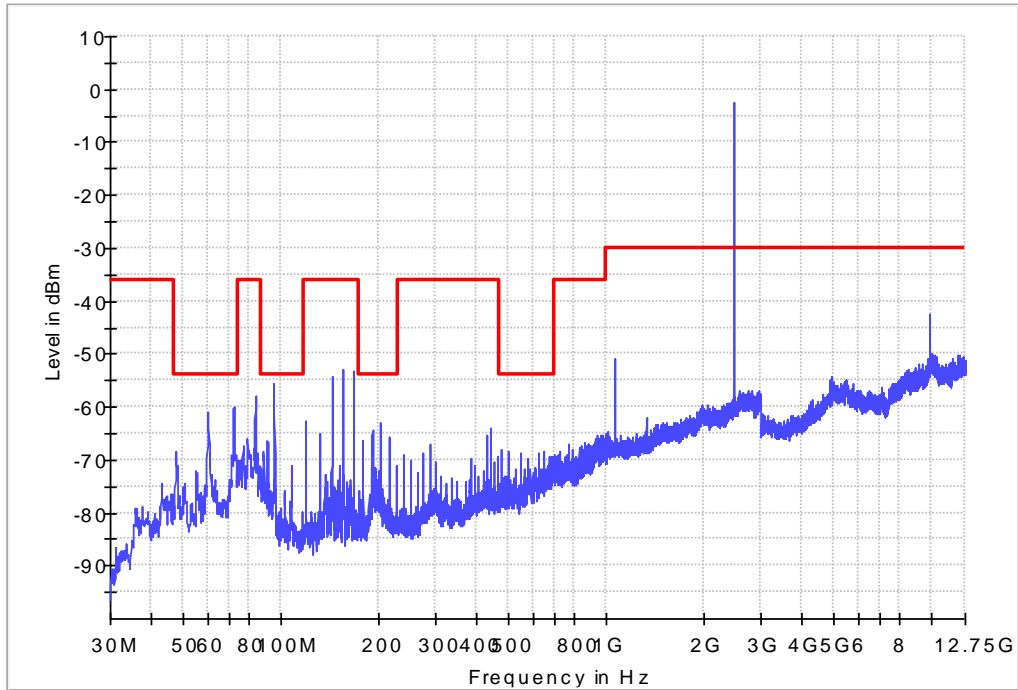

BLE_2480_Vertical

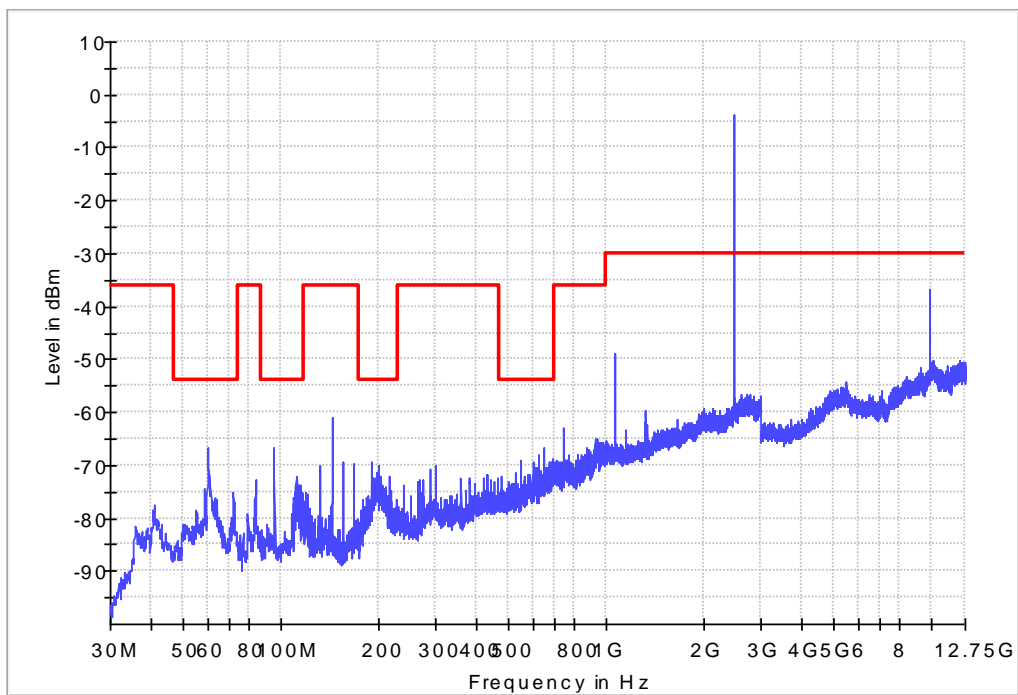



Appendix B: Receiver spurious emissions

Table 18 Receiver Spurious Emission Test Data

Test mode: 7/2402MHz				
Frequency MHz	Readings dBm	Limits dBm	Polarization	note
---	---	---	Horizontal	---
---	---	---	Vertical	---

Notes: The data was shown the worst case DH1.



Test Graphs

DH1_2402_Horizontal

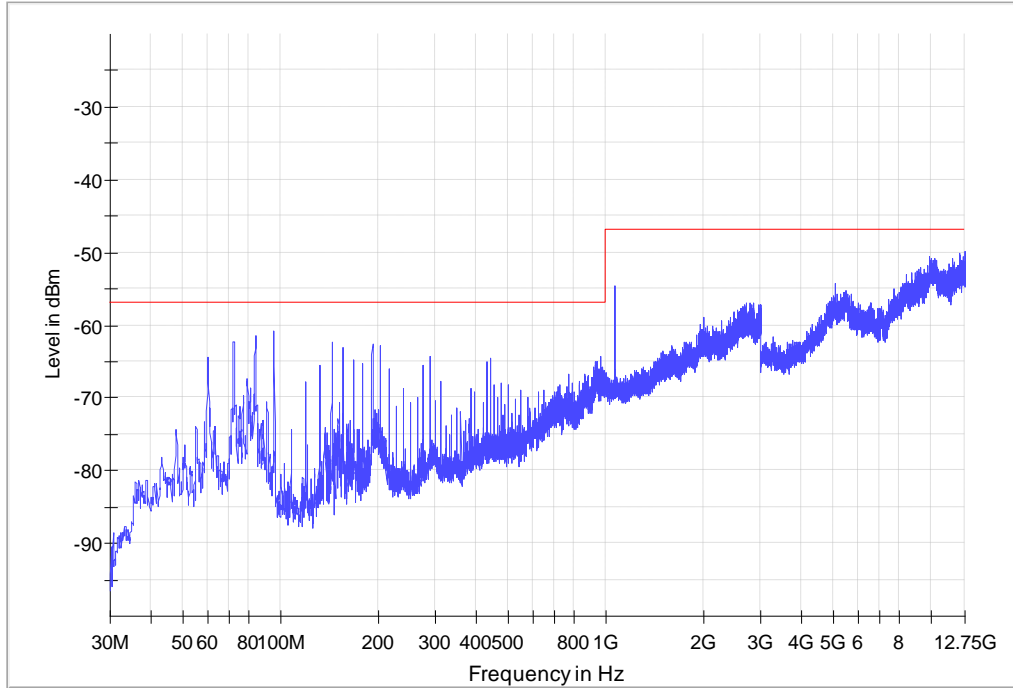

DH1_2402_Vertical

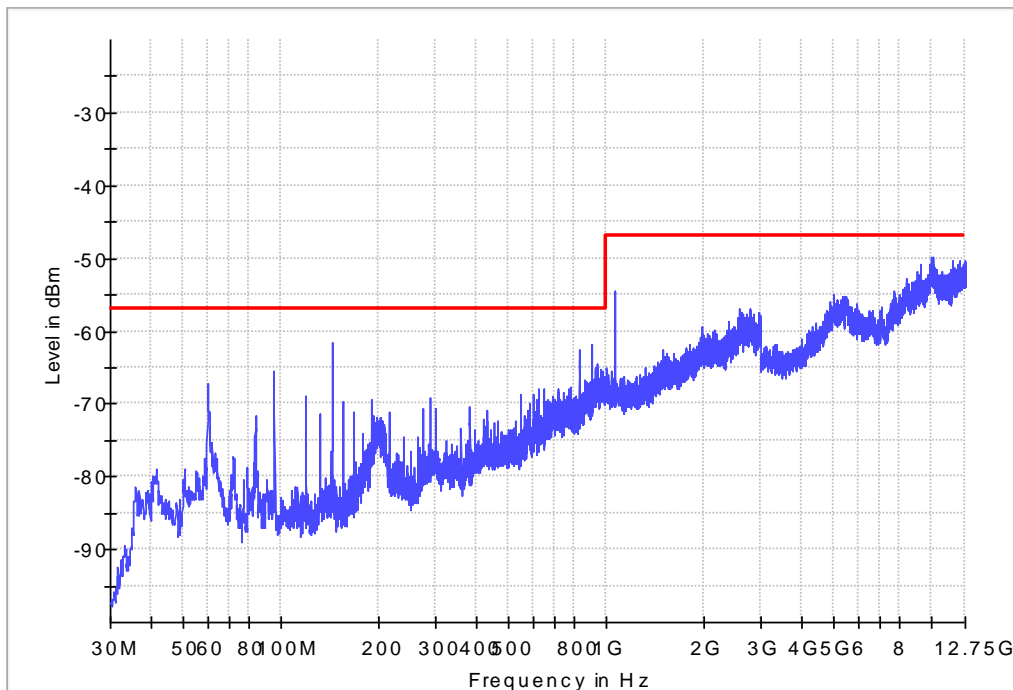



Table 19 Receiver Spurious Emission Test Data

Test mode: 7/2480MHz				
Frequency MHz	Readings dBm	Limits dBm	Polarization	note
---	---	---	Horizontal	---
---	---	---	Vertical	---

Notes: The data was shown the worst case DH1.



Test Graphs

DH1_2480_Horizontal

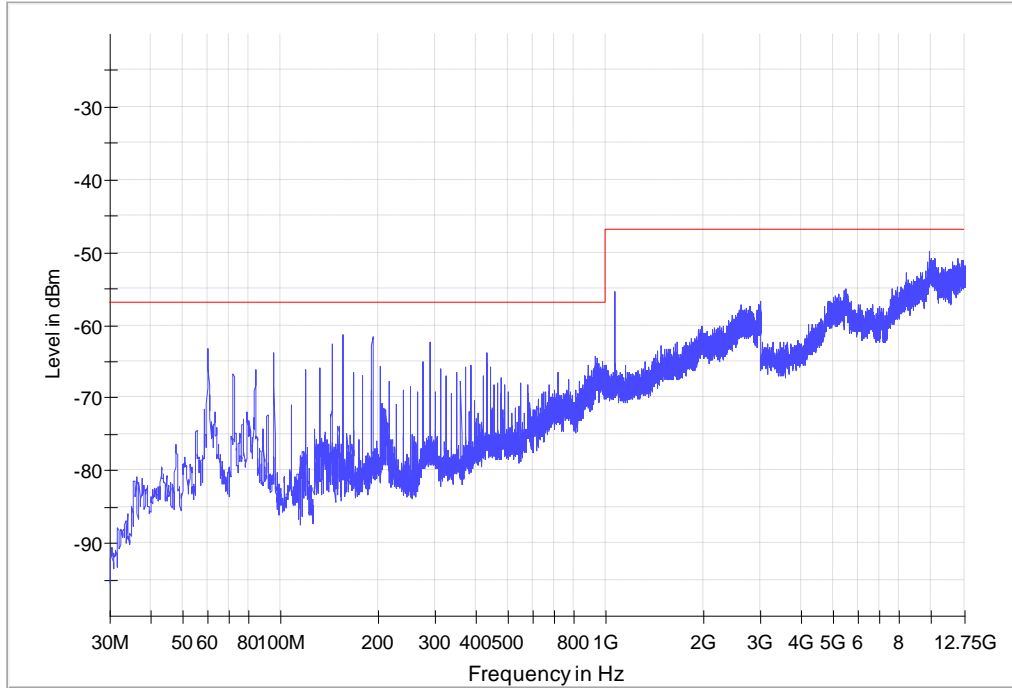

DH1_2480_Vertical

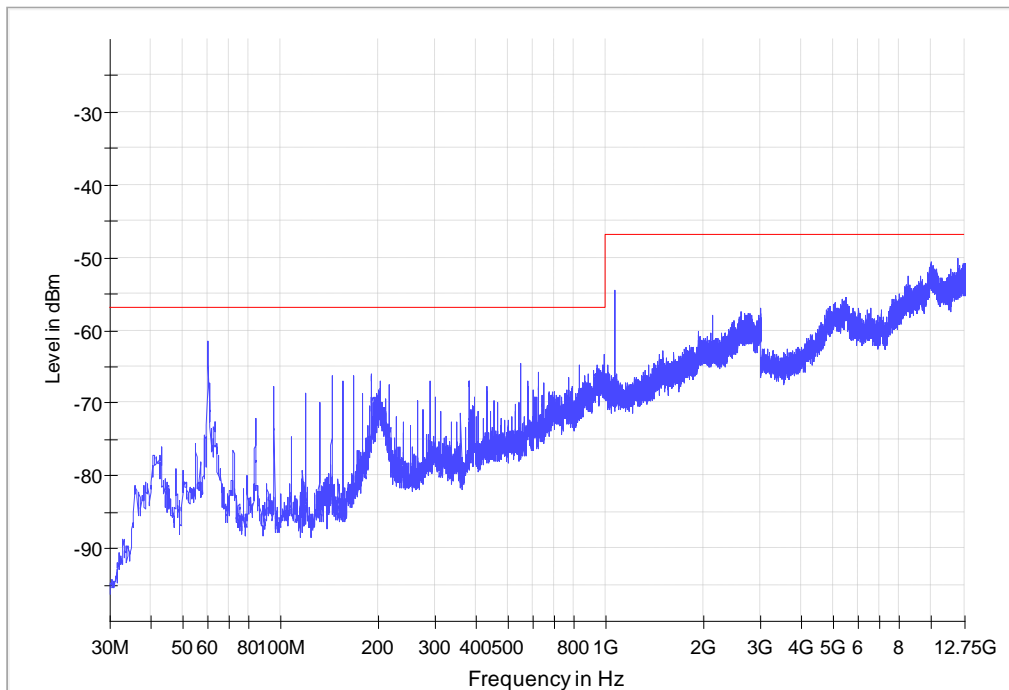

ANNEX C TEST SETUP PHOTOS

Setup for Radio Spectrum Testing



Radiated spurious emissions Test



END OF REPORT